

PORTABLE SOLAR STREET LAMP

ARIFFIN BIN ABDULLAH

This thesis is submitted as partial fulfillment of the requirement for the award of the
Bachelor Degree Electrical Engineering (Power System)

Faculty of Electrical & Electronic Engineering
Universiti Malaysia Pahang

NOVEMBER, 2008

ABSTRACT

This system is designed for outdoor application in un-electrified remote rural areas. This system is an ideal application for campus and village street lighting. The system is provided with battery storage backup sufficient to operate the light for 10-11 hours daily. The project is about to develop and fabricate the circuit that can charge the lead acid battery during day time by using solar as the source. To control the circuit for charging, I have used the circuit charging that can implement the condition of the charging whether it's in charging condition or in float condition. When charging condition, red LED will turn on until the battery reach the full charge state that is in floating condition and green LED will turn on. For the switching, I used PIC16F877A to switch on the lamp, by using the photocell sensor. The PIC16F877A will determine whether it is daytime or night time. The light will automatically on when the photocell sensor give the input to the PIC and PIC will give the output to the relay to switch on the light. To control the intensity of the light, we need the other input from the sensor. When sensor detect, PIC will give the output to switch on for the second light. So the intensity of the light will increase and the timing will start counter. After finish the counter, PIC will automatically of the second light. By using this method, its can save the energy that we using from the battery. When night change to the day, photocell sensor detect the ray from the sun, PIC will give the output to off the lamp and the charging circuit will continue charge the battery for the day.

TABLE OF CONTENT

CHAPTER	CONTENT	PAGE
	TITLE	i
	DECLARATION	ii
	DEDICATION	iii
	ACKNOWLEDGEMENT	iv
	ABSTRACT	v
	ABSTRAK	vi
	TABLE OF CONTENTS	vii
	LIST OF TABLE	xi
	LIST OF FIGURE	xii
	LIST OF ABBREVIATIONS	xiii
	LIST OF APPENDICES	xiv

TABLE OF CONTENTS

1	INTRODUCTION	
	1.0	Introduction 1
	1.1	Project Overview 1
	1.2	Project Aim 2
	1.3	Objective 2
	1.4	Scope of Project 3
2	LITERATURE REVIEW	
	2.0	Introduction 4
	2.1	Word History Solar Energy 4
	2.2	Word History Street Lamp 5
	2.3	Solar Energy 7
	2.4	Battery Charger 9
3	METHODOLOGY	
	3.0	Introduction 10
	3.1	Hardware Configuration 11
	3.1.1	Circuit Diagram 11
	3.1.2	Charging Circuit 12
	3.1.3	Charging Operation 13
	3.1.3.1	Schottky Rectifier 15

3.1.4	Control Circuit	17
3.1.4.1	PIC16F877A	18
3.1.4.2	Photocell Sensor	20
3.1.4.3	Wave Sensor	21
3.1.4.4	Relays	22
3.1.4.5	12V Lead Acid Battery	23
3.2	Software Configuration	24
3.2.1	Software Programming	24

4 RESULT AND ANALYSIS

4.0	Introduction	25
4.1	Estimation Time	26
4.2	Calculation	27
4.2.1	Charging	27
4.2.2	Discharging	28
4.3	Graph of Charging	29
4.4	Graph of Discharging	30
4.5	Cost of the Project	31
4.6	Commercializes	32

5 CONCLUSION AND RECOMMENDATIONS

5.0	Project Problem and Solution	33
5.1	Future recommendations	34
5.2	Conclusion	35

REFERENCE	36
APPENDIX A	37
APPENDIX B	38
APPENDIX C	40
APPENDIX D	41

CHAPTER 1

INTRODUCTION

1.0 Introduction

This chapter describes about the project's introduction. It consists of overview of the project, the project aim, objectives and scopes of the project.

1.1 Project Overview

This project is about to develop and fabricate the circuit that can charge the lead acid battery when in day by using solar as the source. To control the circuit of the charging, I used the circuit charging that can implement the condition of the charging whether its in charging condition of in float condition. When charging condition, red LED will turn on until the battery reach the full charge that is in floating condition, when floating, green LED will turn on. For the switching to the load, I used PIC16F877A to switch on the lamp, by using the photocell sensor and relay 5V, the PIC16F877A will determine whether is in daylight or in night by determination of ADC in that come from the photocell sensor. The value to determine the intensity of the light we had set up it into the coding of the PIC.

When PIC gets the input from ADC, PIC gives the output to the relay to switch on the light. To control the intensity of the light, we need the other input from the sensor

that is wave sensor. When wave sensor detect that have some wave from the user of the road, PIC will give the output to switch on for the second light. So the intensity of the light will increase and the timing will start counter. After finish the counter, PIC will automatically switch off the second light. By using this method, its can save the energy that we using from the battery. When night change to day, photocell sensor detect the ray from the sun, PIC will give the output to switch off the lamp and the charging circuit will continue charge the battery for the day.

1.2 Project Aim

The solar street lamp is designed specifically for portable use at the rural areas and energy backup if disaster happens. It's also as the new way to save the energy and use it more efficiently.

1.3 Objective

The main objective of this project is to develop the portable solar street lamp with the DC voltage as the source. There are two secondary objectives to be achieved in order to achieve the main objective stated above. The two secondary objectives were discussed in the following paragraph.

The first objective is to develop the charging circuit that can charge 12V lead acid battery by using the solar panel as the DC source. This charging circuit can implement the charging condition as we know we have several charging condition like charging condition and floating condition.

The second objective is to design and program the control circuit by that contain of PIC16F877A to control the circuit to switch on and off the lamp when the situation change like from the day to night. This circuit also to control the intensity of the light

that can improve the efficiency of using the DC energy that only use when need.(e.g. when nobody use the road, this portable solar street lamp just switch on with the low intensity of the lamp that's can save the energy and when its detect that have the user, this solar street lamp will switch on the high intensity lamp to beam the place for the users)

1.4 Scope Of The Project

The scope of the project includes construct the circuit in order to charge the 12V lead acid battery. The acid battery will supply power to switch the lamp when there is no light or night condition. Integration between sensor and wave sensor was also concentrated in development of this system. In order to control the circuit for switching the PIC16F877A was developed. Finally, the system was combined together to complete the development of the system

CHAPTER 2

LITERATURE REVIEW

2.0 Introduction

In this chapter, explanations about all the word history and literature review. The total figure related to this project will be added in this chapter along with the details.

Word History

2.1 Solar energy

Solar energy is the light and radiant heat from the Sun that influences Earth's climate and weather and sustains life. Solar power is sometimes used as a synonym for solar energy or more specifically to refer to electricity generated from solar radiation. Solar radiation is secondary resources like as wind and wave power, hydroelectricity and biomass account for most of the available flow of renewable energy on Earth.

Solar energy technologies can provide electrical generation by heat engine or photovoltaic means, space heating and cooling in active and passive solar buildings; potable water via distillation and disinfection, day lighting, hot water, thermal energy for cooking, and high temperature process heat for industrial purposes.

Solar energy refers primarily to the use of solar radiation for practical ends. All other renewable energies other than geothermal derive their energy from energy received from the sun.

Solar technologies are broadly characterized as either passive or active depending on the way they capture, convert and distribute sunlight. Active solar techniques use photovoltaic panels, pumps, and fans to convert sunlight into useful outputs. Passive solar techniques include selecting materials with favorable thermal properties, designing spaces that naturally circulate air, and referencing the position of a building to the Sun. Active solar technologies increase the supply of energy and are considered supply side technologies, while passive solar technologies reduce the need for alternate resources and are generally considered demand side technologies.

2.2 Street Lamp

Before we have incandescent lamps, gas lighting was in use in cities. The earliest of such street lamps were built in the Arab Empire, especially in Cordoba, Spain. The first electric street lighting employed arc lamps, initially the 'Electric candle', 'Jablohoff candle' or 'Yablochkov candle' developed by the Russian Pavel Yablochkov in 1875. This was a carbon arc lamp employing alternating current, which ensured that the electrodes burnt down at the same rate. Yablochkov candles were first used to light the Grands Magasins du Louvre, Paris where 80 were deployed. Soon after, experimental arrays of arc lamps were used to light Holborn Viaduct and the Thames Embankment in London - the first electric street lighting in Britain. More than 4,000 were in use by 1881, though by then an improved differential arc lamp had been developed by Friederich von Hefner-Alteneck of Siemens & Halske.

Arc lights had two major disadvantages. First, they emit an intense and harsh light which, although useful at industrial sites like dockyards, was discomforting in ordinary city streets. Second, they are maintenance-intensive, as carbon electrodes burn away swiftly. With the development of cheap, reliable and bright incandescent light bulbs at the end of the 19th century, they passed out of use for street lighting, but remained in industrial use longer.

Incandescent lamps used for street lighting until the advent of high-intensity discharge lamps, were often operated as high-voltage series circuits. Today, street lighting commonly uses high-intensity discharge lamps, often HPS high pressure sodium lamps. Such lamps provide the greatest amount of photo illumination for the least consumption of electricity. However when photo light calculations are used, it can be see how wrong HPS lamps are for night lighting. White light sources have been shown to double driver peripheral vision and increase driver brake reaction time at least 25%. When S/P light calculations are used, HPS lamp performance needs to be reduced by a minimum value of 75%. This is now a standard design criteria for the roads.



Figure 2.0: Old, new style and solar street lamp

2.3 SOLAR ENERGY

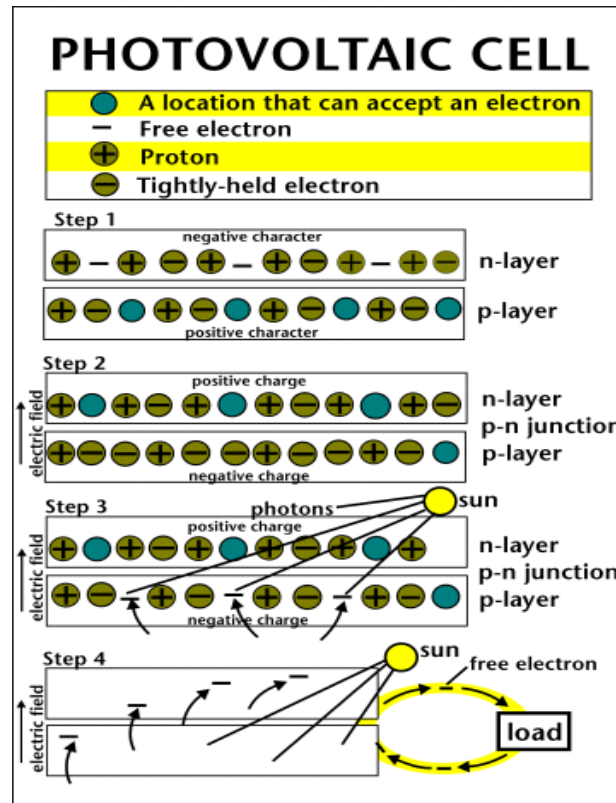

Figure 2.1 Photovoltaic Cell

Photovoltaic energy is the conversion of sunlight into electricity. A photovoltaic cell, commonly called a solar cell or PV, is the technology used to convert solar energy directly into electrical power. [1]

Sunlight is composed of photons, or particles of solar energy. These photons contain various amounts of energy corresponding to the different wavelengths of the solar spectrum. When photons strike a photovoltaic cell, they may be reflected, pass right through, or be absorbed. Only the absorbed photons provide energy to generate electricity.

When enough sunlight energy is absorbed by the material that is a semiconductor, electrons are come out from the material's atoms. Special treatment of the material surface during manufacturing makes the front surface of the cell more receptive to free electrons, so the electrons naturally migrate to the surface.

When the electrons leave their position, holes are formed. When many electrons, each carrying a negative charge, travel toward the front surface of the cell, the resulting imbalance of charge between the cell's front and back surfaces creates a voltage potential like the negative and positive terminals of a battery.

When the two surfaces are connected through an external load, electricity flows.

Photovoltaic cells, like batteries, generate direct current (DC)_which is generally used for small loads like electronic equipment. When DC from photovoltaic cells is used for commercial applications or sold to electric utilities using the electric grid, it must be converted to alternating current (AC) using inverters.

Advantages of photovoltaic systems are:

- Conversion from sunlight to electricity is direct, so that bulky mechanical generator systems are unnecessary.
- PV arrays can be installed quickly and in any size required or allowed.
- The environmental impact is minimal, requiring no water for system cooling and generating no by-products.

2.4 BATTERY CHARGER

A battery charger is a device used to put energy into a secondary cell or rechargeable battery by forcing an electric current through it.[2]

The charge current depends upon the technology and capacity of the battery being charged. For example, the current that should be applied to recharge a 12 V car battery will be very different from the current for a mobile phone battery.

A simple charger works by connecting a constant DC power source to the battery being charged. The simple charger does not modify its output based on time or the charge on the battery. This simplicity means that a simple charger is inexpensive, but there is a tradeoff in quality. Typically, a simple charger takes longer to charge a battery to prevent severe over-charging. Even so, a battery left in a simple charger for too long will be weakened or destroyed due to over-charging. These chargers can supply either a constant voltage or a constant current to the battery.

[1] - Energy Information Administration, *Electric Power Annual*, Form EIA-860, Annual Electric Generator Report database, 2006

[2] - http://en.wikipedia.org/wiki/Battery_charger

CHAPTER 3

METHODOLOGY

3.0 INTRODUCTION

In this chapter, explanations about all the circuit that were done for this project will be told. This chapter will be divided to hardware configuration and software configuration since this project will be used both hardware and software. All the calculation also will be state into this chapter. The total figure related to this project will be added in this chapter along with the details.

3.1 HARDWARE CONFIGURATION

3.1.1 CIRCUIT DIAGRAM

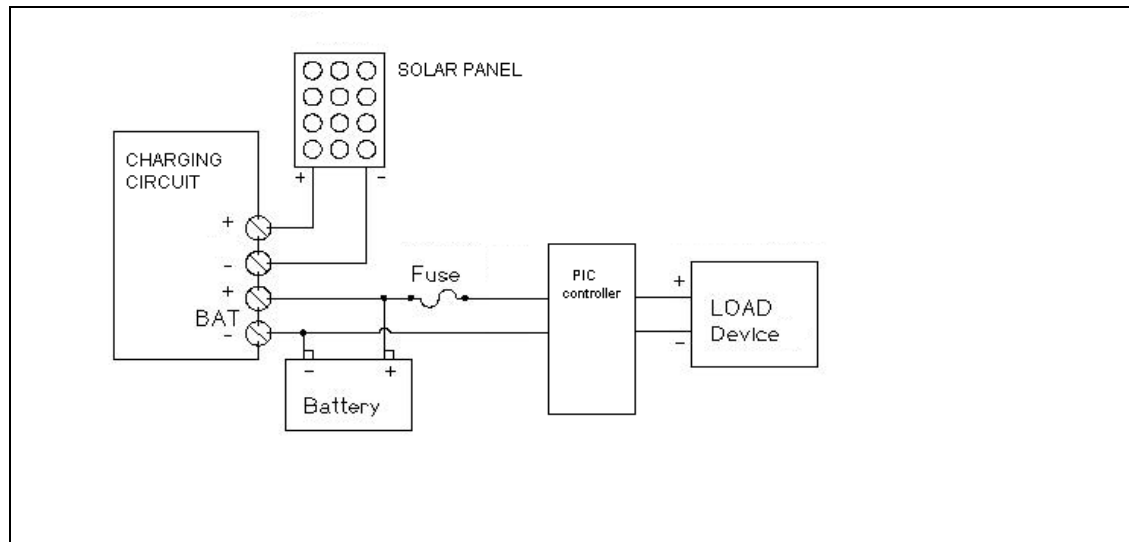

Figure 3.0: Block Diagram of Solar Street Lamp

This block diagram above is about the combination of the charging circuit and controller circuit to the load and the DC voltage source. At the day, solar panel will get the energy from the sun and the circuit charging will control the charging rate to the battery. The charging circuit will control the charging until the battery reaches the floating condition that is the full condition of the battery. The charging only occur when in the day because the solar need for the light to transfer the sunray to the electricity. When in the night condition the circuit charging automatically stop the charging and diode 20L15T are use to eliminate from current draw from the battery to the solar panel when in night condition. The features of the diode show below.

The circuit PIC controller will control the using of the energy of the battery to the load. This circuit controller is consisting of PIC16F877A, photocell sensor, wave sensor drivers. To control the switching of the load it's depend on the sensor

that will give the input to the PIC, PIC will give the output to the relays the same as the coding we had make. For this circuit, the photocell sensor will determine whether the situation is needed to switch on the lamp or not. So we should have the reference value. Some analysis I have made to choice the suitable value as a reference. The more detail about the photocell sensor will show below.

The control circuit also controls the intensity of the light beam. If there have user use the road, the PIC will switch on the high intensity of the light to light the place. This switching mode will trigger for the period that I had set that is about 10s. After 10s the PIC will switch on the low intensity of the light. By using this method, we can save the power of the battery. To detected whether that have or user of the road or not, I use wave sensor. The wave sensor will give the direction to the PIC to switch the suitable intensity of the lamp. The detail about the wave sensor will show below.

3.1.2 CHARGING CIRCUIT

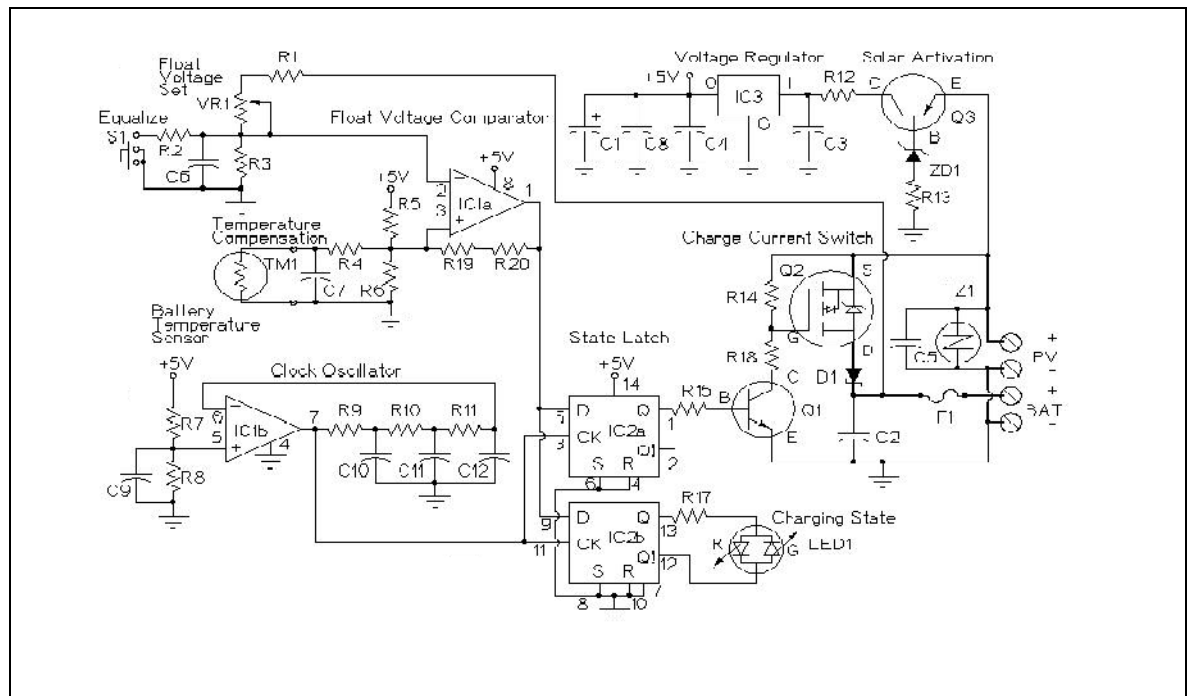

Figure 3.1: Charging Circuit

The above circuit is a solar charge controller; its function is to regulate the power flowing from a photovoltaic panel into a rechargeable battery. It features easy setup with one potentiometer for the float voltage adjustment, an equalize function for periodic overcharging, and automatic temperature compensation for better battery charging over a wide range of temperatures. This circuit is able to handle reverse polarity connection of both the battery and photovoltaic panel.

The design goals of this circuit were efficiency, simplicity, reliability and the use of field replaceable parts. A medium power solar system can be built with this circuit charging, a 12V solar panel that is rated from 100 milliamps to 20 amps and a lead acid or other rechargeable battery that is rated from 500 milliamp hours to 400 amp hours of capacity.

It is important to match the solar panel's current rating to the battery's amp-hour rating. A typical maximum battery charging current is $C/20$, so a 100 amp hour battery should have a solar panel rating of no greater than 5 amps. It is advisable to check the battery manufacturer's data sheets to find the maximum charge current. On the other hand, if the solar panel output current is too low, the battery may take too long to charge.

3.1.3 Charging Operation

The power control circuit can operate current from the solar panel input through Q3 and IC3. When the solar panel voltage exceeds 12V, zener diode ZD1 conducts and turns on Q3, providing power to IC3. IC3 produces a regulated 5 Volt power source. The 5V is used to power the circuit's logic and as a reference voltage for comparing to the battery float voltage.

The float voltage comparator IC1a compares the battery voltage (divided by R1/VR1 and R3) to a reference voltage (divided by R5 and R6). The comparison point is offset by the thermistor TM1 for temperature compensation. The comparison point is also modified by the Equalize switch, S1 and R2. The output of IC1a goes high (+5V) when the battery voltage is below the float voltage setting. The output goes low when the battery voltage is above the float voltage setting. This provides the charge/idle signal that controls the rest of the circuit.

The charge/idle signal is sent to IC2a and b, a pair of D-type flip-flops. The flip-flops are clocked by the IC1b phase-shift clock oscillator. The clocking causes the flip-flop output to produce a square wave charge/idle signal that is synchronized with the frequency of the clock oscillator. The two halves of IC2 operate in synchronization, IC2a is used to drive the current switching circuitry, IC2b is used to drive the charging state indicator LED either red (charging) or green (floating).

The clocked charge/idle signal switches bipolar transistor Q1 on and off. The Q1 signal is used to switch power MOSFET Q2, which switches the solar current on and off through the battery. The solar charging current flows through the heavy lines on the schematic. Diode D1 prevents the battery from discharging through the solar panel at night. Fuse F1 prevents excessive battery current from flowing in the event of a short circuit. Transzorb TZ1 absorbs transient voltage spikes that may be caused by lightning.

3.1.3.1 SCHOTTKY RECTIFIER (DIODE 20L15TS)

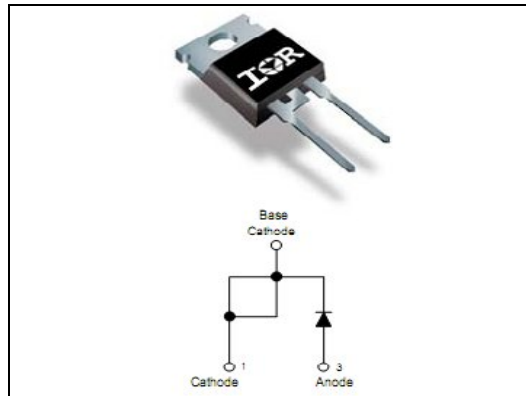

Figure 3.2: Schottky Diode

The Schottky rectifier module has been optimized for ultra low forward voltage drop specifically for the OR-ing of parallel power supplies. The proprietary barrier technology allows for reliable operation up to 125 °C junction temperature.

Typical applications are in parallel switching power supplies, converters, reverse battery protection, and redundant power subsystems.

- 125°C TJ
- operation ($V_R < 5V$)
- Single diode configuration
- Optimized for OR-ing applications
- Ultra low forward voltage drop
- Guard ring for enhanced ruggedness and long term reliability

- High purity, high temperature epoxy encapsulation for enhanced mechanical strength and moisture resistance

3.1 Shottky Diode Characteristics

Characteristics	Values	Units
$I_{F(AV)}$ Rectangular waveform	20	A
V_{RRM}	15	V
I_{FSM} @tp = 5 μ s sine	700	A
V_F @19 Apk, $T_J=125^\circ\text{C}$ (Typical)	0.25	V
T_J range	-55 to 125	$^\circ\text{C}$

3.1.3.1 PIC16F877A

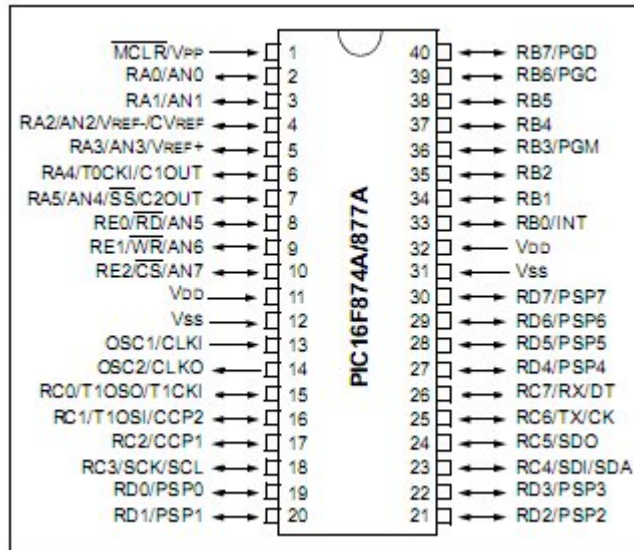

Figure 3.4: PIC16F877A

PIC is a family of Harvard architecture microcontrollers made by Microchip Technology, derived from the PIC1640 originally developed by General Instrument's Microelectronics Division. The name PIC initially referred to "Programmable Interface Controller", but shortly thereafter was renamed "Programmable Intelligent Computer". PIC are popular with developers and hobbyists alike due to their low cost, wide availability, large user base, extensive collection of application notes, availability of low cost or free development tools, and serial programming (and re-programming with flash memory) capability .

PIC16F785 is a small piece of semiconductor integrated circuits. The package type of these integrated circuits is DIP package. DIP stand for Dual Inline Package for semiconductor IC. This package is very easy to be soldered onto the strip board. However using a DIP socket is much easier so that this chip can be plugged and