

Development of Auto Car Jack Using Internal Car Power

M.M.Noor, K.Kadirgama, M.M.Rahman, M.S.M.Sani, M.R.M.Rejab

Faculty of Mechanical Engineering, Universiti Malaysia Pahang (UMP)

Tun Abdul Razak Highway, 26300 Gambang, Kuantan Pahang

Phone: +609-5492223 Fax: +609-5492244.

(muhamad@ump.edu.my / kumaran@ump.edu.my)

Abstract Car jacks usually use mechanical advantage to allow a human to lift a vehicle by manual force. More powerful jacks are using hydraulic power to provide more lift over greater distances. This paper presents the development of the car jack for emergency use with using internal cigarette lighter power (12volts). The automatic easy car-jack utilizes this power source to save individuals having to exert any energy. To increase the lifting power in order to ensure the power is adequate, gear ratio was used. The car jacker was developed utilizing the Solidworks® and its analyses to check the safety factor and force acting. The fabrication work has been done with milling and grinding machine. The car jacker will be tested and it predicted to have enough power to lift and holding the car as normal car jacker.

Keywords: Automatic car jack, cigarette lighter, Solidworks, gear ratio

INTRODUCTION

An automotive jack is a device used to raise all or part of a vehicle into the air in order to facilitate vehicle maintenances or breakdown repairs. Most people are familiar with the basic car jack (manually operated) and it's included as standard equipment for most of the new cars. Vehicle owners who would like to rotate their tires themselves either front to back and so forth or who may install snow tires before the winter and remove them in the spring need to use a jack to perform the job [1]. Changing a flat tire is not a very pleasant experience. Nowadays, a variety of car jacks have been developed for lifting an automobile from a ground surface. Available car jacks, however, are typically manually operated and therefore require substantial laborious physical effort on the part of the user. Such jacks present difficulties for the elderly and handicapped and are especially disadvantageous under bad weather conditions [2].

In light of such inherent disadvantages, commercial automobile repair and service stations are commonly equipped with large and hi-tech car lift, wherein such lifts are raised and lowered via electrically-powered systems [3]. However, due to their size and high costs of purchasing and maintaining electrically-powered car lifts, such lifts are not available to the average car owner. Such electrical-powered portable jacks not only remove the arduous task of lifting an automobile via manually-operated jacks, but further decrease the time needed to repair the automobile. Such a feature can be especially advantageous when it is necessary to repair an automobile on the side of a roadway or under other hazardous conditions [4].

There also reports on car jacks which lead to a serious number of accidents. A specified jack purposed to hold up to 1000 kilograms, but tests undertaken by Consumer Affairs has revealed that it fails to work after lifting 250 kilograms and may physically break when it has a weight close to its 1000 kilograms capacity [3]. Tests have proven that the jack

has the propensity to buckle well under the weight it is promoted to withstand, and it doesn't meet the minimum or performance requirements of the Australian Standard for vehicle jacks [5]. The purpose of this project is to develop a car jack which is easy to be operated, safe and able lift and lowering the car without involving much physical effort.

THE DEVELOPMENT

Figure 1 shows the design of automatic car jacker where:

1. Original Scissor jack
2. Screw shaft
3. Power window motor
4. Pinion
5. Gear
6. Frame holder
7. Stabilizer base

Furthermore, Figure 2 is the actual prototype of the automatic car jack. The entire requirement from the drawing is then transform onto the real prototype. It also included a switch buttons system to raise and lowering the jack (Head load). Figure 1, shows the used scissor jack which has been collected from the junk yard and it still can be used. The

scissor jack is the best jacks available in the market. According to Farhad, the pneumatic and hydraulic jack is not safe because usually need maintenance and sometime leaked [6]. The development will be base on this scissor jack. The screw shaft which can be rotated and raise the head load up and down. The screw shaft is very important because in this design will need a system which can withstand the load and lock the raised level of the jack. The screw will be the mechanism to adjust and hold the height level.

The motor is from the junk yard and it is from used car power window motor. From the manufacturer and calculated value for the torque, it supplied 5.877N.m torque which is high enough and suitable for the project [7]. There is also the pinion (small) and the gear (large) which is the main gearing system as shown in figure 3. This is the gearing system which increased the torque to 17.631N.m [8]. Furthermore, the frame is the holder for the power window motor. Lastly, the stabilizer base is to support the weight of the motor and to stabilize the scissor jack. It is also good for flat surface when jacking the car [9].

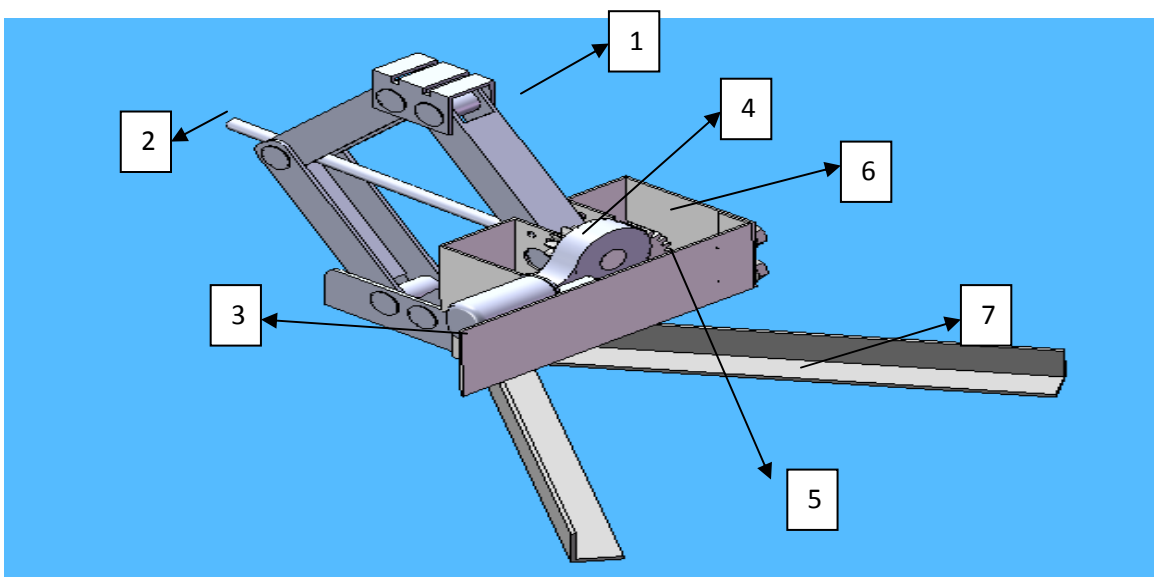

Figure 1. Design from Solidwork



Figure 2. Developed prototype

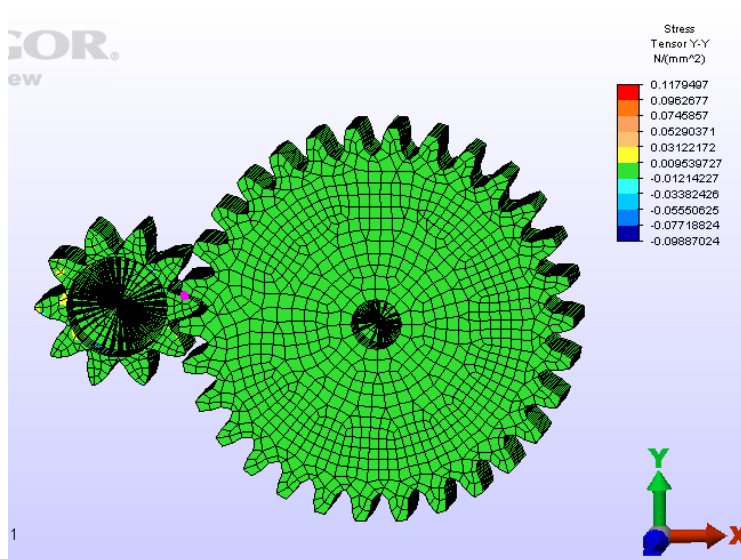

Figure 3. Gearing system

MECHANICAL PARTS

The mechanism lifting system was applied on the scissor jack. The scissor jack specific

description is it can withstand the maximum load of 850kg which is the best because the test car for this project is a PERODUA Kancil® (682kg) [10].The test will be detailed

explained in the result.No.3 is the motor which the original gear needed to be discarded because no. 4, pinion and no. 5, gear are manufactured using wire EDM cutting machine. All the specification of the gears according to the torque needed to be applied on the system [11]. The gearing system is the crucial thing as it is the lifting mechanism powered from the motor. The torque from the motor will be supplied to the pinion and then transmit to the gear and it rotated the screw shaft clockwise or counter- clockwise.

By using the wire EDM cutting machine, the operator needed to insert the drawing that has been made and then program the machine so it will work. After the no.4 pinion is fabricated, it is inserted into the slot of the power window motor and welded. The no.6 frame is fabricated base on the design to hold the

motor. It is fabricated using 3mm low carbon metal and then cut using grinder into small pieces according the dimensions [5]. The cut pieces are then welded on the end of the scissor jack and welded together with other pieces as the picture shown.

The welding machine that involved is MIG machine (Metal Inert Gas).No 7 is the stabilizer base which is made from the L iron bar [8]. The length of each iron bar is 30cm and then is screwed and welded on the base of the scissor jack. This is to stabilize the scissor jack with increasing of the surface area will increase the stability [5]. Moreover, bending machine is also used to bend the cover for the gearing system and bend saw machine is used to cut the raw material for the gear. Fabricated gear shown in Figure 4.



Figure 4. Fabricated gear

Base on Figure 5, switch for the scissor jack to be lifted and lowered are controlled by a 2

buttons switch with ON/OFF. This switch circuit is to make the motor enabled to rotate

clockwise and counter-clockwise without changing the terminal positive and negative. It is time consumable to change the terminal every time when using this jack, so by using this switch, it is more flexible and easier for the user. The switch also contains 2 relays which will act when a lifting button is press it will actuate one of the relay and it will rotate the motor to the desire level. The most

important part is that when the button is release it will stop directly. Let say if the red button is pressed, then it will actuated the coil in relay 1 and then it will change over the switch and supply will flow to the motor and to the second relay which will go directly to negative terminal and the motor will rotate clock-wise. Vice versa, if the black button is pressed [11].

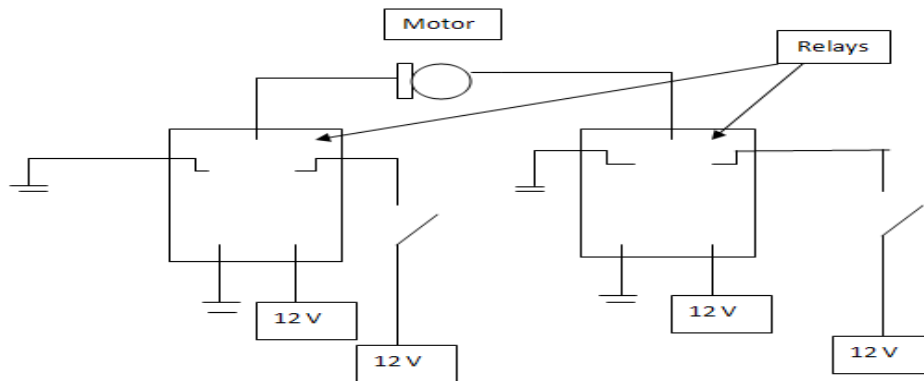

Figure 5: Switch circuit

CONSLUSIONS

Considering all available car jacks in the market, this prototype can be improved by a few modifications on the features and design. The objectives are to design a car jack that is safe, reliable and able to raise and lower the level, to develop a car jack that is powered by internal car power and automated with buttons system. Although this car jack was design

only on PERODUA Kancil, by using higher torque it is able to lift more loads such as Proton Wira® and Proton Iswara® car.

Acknowledgments The financial support by University Malaysia Pahang (UMP) and final year student Amir Iskandar Bin Ariffin is grateful acknowledged.

REFERENCES

1. American Lift Institute, ALI brochure 'Automotive Lift - Purchase Considerations'. July 2004.
2. Australian Competition and Consumer Commission, Department of Health and

- ageing 'Safety Alert working under a vehicle'. Brochure 2007.
3. Boston Jacks Corporation, jacking beams Manufacturer ISO 9002 (BS5750) 500 Gale Street Dagenham Essex RM9 4NU.Tel: +44 (0)20 8593 7514 Fax: +44 (0)20 8595 2923, www.boston-ge.com (Oct 2008).
 4. Edward M.Lonon, East Orange,N.J,US .'Motorized Jack'. United States Patent. Patent number: 5085407.Date of Patent: Feb 4, 1992.
 5. Farhad Razzaghi, Douglasville, GA, US. 'Apparatus and Method for an Electric Jack'. United States Patent. Patent number: US2007/0256526 A1.Date of patent: Nov 8,2007
 6. Hon Jennifer Rankine, Minister for Consumer Affairs, Government of South Australia. News release: 'Vehicle jack that can't stand the strain' Tuesday 31st July 2007
 7. Jay Heizer and Barry Render, *Operations Management*, Sixth Edition: Pearson International Edition. 2006.
 8. Joseph E.Shigley, 7th edition, *Mechanical engineering Design*, 2004
 9. Kalpakjian S. and Schmid S.R *Manufacturing Engineering and Technology*. Fourth Edition: Prentice Hall International, 2001.
 10. Mackubin Thomas Owens. The Washington Times: USMA report on the Integration and Performance of Women at West Point. Oct 10, 1998.
 11. Pat L. Mangonon ,*The Principles of materials selection for engineering design*, Design, selection, and failure of materials, pg 432, 1999.
 12. Pat L. Mangonon, *The Principles of materials selection for engineering design*, Design, selection, and failure of materials, pg 433-436, 1999.
 13. Steve Levenstein, US. 'Railcar jack Assembly' US Patent Issued on September 11, 1993, Patent number: 5876018.
 14. William H. Crouse and Donald L. Anglin, *Automotive Mechanics* 10th edition, 1993
 15. Yang-chou Liu, Taipei, Taiwan. 'Manually operated car jack' United States Patent. Patent number: 5603486.Date of Patent: Feb 18, 1997.