

MICROCONTROLLER BASE FULL BRIDGE FORWARD
POWER SUPPLY UNIT

MUHAMAD AZIZAN BIN MAT SIRAT

This thesis is submitted as partial fulfillment of the requirements for the award of the Bachelor of Electrical Engineering (Hons.) (Power Systems)

Faculty of Electrical & Electronics Engineering
Universiti Malaysia Pahang

OCTOBER, 2008

ACKNOWLEDGEMENT

In the name of Allah, The Most Loving and The Most Compassionate

I would like to take this opportunity to extend my deepest gratitude to the following persons who helped me a lot in this project, which enabled me to complete my research project in time as a partial of the requirement for the Bachelor of Electrical Engineering (Power Systems).

First and foremost, a special thank to my supervisor En. Mohammad Fadhil bin Abas, who helped me a lot for the project research, for all the support, continuous patience, and supervision given throughout the project.

I would like to give my appreciation to Mr. Mohd Azlan bin Sayuti for his valuable time spent in giving his authority to use his laboratory. His laboratory helped me in doing analysis and further studies for this project.

Thank you to my classmates with their encouragement and help. Last but not least, my special thanks, to my family members for their continuous support and advice from the early stage of my studies.

ABSTRACT

Nowadays, there are many power supply unit topologies. In this project, it is been proposed to do the full-bridge dc-dc converter topology. The full-bridge dc-dc converter topology was chosen for several reasons. The primary benefit of using a Full-Bridge dc-dc converter is its power handling capabilities, stability, and symmetry. Secondly, using a high frequency transformer is one of the most efficient ways to step up or step down the voltage and to transfer the power to the full-wave rectifier circuit. Basically, this topology is referred to the use of switch mode power supply (SMPS) technique. In designing SMPS, it used high frequency transformer. The purpose of a power transformer in Switch-Mode Power Supplies is to transfer power efficiently and instantaneously from an external electrical source to an external load. In doing so, the transformer also provides important additional capabilities. As mentioned just now, this design uses the high frequency switch. Therefore, a controller is needed to control or vary the duty cycle of PWM during switching time. In this design, PIC is chosen as the main controller of this PSU. PIC was chosen because of ease to program the switching time of four switches. Normally, MOSFET or IGBT is selected for the power switch. Circuit driver is also needed to drive voltage signal from PIC to the power switches. In this case, suitable IC driver must be used.

ABSTRAK

Dewasa ini, terdapat banyak jenis kaedah dalam menghasilkan bekalan kuasa. Dalam projek ini, ditugaskan membuat kaedah *full-bridge dc-dc converter*. Kaedah *full-bridge dc-dc converter* dipilih disebabkan beberapa faktor. Kelebihan utama dengan menggunakan kaedah ini adalah kelebihan dari aspek *power handling*, *stability*, dan *symmetry*. Kemudian, dengan menggunakan transformer frekuensi tinggi adalah satu cara yang lebih efisien untuk meningkatkan atau menurunkan voltan dan memindahkan kuasa kepada litar *full-wave rectifier*. Pada asasnya, kaedah ini dirujuk sebagai teknik *switch mode power supply* (SMPS). Dalam menghasilkan SMPS, ia menggunakan transformer frekuensi tinggi. Tujuan transformer frekuensi tinggi dalam SMPS adalah untuk memindahkan kuasa secara efisien dan berterusan daripada sumber elektrik luar kepada beban luar. Dengan cara ini, transformer juga akan membekalkan keupayaan tambahan. Seperti yang saya jelaskan tadi, projek ini menggunakan suis berfrekuensi tinggi. Oleh sebab itu, pengawal diperlukan untuk mengawal atau mengubah *duty cycle* PWM. Dalam projek ini, PIC dipilih sebagai pengawal utama. PIC dipilih kerana ia mudah untuk memprogramkan masa suis bagi empat suis. Kebiasaanya, MOSFET atau IGBT dipilih untuk suis kuasa. Litar penggerak juga diperlukan untuk membawa voltan daripada PIC kepada suis kuasa. Dalam hal ini, penggerak yang sesuai mesti digunakan.

TABLE OF CONTENTS

CHAPTER	TITLE	PAGE
	TITLE PAGE	i
	DECLARATION	ii
	ACKNOWLEDGEMENT	iii
	ABSTRACT	iv
	ABSTRAK	v
	TABLE OF CONTENTS	vi
	LIST OF TABLES	ix
	LIST OF FIGURES	x
	LIST OF APPENDIXES	xii
1	INTRODUCTION	1
	1.1 Introduction	1
	1.2 Objectives	3
	1.3 Scope of Project	4
2	LITERATURE REVIEW	5

3	METHODOLOGY	8
3.1	Simulation Design	9
3.2	Hardware Development	9
3.2.1	Developing	9
3.2.2	Designing	12
3.3	Component Determination	17
3.3.1	Capacitor and Resistor	17
3.3.2	Bridge Rectifier	17
3.3.3	Transformer	17
3.3.4	Controller	18
3.3.5	Power Switch	18
3.3.6	Power Switch Driver	19
3.4	Software Development	19
3.4.1	Peripheral Programming	21
4	RESULT AND DISCUSSION	22
4.1	Simulation Result	22
4.2	Hardware Result	27
4.2.1	Driver Circuit Design	27
4.2.2	PIC Circuit Design	30
4.2.3	Designing High Frequency Transformer	31
4.2.4	Designing Power Supply	35
4.2.5	Designing Circuit Feedback	35
4.2.6	Designing Full Bridge DC-DC Converter	36

4.3	Software Design	37
4.4	Costing and Commercialization	41
5	CONCLUSION AND RECOMMENDATIONS	44
5.1	Summary of Work	44
5.2	Future Recommendations	45
REFERENCES		46
APPENDICES		
APPENDIX A	Sample of Full Program to Generate Two PWM With Feedback	47
APPENDIX B	Picture of Full Project	52
APPENDIX C	Picture of Output Results	53

LIST OF TABLES

TABLE NO.	TITLE	PAGE
1	Summarize Calculation Value	16
2	Range of Voltage of Feedback Circuit	39
3	Revised Material Cost	41

LIST OF FIGURES

FIGURE NO.	TITLE	PAGE
1	Block Diagram of Project	9
2	A Simple Program of Generating Two PWMs	21
3	Simulated Design Circuit of the First Stage of the Project	23
4	Simulated Design Circuit of the Second Stage of the Project	23
5	Graph of Single Phase Supply Voltage	24
6	Graph of Input Filtering (dc supply)	24
7	Graph of Primary Voltage Transformer	25
8	Graph of Secondary Voltage Transformer	25
9	Graph of Desired Output Voltage	26
10	Driver Circuit for Half-bridge	28
11	High-side Signal	28
12	Low-side Signal	28
13	Full-bridge Driver Circuit	29
14	Square-wave Output	29
15	PIC18F4550 Circuit	30
16	Transformer Housing	31
17	Transformer Clips	31

18	Ferrite	32
19	Copper Coil (2.5A)	32
20	Black Tape	32
21	Windings are being made	33
22	Black Tape is used to provide Isolation	33
23	Inductance Measurement Meter	34
24	Power Supply 5Vdc and 15Vdc	35
25	Circuit Feedback	36
26	Full Schematics of Full Bridge DC-DC Converter	
	Power Supply Unit	37
27	Flow Chart of the Program	40

LIST OF APPENDICES

APPENDIX	TITLE	PAGE
A	Sample of Full Program to Generate Two PWMs with Feedback	47
B	Picture of Full Project	52
C	Picture of Output Results	53

CHAPTER 1

INTRODUCTION

1.1 Introduction

Nowadays, there are many power supply unit topologies. Among of the topologies are buck dc-dc converter, boost dc-dc converter, buck-boost dc-dc converter, flyback dc-dc converter, push-pull dc-dc converter, half-bridge dc-dc converter, and full-bridge c dc-dc converter. In this project, it is proposed to do the full-bridge dc-dc converter topology. The full-bridge c dc-dc converter topology was chosen for several reasons. The primary benefit of using a Full-Bridge dc-dc converter is its power handling capabilities, stability, and symmetry. Secondly, using a high frequency transformer is one of the most efficient ways to step up or step down the voltage and to transfer the power to the full-wave rectifier circuit. The high frequency transformer is also much smaller and lighter than a standard 8.5 kVA 60 Hz transformer. Basically, this topology is referred to the use of switch mode power supply (SMPS) technique.

A switched-mode power supply, switching-mode power supply or SMPS, is an electronic power supply unit (PSU) that incorporates a switching regulator. While a linear regulator uses a transistor biased in its active region to specify an output voltage,

an SMPS actively switches a transistor between full saturation and full cutoff at a high rate. The resulting rectangular waveform is then passed through a low-pass filter (typically an inductor and capacitor) to achieve an approximated output voltage.

Advantages of this method include smaller size, better power efficiency, and lower heat generation. Disadvantages include the fact that SMPSs are generally more complex than linear supplies, generate high-frequency electrical noise that may need to be carefully suppressed, and have a characteristic ripple voltage at the switching frequency.

In designing SMPS, it used high frequency transformer. The purpose of a power transformer in Switch-Mode Power Supplies is to transfer power efficiently and instantaneously from an external electrical source to an external load. In doing so, the transformer also provides important additional capabilities. Among of the important additional capabilities are the primary to secondary turns ratio can be established to efficiently accommodate widely different input/output voltage levels, multiple secondary with different numbers of turns can be used to achieve multiple outputs at different voltage levels, and separate primary and secondary windings facilitate high voltage input/output isolation, especially important for safety in off-line applications.

As mentioned just now, this design uses the high frequency switch. Therefore, a controller is needed to control or vary the duty cycle of PWM during switching time. In this design, PIC is chosen as the main controller of this PSU. PIC was chosen because of ease to program the switching time of four switches. Normally, MOSFET or IGBT is selected for the power switch. Circuit driver is also needed to drive voltage signal from PIC to the power switches. In this case, suitable IC driver must be used.

1.2 Objectives

The objective of this project:

- i. To produce a high frequency power supply by using switch mode power supply technique (SMPS). Linear power supplies use a transformer operating at the mains frequency of 50 or 60 Hz. This low-frequency transformer is several times larger and heavier than a corresponding transformer in an SMPS, which runs at typical frequencies of 50 kHz to 1 MHz
- ii. Provide high efficiency and less loss during switching time. A linear supply regulates the output voltage or current by expending excess power as heat, which is inefficient. A regulated SMPS will regulate the output using duty cycle control, which draws only the power required by the load. In all SMPS topologies, the transistors are always switched fully on or fully off. Thus, ideally, SMPSs are 100% efficient. The only heat generated is in the non-ideal aspects of the components. Switching losses in the transistors, on-resistance of the switching transistors, equivalent series resistance in the inductor and capacitors, and rectifier voltage drop will lower SMPS efficiency. However, by optimizing SMPS design, the amount of power loss and heat can be minimized. A good design can have an efficiency of 95%.
- iii. Provide isolation to PSU by using high frequency transformer. All transformers provide dc isolation between isolated windings. However, because they all have capacitance from a winding to any nearby conductor, such as other windings, the core, and the chassis, they can couple high frequency signals and noise to these nearby conductors. This capacitive coupling mechanism can carry high frequency noise on the input primary to the output secondary windings or vice versa. Isolation transformers are designed to minimize this coupling by construction that minimizes capacitive coupling, or by the use of shields, or both.

- iv. The designed power supply must meet the requirement that is output voltage is 30Vdc, output current at maximum 5A, and power efficiency at least 80%.

1.3 Scope of Project

Among of the scope of project are:

- i. Design a rectifier circuit to produce dc output voltage from $240V_{\text{rms}}$.
- ii. Design a full-bridge power supply unit using switch mode power supply (SMPS) technique
- iii. Design a controller to control the duty cycle of pulse with modulation (PWM) during switching time
- iv. Design the high frequency transformer

CHAPTER 2

LITERATURE REVIEW

Basically, there are two types of power supply. One is linear power supply (conventional power supply unit) and the other one is switch mode power supply (SMPS). Switch Mode Power Supplies are the current state of the ability in high efficiency power supplies. Conventional series-regulated linear power supplies maintain a constant voltage by varying their resistance to cope with input voltage changes or load current demand changes. The linear regulator can, therefore, tend to be very inefficient. The switch mode power supply, however, uses a high frequency switch (in practice a transistor) with varying duty cycle to maintain the output voltage. The output voltage variations caused by the switching are filtered out by an LC filter (C J Hill, 1997).

Full-bridge dc-dc converter power supply unit topology is chosen for certain factors. Full-bridge dc/dc converters are extensively applied in medium to high power dc/dc power conversion. High efficiency, high power density, high reliability and low EMI are some of the most desirable features for these converters, particularly for computer and telecommunication applications (Dheeraj K. Jain, Praveen K. Jain and Haibo Zhang, 2002).

Full bridge and half-bridge topologies with full bridge secondaries have the best transformer efficiency because the core and the windings are fully utilized. With center-

tapped secondaries, winding utilization and efficiency are reduced. With center tapped primary *and* secondaries, winding utilization and efficiency are further reduced. All of the push pull topologies have the further advantage that for a given switching frequency, giving the same output ripple filtering and closed loop capability, the frequency at which the transformer core and windings operate is halved, reducing core and ac winding losses (Lloyd H. Dixon, 2001).

There are three major power switch choices; the bipolar junction transistor (BJT), the power MOSFET, and the integrated gate bipolar transistor (IGBT). The BJT was the first power switch to be used in this field and still offers many cost advantages over the others. It is also still use for very low cost or in high power switching converters. The maximum frequency of operation of bipolar transistor is less than 80-100 kHz because of some of their switching characteristics. The IGBT is used for high power switching converters, displacing many of the BJT applications. They too, though, have a slower switching characteristic which limits their frequency of operation to below 30 kHz typically although some can reach 100 kHz. IGBT's have smaller die areas than power MOSFETs of the same ratings, which typically means a lower cost. Power MOSFETs are used in the majority of applications due to their ease of use and their higher frequency capabilities (ON Semiconductor, July 2002).

Before using power switches, firstly circuit driver must be constructed. To design circuit driver, all the requirements possibility must be obeyed. Mostly, the requirements are gate driver voltage, incoming dc voltage, incoming dc current and input protection for the driver and the power switch. All these possibilities must be followed to ensure the system functional and safety to be implemented.

After completing several stages, the designed high frequency transformer could not simply connected to the MOSFET (switching). Some additional circuit must be constructed and added between connection of MOSFET and high frequency transformer. When the MOSFET turns off, a high-voltage spike occurs on the drain pin because of a resonance between the leakage inductor (L_{lk}) of the main transformer and the output capacitor (COSS) of the MOSFET. The excessive voltage on the drain pin

may lead to an avalanche breakdown and eventually damage the MOSFET. Therefore, it is necessary to add an additional circuit to clamp the voltage. This circuit is known as RCD Snubber Clamp for transformer (Design RCD Snubber, 2006).

Finally, the use of microcontroller (PIC) as a main controller of the full-bridge dc-dc converter power supply unit. PIC acts to give pulse width modulation (PWM) signal to the power switches throughout the driver circuit. The value or the ratio of PWM is calculated depending from desired output signal. Besides that, PIC works as a feedback to maintain the output signal if there any overvoltage or over current to the output.

CHAPTER 3

METHODOLOGY

There are some steps will be applied in designing a microcontroller base full-bridge forward power supply unit. The necessary and related information have been discovered throughout the literature review.

In this methodology, I have separated into three elements. Among of the elements are:

- i. Simulation Design
- ii. Hardware Development
- iii. Software Development

3.1 Simulation Design

OrCAD PSpice is chosen to simulate the circuit designed. In this simulation, it will show the simulated output results. This simulation is very essential to keep all theoretical design and calculation is suitable to the project designed. Besides that, it can give clear view of the project according the obtained simulation output.

3.2 Hardware Development

3.2.1 Developing

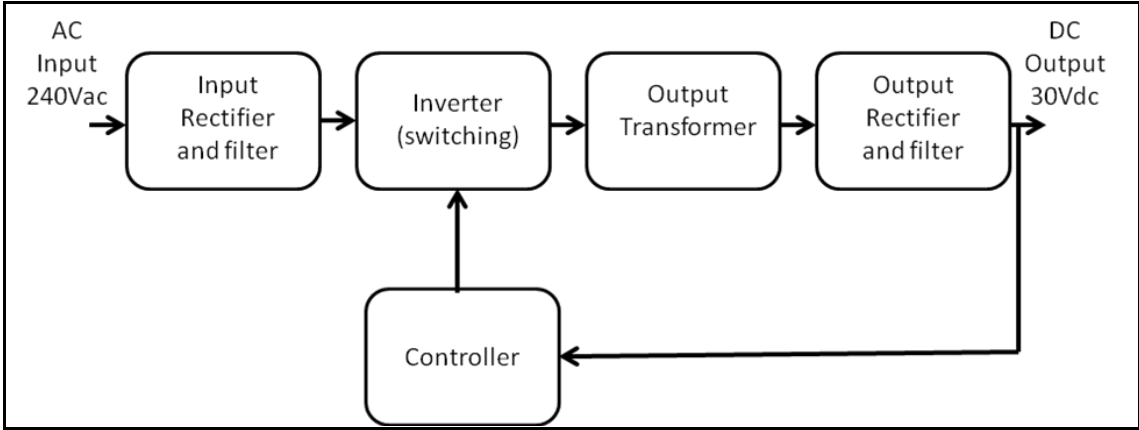

Figure 1 Block Diagram of Project

In this developing, hardware design will be constructed. From above figure, it shows each stage for the hardware design. Among of the stages are input rectifier and filter, inverter (switching), output transformer (high frequency transformer), output rectifier and filter, and controller. The hardware development will be completed by following each stages of the block diagram.

3.2.1.1 Input Rectifier and Filter

If the SMPS has an AC input, then its first job is to convert the input to DC. This is called rectification. The rectifier circuit can be configured as a voltage doublers by the addition of a switch operated either manually or automatically. This is a feature of larger supplies to permit operation from nominally 240 volt supplies. The rectifier produces an unregulated DC voltage which is then sent to a large filter capacitor.

3.2.1.2 Inverter (switching)

The inverter stage converts DC, whether directly from the input or from the rectifier stage described above, to AC by running it through a power oscillator, whose output transformer is very small with few windings at a frequency of tens or hundreds of kilohertz (kHz). The frequency is usually chosen to be above 20 kHz, to make it inaudible to humans. The output voltage is optically coupled to the input and thus very tightly controlled. The switching is implemented as a multistage (to achieve high gain) MOSFET amplifier. MOSFETs are a type of transistor with a low on-resistance and a high current-handling capacity.

3.2.1.3 Output Transformer, Rectifier and Filter

If the output is required to be isolated from the input, as is usually the case in mains power supplies, the inverted AC is used to drive the primary winding of a high-frequency transformer. This converts the voltage up or down to the required output level on its secondary winding. The output transformer in the block diagram serves this purpose.

If a DC output is required, the AC output from the transformer is rectified. For output voltages above ten volts or so, ordinary silicon diodes are commonly used. For lower voltages, Schottky diodes are commonly used as the rectifier elements; they have the advantages of faster recovery times than silicon diodes (allowing low-loss operation at higher frequencies) and a lower voltage drop when conducting. For even lower output voltages, MOSFET transistors may be used as synchronous rectifiers; compared to Schottky diodes, these have even lower "on"-state voltage drops.

The rectified output is then smoothed by a filter consisting of inductors and capacitors. For higher switching frequencies, components with lower capacitance and inductance are needed.

3.2.1.4 Controller

A feedback circuit monitors the output voltage and compares it with a reference voltage, which is set manually or electronically to the desired output. If there is an error in the output voltage, the feedback circuit compensates by adjusting the timing with which the MOSFETs are switched on and off. This part of the power supply is called the switching regulator. The "controller" shown in the block diagram serves this purpose. Depending on design/safety requirements, the controller may or may not contain an isolation mechanism (such as opto-couplers) to isolate it from the DC output.

Open-loop regulators do not have a feedback circuit. Instead, they rely on feeding a constant voltage to the input of the transformer or inductor, and assume that the output will be correct. Regulated designs work against the parasitic capacity of the transformer or coil, monopolar designs also against the magnetic hysteresis of the core.

The feedback circuit needs power to run before it can generate power, so an additional non-switching power-supply for stand-by is added.

3.2.2 Designing

In this designing all the inputs and the outputs are identified. Theoretical design and calculation is studied base on the project. Each component will be used for the project is identified whether it is contented for the recommendation design or not. So, hand calculation is needed to identify the value of each components based on the theoretical design.

3.2.2.1 Input Rectifier and Filter

The design specification was given as follows:

Supply voltage: 240V/50Hz

Maximum power required: $P_o = 150W$

Thus, average voltage (peak voltage)

$$V_p = \sqrt{2} \times 240V = 339.41V \quad (3.1)$$

Ideal power

$$P_{in} = P_{out} = P_{rec}$$

$$P_{rec} = V_{rec} \times I_{rec} \quad (3.2)$$

Where; V_{rec} = output voltage of rectifier

I_{rec} = output current of rectifier

Therefore,

$$I_{rec} = \frac{P_{i_n}}{V_{i_n}} = \frac{150W}{339.41V} = 0.442A \quad (3.3)$$

Load (resistor)

$$P_{rec} = V_{rec} \times I_{rec}$$

$$P_{rec} = \frac{V_{rec}^2}{R}$$

$$R = \frac{V_{rec}^2}{P_{rec}} = \frac{339.41^2}{150} = 767.99\Omega \quad (3.4)$$