

**PURIFICATION OF CLOVE OIL VIA MIDDLE VESSEL BATCH  
DISTILLATION**

**NURUL SHAMSINAR BINTI SHAHIRIN**

**A report submitted in fulfillment of requirements for the award of the Degree of  
Bachelor of Chemical Engineering**

**Faculty of Chemical Engineering and Natural Resources  
Universiti Malaysia Pahang**

**KUANTAN, PAHANG**

**MAY 2008**

“I declare that this thesis is the result of my own research expect as cited references.

The thesis has not been accepted for any degree is concurrently submitted in  
candidature of any degree.”

Signature :.....

Name of Candidate : NURUL SHAMSINAR BINTI SHAHIRIN

Date : 16 MAY 2008

*In the name of Allah*

*To my beloved parents and family*

## ACKNOWLEDGEMENT

In the name of Allah, I am very thankful to Him because allowed and give me strength to finish this thesis. In particular, I wish to express my sincere appreciation to my supervisor, Ms. Siti Zubaidah bt. Sulaiman for her encouragement, guidance and advices in order to finish my project. A lots of thank also I regard to my co-supervisor, Mr. Anwaruddin Hisyam whose give efforts and guideline to me in finishing this project. They have contributed towards my understanding and thoughts during this project development. Without their continued support and interest, this thesis would not be a success.

I am also indebted to the staff of Faculty of Chemical and Natural Resources Engineering especially to Vocational Officer for their kindness and cheerfulness in gives their hand while conducting my project.

Special thankful is also extends to all my colleagues and others who have provided assistance at various occasions. Their views and tips are useful indeed. Lastly, but not least I regard my special thank and love to my parents and other family members for their continuous support while completing this project.

## ABSTRACT

Batch distillation process is becoming increasingly important because of its flexibility. However, regular batch distillation required high energy consumption and high residence time in the column. Middle Vessel Batch Distillation is one of the alternative configurations to overcome these problems. In this study, Middle Vessel Batch Distillation is used to purify crude clove oil. The scopes of this study are based on the effects of vessel holdup and operating time of distillation process. The objectives are to obtain the separation performance of clove oil by using middle vessel batch distillation column and to find out the effects of time and the middle vessel holdups to the composition of *Eugenol* in clove oil. The samples of clove oil after the process are analyzed by Gas Chromatography. The performance separation of the Middle Vessel Batch Distillation column is fully understood. It is proven that by varying vessel holdup and operating time, the separation performance are improved.

## ABSTRAK

Turus penyulingan berkelompok merupakan satu peralatan untuk proses penulenan bahan kimia yang amat efektif dan luas penggunaannya di dalam industri farmasi. Penyulingan berkelompok menjadi proses penting di dalam industri kerana sifat yang fleksibel. Dalam kajian ini, Penyulingan Berkelompok dengan Tangki Tengah digunakan sebagai salah satu cara untuk menulenan minyak cengkih mentah. Skop untuk kajian ini adalah berdasarkan kesan penghadang tangki dan masa operasi kepada proses penyulingan. Tujuan kajian ini adalah untuk mengenalpasti prestasi pemisahan minyak cengkih menggunakan turus Penyulingan Berkelompok dengan Tangki Tengah. Selain itu, mengenalpasti kesan penghadang tangki dan masa operasi ke atas komposisi minyak cengkih. Sampel daripada eksperimen akan dianalisis menggunakan Kromatografi Gas. Eksperimen ini dapat mengenalpasti penghadang tangki yang terbaik untuk mendapatkan komposisi *Eugenol* yang tertinggi. Selain itu, ia juga dapat mengurangkan masa operasi proses berbanding menggunakan penyulingan berkelompok biasa.

## TABLE OF CONTENTS

CHAPTER	TITLE	PAGE
	<b>TITLE PAGE</b>	<b>i</b>
	<b>DECLARATION</b>	<b>ii</b>
	<b>DEDICATION</b>	<b>iii</b>
	<b>ACKNOWLEDGEMENT</b>	<b>iv</b>
	<b>ABSTRACT</b>	<b>v</b>
	<b>ABSTRAK</b>	<b>vi</b>
	<b>TABLE OF CONTENT</b>	<b>vii</b>
	<b>LIST OF SYMBOLS</b>	<b>ix</b>
	<b>LIST OF FIGURES</b>	<b>x</b>
	<b>LIST OF TABLES</b>	<b>xii</b>
	<b>LIST OF APPENDICES</b>	<b>xiii</b>
<b>1</b>	<b>INTRODUCTION</b>	<b>1</b>
	1.1 Background of Study	1
	1.2 Problem Statement	4
	1.3 Objective	5
	1.4 Scope	5
<b>2</b>	<b>LITERATURE REVIEW</b>	<b>7</b>
	2.1 Purification	7
	2.2 Essential oil	8
	2.2.1 Clove oil	9

	2.2.2	<i>Eugenol</i> and the Importance	10
	2.2.3	Reaction of <i>Eugenol</i>	12
	2.3	Batch Distillation in Theory	12
	2.4	Middle Vessel batch Distillation	16
	2.4.1	Advantages of Middle Vessel Batch Distillation operation	19
	2.4.2	Total Reflux policy operation	20
	2.5	Vessel holdup and Operating time	21
	2.6	Gas Chromatography	22
<b>3</b>		<b>METHODOLOGY</b>	24
	3.1	Material	24
	3.2	Experimental	25
	3.3	Sample preparation for Gas Chromatography analysis	28
	3.4	Analysis Method	30
<b>4</b>		<b>RESULT AND DISCUSSION</b>	32
<b>5</b>		<b>CONCLUSION AND RECOMMENDATIONS</b>	42
	5.1	Conclusion	42
	5.2	Recommendations	43
		<b>LIST OF REFERENCES</b>	44
		<b>APPENDICES</b>	46



**LIST OF SYMBOLS**

$T$	-	Temperature
$t$	-	Time
$F^{in}$	-	Volumetric feed rate to the column
$V'$	-	Molar vapor boilup rate
$D$	-	Molar distillate rate
$H$		Vessel Holdup

## LIST OF FIGURE

<b>FIGURE</b>	<b>TITLE</b>	<b>PAGE</b>
2.1	Clove buds and leaves	9
2.2	Batch Rectifier	14
2.3	Batch Stripper	16
2.4	Principle structure of Middle Vessel Batch Distillation	18
2.5	A schematic diagram of basic Gas Chromatography	22
3.1	Middle Vessel Batch Distillation at Lab FKKSA	24
3.2	Vessel holdup for middle and top vessel	25
3.3	Flowchart of experimental procedures Middle Vessel Batch Distillation	26
3.4	Products after distillation via Middle Vessel Batch Distillation	27
3.5	Flow of sample preparation for GC analysis	28
3.6	Sample for GC analysis	28
3.7	Gas Chromatography in FKKSA laboratory	29
3.8	Process Flow Diagram	30
4.1(a) (b) (c) (d)(e)	Graph Temperature vs time at Atmospheric pressure	32

4.2(a)(b)(c)(d)	Graph Temperature vs time at Vacuum pressure	35
4.3	Sample Analysis Result GC	38

**LIST OF TABLE**

<b>TABLE</b>	<b>TITLE</b>	<b>PAGE</b>
1.1	Identified constituents in Clove oil	2
2.1	Properties of <i>Eugenol</i>	11
4.1	Data from Calculation of Composition	39

**LIST OF APPENDICES**

<b>APPENDIX</b>	<b>TITLE</b>	<b>PAGE</b>
A	GC Analysis Result	47
B	GC Analysis Data Calculation	62

## **CHAPTER 1**

### **INTRODUCTION**

#### **1.1 Background of Study**

Nowadays, fine chemicals have high value added in market. High demands from the industries give results to the increasing production of fine chemicals. New development in industries especially in pharmaceutical, cosmetics, foods, and aromatic application, fine chemicals become the main ingredient to these productions. Essential oil is one of the valuable fine chemicals. Jasmine oil, Gaharu oil, Chamomile oil, Clove oil, Garlic oil and Ginger oil are some of the essential oil that widely used in aromatherapy, foods and pharmaceutical uses. In aromatherapy, essential oil can give relaxation, release stress and powerful in healing body ability. Essential oil used as the best flavor in foods industries. Pharmaceutical research gives results that some of

essential oil is used as main ingredient in the medicine. In conclusion, benefits of essential oil are infinite and nowadays essential oil has high value added in market.

Clove oil is one of the essential oil that exists in the world. Clove oil was extracted from the clove buds. Figure 1.1, shows the clove buds which clove oil is extracted from. It is used in pharmaceutical and aromatherapy. There are multicomponent compositions in the clove oil such as esters, aldehydes, terpenes eugenol and others. However, *Eugenol* is an active ingredient in clove essential oil. *Eugenol* is important in the dental pain relief. It is also used in numbing the gums. There is about 80% of *Eugenol* in the clove oil. Figure 1.1 shows table of composition and olfactic data of clove oil analyze by Gas Chromatography (Jirovetz *et. al*, 2006)

**Table 1.1:** Identified constituents in clove oil

compound <sup>a</sup>	Ri <sup>b</sup>	percent <sup>c</sup>	odor description <sup>d</sup>	identification <sup>e</sup>
limonene	1029	0.1	fresh, herbaceous, lemon	reference
1,8-cineole	1032	0.1	fresh (eucalyptus-like)	reference
cis-limonene oxide	1137	trace	fresh, mild, citrus note	tentative
trans-limonene oxide	1142	trace	fresh, warm, sweet orange	tentative
methyl salicylate	1190	0.1	minty, sweet, spicy	reference
methylchavicol	1195	0.2	sweet, anise note, minty	reference
chavicol	1248	0.1	anise-like, spicy, green minty	reference
eugenol	1359	76.8	spicy (clove cinnamon-like)	reference
methyleugenol	1403	trace	spicy (clove-like)	reference
cis-isoeugenol	1407	trace	spicy, weak clove note	reference
$\beta$ -caryophyllene	1415	17.4	spicy woody, terpene note	reference
trans-isoeugenol	1449	0.1	spicy, weak clove note	reference
$\alpha$ -clove	1452	trace	mild spicy	tentative
cis-methylisoeugenol	1455	trace	clove-like, spicy, aromatic	reference
$\alpha$ -humulene	1458	2.1	woody spicy	reference
trans-methylisoeugenol	1491	trace	clove note, mild spicy	reference
$\alpha$ -farnesene	1506	0.1	floral oily, weak spicy	reference
eugenyl acetate	1522	1.2	clove-like, balsamic sweet	reference
cis-isoeugenyl acetate	1566	trace	weak clove note	tentative
caryophyllene alcohol	1571	0.1	woody spicy, terpene note	tentative
caryophyllene oxide	1583	0.4	spicy, green woody	reference
$\alpha$ -humulene epoxide	1607	0.1	woody, terpene note	tentative
trans-isoeugenyl acetate	1614	trace	weak clove-like	tentative

Reff: Jirovetz *et. al*, 2006

From the Table 1.1, there are 23 identified constituents in the clove oil and for *Eugenol*, 76.8% were identified as a major compound in the composition of clove oil.

The fine chemical industry works with high variety of chemical products with a high added value, which are changing continuously following market fluctuations and have a small lifetime. This implies that batch distillation must be flexible unit operation and must be able to separate the changing mixtures efficiently (Bonsfills and Puigjaner, 2004).

In order to fulfill demand in production of essential oil; in chemical engineering, process to extract valuable component in essential oil was improved to maintain the purity of essential oil. Crude essential oils are purified in batch distillation columns in order to enrich the product in some components while decreasing the amount of other components. Batch distillation is very efficient which allows the fractionation of multicomponent mixture into pure constituents in a batch distillation column. It is also used when there are large variables in feed composition or when production rates are varying. Batch distillation is also needed in production of small amounts of products with high value added especially in purification of essential oils. This has led to alternative configurations of batch distillation, including batch stripper, middle vessel column and multivessel column.

Middle Vessel Batch Distillation column was introduced to increase the capabilities of batch distillation column in purification process. Hasebe *et. al.* (1992) comes with the new idea; with the facts middle vessel is to overcome high energy demands and high temperature in feed vessel of regular batch distillation column. In regular batch distillation, the optimal operation of the process is strongly depends on the reflux policy and using of off-cuts. Besides, by using Middle Vessel Batch Distillation column, it is more efficient because the batch time for given heat input is shorter. So



that, with this found, Middle Vessel Batch Distillation can lead to lower temperatures in the feed vessel, energy and entrainer savings and easier handling of the liquid fractions involved in the process.

Middle Vessel Batch Distillation column operation is total reflux policy which is no reflux ratio used in the process. This column configuration has gained a lot of attention in the last few years. The presence of a middle vessel and of recycling streams to and from the column provides an extra degree of freedom for column operation (Barolo *et. al.*, 1996). In this column, the feed is charged to a vessel that is placed in the middle of the column. Products and impurities are taken off from both column ends. The total reflux operation is particularly advantageous because neither the yield nor the quality of the products is influenced by variations in the heating rate or interruption of the distillation; also, no product changeovers are required during the distillation, so that column operation is easier (Barolo *et. al.*, 1996). There are several parameters need to consider in control the optimum operation of batch distillation with middle vessel that still in research.

## **1.2 Problem Statement**

In regular batch distillation process, the feed vessel required high energy and high temperature of the column. In addition, high residence time of the column may lead to the decomposition of substances. Thus, middle vessel with total reflux policy operation is come out to improve the process of batch distillation. In the operation, vessel holdups and operating time are some of parameters need to consider that can affect the performance of column in separation process. Effects of vessel holdups and

operating time to the separation performance are obtained by varying those parameters during experiment.

### **1.3 Objective**

The objectives of this research are:

- To understand the separation performance of crude essential oil using middle vessel batch distillation column.
- To determine the vessels hold-up to the purification process using middle vessel batch distillation column.
- To determine operating time using middle vessel batch distillation column.

### **1.4 Scope**

In general, the scopes of the research include conducting various experiments to study the effects of vessel holdups and operating time to the Middle Vessel Batch Distillation.

In the Middle Vessel Batch distillation column, several parameters need to be considered in giving higher separation performance of the column. Vessel holdups and operating time are the parameters that will be studied in this research. Three vessel holdups will be varied to optimize the best performance of separation in the results of the experiments. Operating time for the process is determined by varying the time of the experiments.

## CHAPTER 2

### LITERATURE REVIEW

#### 2.1 Purification

Purification in terms of language is the process of rendering something pure or clean of foreign elements. In chemical context, purification is the physical separation of a chemical substance of interest from foreign or contaminating substances<sup>1</sup>. Methods in industry that are relevant to purify the chemicals substance are filtration, centrifugation, evaporation, extraction, crystallization, distillation and adsorption. Each process have own specifications to purify chemical substances. Performance of separation also depends on the process of purification. For example, distillation process is used to purify *Eugenol* in the Clove oil. Essential oil mixtures are often thermal sensitive materials, so that to avoid decompositions of the materials, batch distillation process is known used widely in industry over the past decade.

---

<sup>1</sup> <http://www.wikipedia.com/purification>

## 2.2 Essential Oil

Essential oil is an aromatic herbs or aromatic plants which are generally extracted by distillation. Essential oil is concentrated, hydrophobic liquid containing aroma compounds from plants. Essential oil is also known as volatile or ethereal oils, which is the oil of the plant materials from which essential oils were extracted such as oil of clove<sup>2</sup>. Plant materials are consisting of flowers, leaves, woods, barks, roots, seeds or peels.

Beside distillation as a process to extract essential oil from plant materials, there are expression and solvent extraction that are known widely in industry. In distillation process, raw plant materials are put into a distillation apparatus over water. As the water is heated, the steam passes through the plant materials and vaporizing the volatile compounds. The vapor will condensed into liquid through a coil of cooling water which then collected in receiving vessel. Other than that, expression process also used which is plant materials are expressed mechanically. However, this method is only suitable to the certain types of plant materials. It is due to the large quantities of oil in the plant materials. Meanwhile, solvent extraction is known used to extract the oil from plant materials. A solvent such as hexane or supercritical carbon dioxide is used to extract the oils. By lowering the extraction temperature, the solvent will separate the waxes from the essential oils. This lower temperature process prevents the decomposition and denaturing of compounds and provides superior products.

In history, in the different periods, various essential oils have been used medicinally. Essential oil is used in skin treatment to remedies for cancer. In recent decades, essential oil come out with popularity of aromatherapy, a branch of alternative

---

<sup>2</sup> [http://en.wikipedia.org/wiki/Essential\\_oil](http://en.wikipedia.org/wiki/Essential_oil)

medicine which claims that essential oils have medical properties that have been applied since ancient times and widely used until today.

### 2.2.1 Clove oil

*Syzygium aromaticum*, *Eugenia aromaticum* or *Eugenia caryophyllata* are synonyms to the cloves tree. In the family of Myrtaceae, the clove trees are grow in range 10-20 m of height with having oval leaves and crimson flowers. Firstly, flower buds have a pale color and become green gradually. When in bright red color, flower buds are ready for harvesting.



**Figure 2.1:** Clove buds and leaves

According to Food and Agriculture Organization (FAO), Indonesia produced almost 80% of the world's clove output in 2005 followed at a distance by Madagascar

and Tanzania<sup>3</sup>. In India, cloves called as *Lavang* that used in *Ayurveda* and mostly used for dental emergencies. The essential oil is used in aromatherapy when stimulation and warming is needed, especially in digestive problems. Application over the stomach or abdomen will warm the digestive tract.

Major component in the essential oil of clove is *Eugenol*. It is about 72% - 90% of *Eugenol* in the clove oil. *Eugenol* has well-defined antiseptic and anaesthetic properties<sup>4</sup>.

### 2.2.2 *Eugenol* and the Importance



*Eugenol* (C<sub>10</sub>H<sub>12</sub>O<sub>2</sub>) is an allyl chain-substituted guaiacol. *Eugenol* also known as 2-methoxy-4-allylphenol. In chemical compounds, *Eugenol* is a member of the allylbenzene class. The characteristics of *Eugenol* are clear to pale yellow oily liquid extracted from certain essential oils especially from clove oil. It is slightly soluble in water and soluble in organics solvents and has a pleasant, spicy, clove-like aroma. *Eugenol* is widely used in application of dentistry. When *Eugenol* mixed with zinc oxide, zinc oxide eugenol is formed which has restoration in dental medicinal. It is also used as a flavoring agent in food and cosmetic products and has pro-oxidant and antioxidant activities. The addition of antioxidants to food products earns increasing popularity as a powerful means for extending the shelf-life of products and for decreasing the nutritional losses by preventing or slowing the oxidation process (Jirovetz *et. al*, 2006). In Table 2.1 shows briefly the properties of *Eugenol* that exist in the plant materials and extracted by distillation or solvent extraction.

---

<sup>3</sup> <http://en.wikipedia.org/wiki/Clove>

<sup>4</sup> <http://en.wikipedia.org/wiki/Clove>

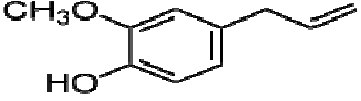
**Table 2.1:** Properties of *Eugenol*<sup>5</sup>

<b>Molecular structure</b>	2D 
	3D 
<b>IUPAC Name</b>	Eugenol
<b>Other names</b>	2-Methoxy-4-(2-propenyl)phenol Allylguaiacol 4-Allyl-2-methoxyphenol Eugenic acid Caryophylllic acid 1-Allyl-3-methoxy-4-hydroxybenzene 5-Allylguaiacol 2-Methoxy-4-allylphenol
<b>Molar mass</b>	164.20 g/mol
<b>Density</b>	1.06 g/cm <sup>3</sup>
<b>Melting point</b>	-9°C
<b>Boiling point</b>	256°C

<sup>5</sup><http://en.wikipedia.org/wiki/Eugenol>



### 2.2.3 Reaction of *Eugenol*

In reaction, *Eugenol* is converted to the ester by acetylation reaction and further process into vanillin by oxidation reaction. Briefly, there is how to obtain *Eugenol* by esterification reaction and oxidation reaction. In esterification reaction, alcohol is reacted with carboxylic acid to produce carboxylic ester. Ester can be produced by reflux of alcohol and acid carboxylic. Alcohols also function as solvent in this reaction. The esterification reaction is stated below:

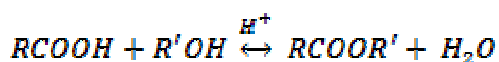

Oxidation reaction in organic chemistry is reduction of H atom or new bond is formed between C and H. There are two types of oxidation. First, oxidation of  $\pi$  bond without breaks the  $\sigma$  bond. Second is oxidation of  $\pi$  bond with breaks the  $\sigma$  bond. Oxidation without breaks the bond will produced epoxide or diol, meanwhile oxidation with break the bond will produced aldehyde and ketone of acid carboxylic. Commonly, reactants that used for alkene oxidation are  $KMnO_4$ ,  $OsO_4$ ,  $C_6H_5CO_3H$ ,  $CF_6CO_3H$  and  $O_3$ . In conclusion, oxidation of methyl iso-eugenol with  $KMnO_4$  is oxidation with breaks the  $\sigma$  bonds and followed by  $\pi$  bonds break that produced vanillin. Purity of *Eugenol* is analyzed using Gas Chromatography.

## 2.3 Batch Distillation in Theory

Distillation is a method of separating chemical substances based on differences in their volatilities in a mixture. Distillation usually forms part of a larger chemical process, and is thus referred to as a unit operation. Commercially, distillation has a number of uses. It is used to separate crude oil into more fractions for specific uses such as transport, power generation and heating. Water is distilled to remove impurities, such as salt from sea water. Air is distilled to separate its components such as oxygen for medical applications and helium for balloons. The use of distillation on fermented solutions to produce distilled beverages with higher alcohol content is perhaps the oldest form of distillation, known since ancient times. Distillations of essential oil usually use batch distillation method significantly batch distillation is a very efficient unit operation which allows the fractionation of multi-component mixture into its pure constituents in a single column.

In the last few years, batch distillation has received increasing attention because of its simplicity of operation, flexibility and lower capital cost rather than continuous distillation. Batch distillation is a single column that can separate many different components from a multi-component feed of multiple cuts with different product specification from binary feed. The use of batch distillation is becoming increasingly important for the separation and purification of high-value chemicals in many chemicals, food and pharmaceutical processes (Barolo, *et .al*, 1996). In batch distillation, a mixture is distilled repeatedly to separate it into its component fractions before the distillation still is again charged with more mixture. Contrast with continuous distillation, the feedstock is added and the distillate is drawn off without interruption. Batch distillation has always been an important part of the production of seasonal or low capacity and high-purity chemicals.

According to Barolo *et. al*, 1996, traditionally, the most popular kind of batch column is the so-called 'regular' or rectifying column, which is made up of a larger boiler, to which all the feed is charged and of a rectifying section from whose top cuts of

different compositions are removed. The batch rectifier consists of a pot, rectifying column, a condenser, some means of splitting off a portion of the condensed vapor or distillate as reflux, and one or more receivers. The pot is filled with liquid mixture and heated. Vapor flows upwards in the rectifying column and condenses at the top. Usually, the entire condensate is initially returned to the column as reflux. This contacting of vapor and liquid considerably improves the separation. Generally, this step is named start-up. After some time, a part of the overhead condensate is withdrawn continuously as distillate and it is accumulated in the receivers, and the other part is recycled into the column as reflux. Figure 2.2, shows the basic of batch rectifier exist in the batch distillation process.

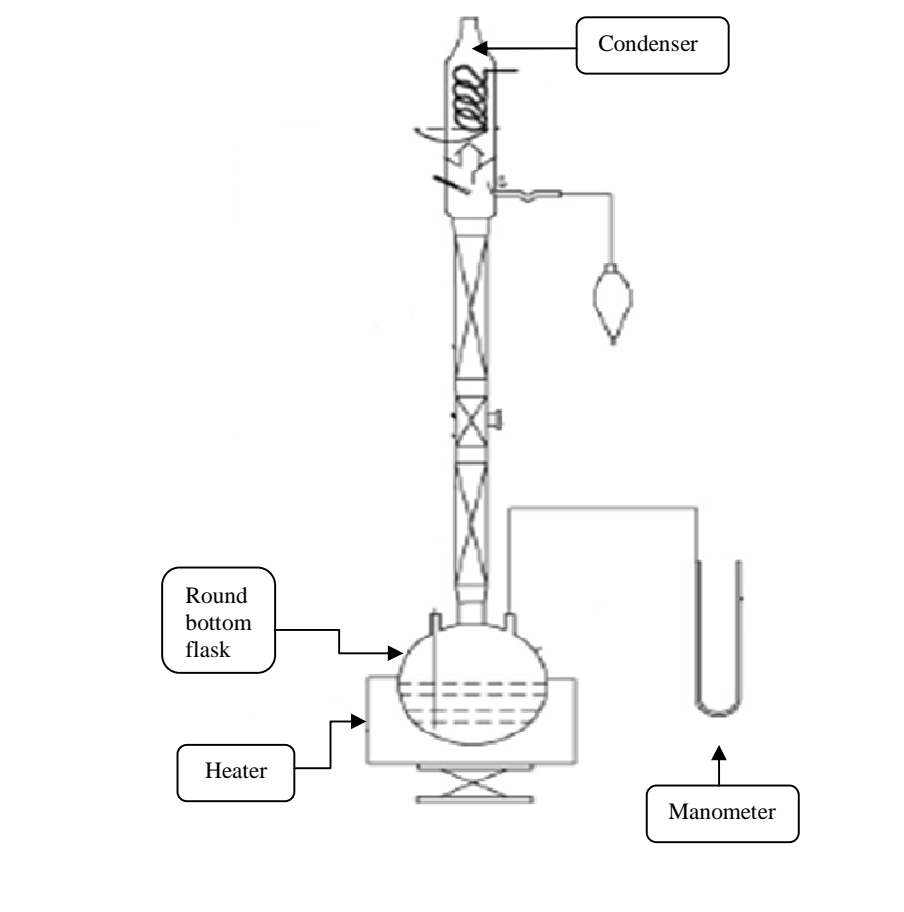
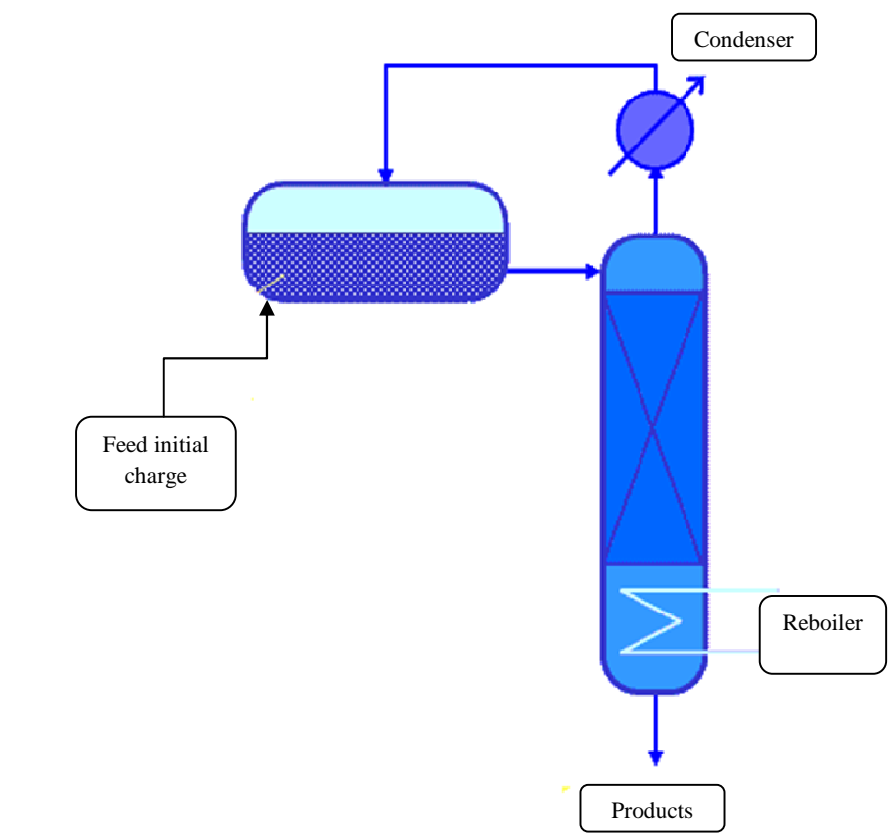

**Figure 2.2:** Batch rectifier

Less frequently, an “inverted” or “stripping” batch column is preferred, for example when the amount of the light component in the feed charge is small and the products are to be recovered at high purity (Sorensen and Skogestad, 1995). In this column, the feed is charged to the top vessel and the products are withdrawn from the bottom, so that a smaller reboiler can be used (Barolo, *et. al*, 1996). Stripper is inverted column from the batch rectifier. During operation, after charging the pot and starting up the system, the high boiling constituents are primarily separated from the charge mixture. The liquid in the pot is depleted in the high boiling constituents, and enriched in low boiling ones. The high boiling product is routed into the bottom product receivers.

The residual low boiling product is withdrawn from the charge pot. This mode of batch distillation is very seldom applied in industrial processes. Figure 2.3 shows the model of batch stripper that exists.

Recently several alternative column configurations have been developed, which primarily differ in the position of the major liquid holdup in the column leading to, the middle vessel and multi-vessel column configurations. All of alternatives make improvements on the basis of conventional batch distillation column. Although good separation results can be gained, capital cost is increased to retrofit the conventional column.



**Figure 2.3:** Batch stripper

## 2.4 Middle Vessel Batch Distillation

From the study of Middle Vessel Batch Distillation previously, it shows the advantages with this type of distillation. It can lead to lower temperature in the feed vessel, to energy and entrainer savings and to an easier handling of the liquid fractions

involved in the process (M. Warter, 2001). Middle Vessel Batch Distillation column is a combination of a regular and an inverted batch distillation and was originally proposed by Robinson and Gilliland (1950). The column is divided into a rectifying and a stripping section by the feed vessel which is connected to the middle of the column. With this type of process it is possible to obtain simultaneously light and heavy boiling fraction accumulates in the middle vessel. In addition, middle vessel column can be equipped with a smaller reboiler compared to that of a regular batch column (Barolo, *et al.*, 1996). With the total reflux operation, there are two degrees of freedom which are holdups and product flows as degree of freedom. There are no influenced by heating rate and also there are no product changeovers are required during the distillation, so that the column operation is easier. In Figure 2.4, it shows the principle structure of a middle vessel batch distillation.

In the Middle Vessel Batch Distillation column, several components are important in the column to function efficiently. Stages in middle vessel batch distillation column have function in varying feed systems and different separation tasks. The number of the stages gives same influence on the energy demand of a separation as in any other distillation process i.e. with increasing number of stages the energy demand decreases (M. Warter *et al.*, 2002).

The location of the withdrawal and reflux to and from the middle vessel has a big influence on the energy demand (M. Warter *et al.*, 2002). The separation that carried out in the upper column section is consuming and determines the energy demand

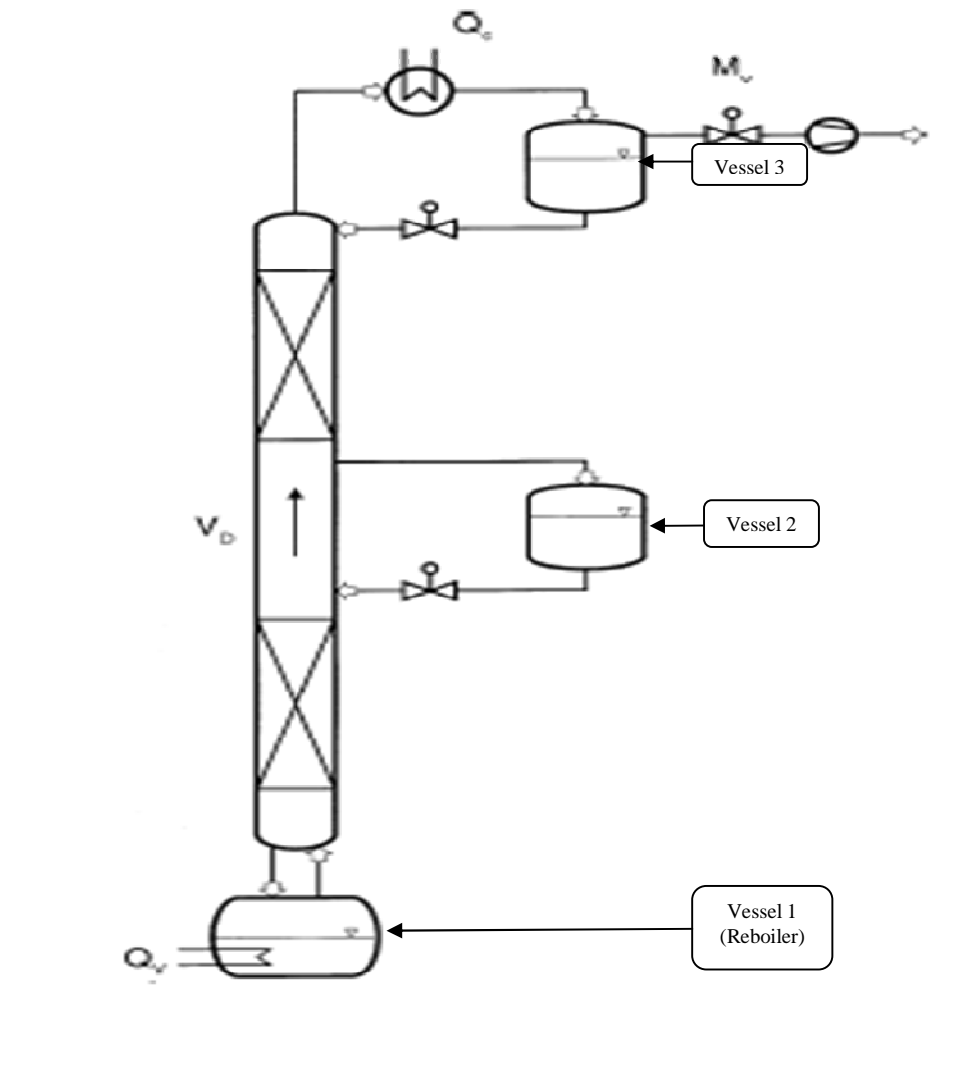

**Figure 2.4:** Principle structure of a middle vessel batch distillation

(M. Warter *et. al*, 2002). The separation that carried out in the upper column section is consuming and determines the energy demand of the whole process. Vice versa, for a very low location of the withdrawal the separation carried out in the lower column sections determines the total energy demand.



Heat exchanger in withdrawal and reflux line of the middle vessel gives the role to the column to keep the temperature of the charge in the middle vessel as low as possible. Hence, it will avoid the decomposition of critical substances. In the heat exchanger, the heat will exchange between the hot stream leaving the column and the cold reflux line from the middle vessel. In this way, the stream leaving the column is cooled down before entering the middle vessel keep at low temperature in the vessel.

Reboiler in the middle vessel batch distillation column generates a vapour stream entering the upper column section. The flow rate of this stream can be manipulated to 'steer' the concentration in the middle vessel (M. Warter *et. al*, 2002). There exist different modifications of the column section connected to the withdrawal and reflux line of the middle vessel. This modification of the column can lead from a thermodynamic point of view, to energy savings in a batchwise extractive distillation (M. Warter *et. al*, 1999).

#### **2.4.1 Advantages of Middle Vessel Batch Distillation Operation**

In the batch distillation process, the feed is exposed from the beginning to high temperatures. This situation can be harmful for substances which tend to decompose. In middle vessel batch distillation, only the fraction of feed charged to the sump is heated up to the bubble point temperature at the beginning, while normally big part in the middle vessel is just exposed to ambient temperature. Rather to regular batch distillation, temperature is increasing lower and the temperature never reaches the boiling point temperature of the high boiler.

In the regular batch process the product is kept in the reboiler as long as the low boiling impurities are removed from top of the column. In the middle vessel batch distillation process, only the amount of product which is in the sump gets in contact with the reboiler surface.

The smaller amounts of liquid in the reboiler of a middle vessel column lead to advantages in the start-up of the column. While in a regular batch distillation process the total amount of feed is heated up to the boiling point at the start-up of the process, it is just small amount when using a batch distillation with a middle vessel. In addition, the process of middle vessel proved to save time because there is separation stages performed simultaneously.

#### **2.4.2 Total Reflux Policy Operation**

Bortolini and Guarise (1971) was suggested total reflux operation for a conventional batch distillation column. (Wittgens, B.*et al*, 1996). The simplest operation strategy is with only one cycle, that is, the column is operated under total reflux and the final products are collected in the condenser drum and in the reboiler. They also suggested using a middle vessel where the feed is charged to the middle of the column. In 1995, Hasebe comes with a multivessel column with total reflux that can separate more than two components. The policies can be implemented in the multivessel batch distillation column with both holdups and product flows as degrees of freedom. The simplest operation form of total reflux operation is that suggested by Hasebe (1995) where the product rates are set to zero ( $D_i = 0$ ). In this operation, it is simpler since no product changeovers are required during operation. In addition, the energy requirement is less where the heat is required for the separation is supplied to the reboiler and cooling

is done only at the top. The advantage of cyclic operation to the middle vessel compared to regular batch column, the process gives rise to no off-cuts if separation efficiency is high enough. In total reflux operation, theoretically, the bottom vessel of every column and reflux drum is filled with the raw material and the heat supplied to the bottom vessel (reboiler) of the first column. The vapor from the top of a column is supplied to the bottom of the next column, and the liquid in the bottom vessel is returned to the top of the previous column. By continuing total reflux operation, the  $i$ th heaviest component is accumulated in the vessel of the column  $i$ . The operation is terminated when the compositions of all vessels satisfy the product specification (Hasebe, *et. al*, 1999). Operation at total reflux can be profitable when it is required to recover the mixture components at very high degree of purity. In addition, the operation is simple because there is no product changeovers are necessary (Barolo, *et. al*, 1996).

## 2.5 Vessel holdup and Operating time

Vessel holdup and operating time are two of the parameters that considered in this study. There are three vessel holdups at middle vessel and top vessel. In adjusting the desired qualities, Hasebe *et. al*, (1997) suggested controlling the mass holdup in the product vessel directly. It is advantageous to vary the holdups, instead of keeping constant by calculating the steady state value in advance. According to Barolo, *et.al*, (1998), the optimal or minimum batch distillation time is strongly dependent on the ratio of  $F^{\text{in}} / V'$  for  $F^{\text{in}} \leq V'$  but it is weakly dependent on such a ratio for  $F^{\text{in}} > V'$ . By simulation and experimentally, the increasing of feed or withdrawal rates indeed decreases the batch distillation time.

## 2.6 Gas Chromatography

Gas chromatography is a chromatographic technique that can be used to separate volatile organic compounds. The separations of organic compounds are due to the differences in partitioning behavior between the mobile gas phase and the stationary phase in the column. Normally, a gas chromatography consists of a flowing mobile phase, an injection port, a separation column containing stationary phase, a detector and a data recording system. The schematic diagram of the basic gas chromatography is shown in Figure 2.5.

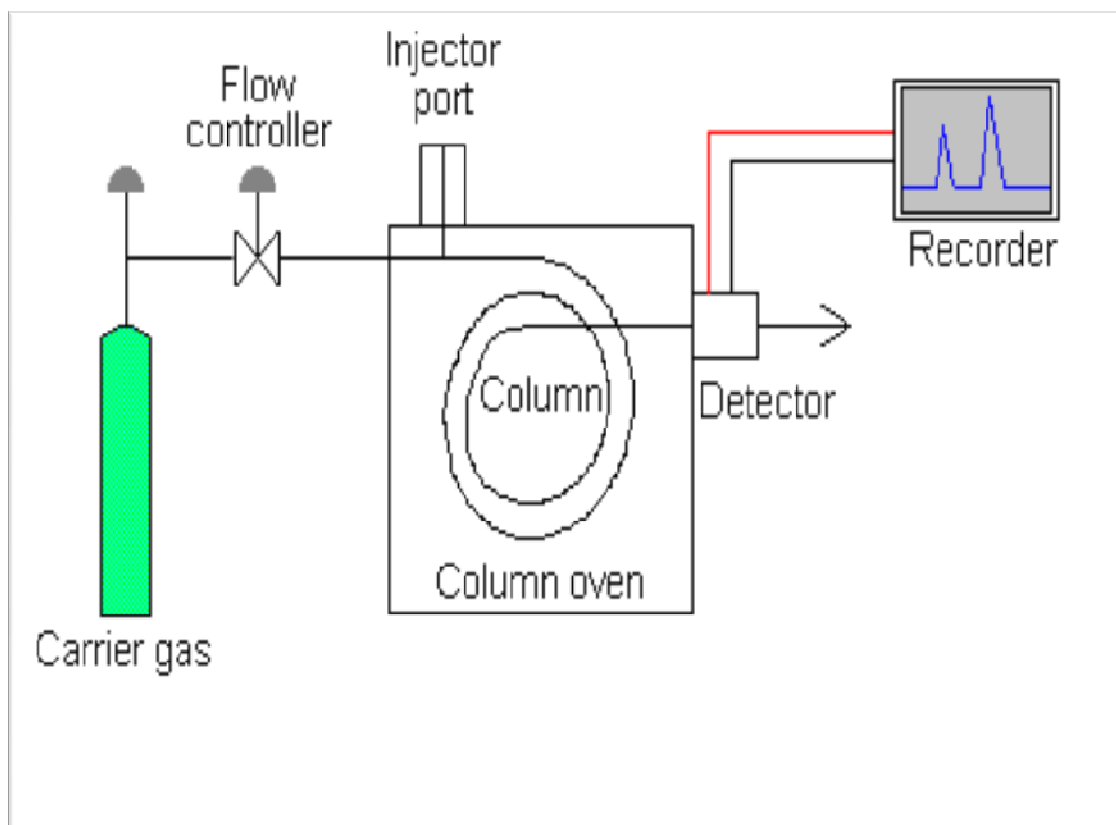

**Figure 2.5:** A schematic diagram of basic gas chromatography

Generally, mobile phases that used in gas chromatography are inert gases for instance helium, argon or nitrogen. The injection port consists of a rubber septum through which a syringe needle is inserted to inject the sample. The injection port is maintained at higher temperature than the boiling point of the least volatile component in the sample mixture. The separation column is usually contained in thermostat-controlled oven because of the partitioning behavior is dependent on temperature. Separating components with a wide range of boiling points is accomplished by starting at low oven temperature and increasing the temperature over time to elute the high-boiling point components. Most columns contain a liquid stationary gas phase on a solids support. Separation of low-molecular weight gases is accomplished with solid adsorbents.

## **CHAPTER 3**

### **METHODOLOGY**

#### **3.1 Material**

In order to understand the behavior of separation performance for the operation process Middle Vessel Batch Distillation, experiments will be conducted during period of this research. Raw materials for the experiments are crude clove oil. From the crude, it is purified by using batch distillation with middle vessel column. Crude clove oil is in the liquid phase and black in colour. It is obtained from extraction process. Extraction process is not conducted due to beyond the scope of this research. Therefore, it was purchased from Indonesia. Before starting the experiment, crude clove is filtered to avoid muck at the vessel after heating.