

Study of the Surface Integrity of AISI 4140 Steel in Wire Electrical Discharge Machining

M. A. Hassan, N. S. Mehat, S. Sharif, R. Daud, S. H. Tomadi, M. S. Reza, *Member, IAENG*

Abstract—The Wire Electro Discharge Machining (WEDM) process is a violent thermal process where literally thousands of electrical discharges are produced in a fraction of a second in order to erode a certain volume of metal. The process is most used in situations where intricate complex shapes need to be machined in very hard materials (such as hardened tool steel). However, the process generates surface that have poor properties such as high tensile residual stresses, high surface roughness, presence of micro-cracks and micro-voids. These properties vary with different levels of the main machining parameters. The aim of this paper is to present experimental work that has been done in order to quantify the effect of some of the main WEDM parameters on the surface texture of AISI 4140 steel. 2D surface measurements were taken on all WEDM samples and 2D surface characterization has been carried out in order to calculate the different surface texture parameters. In this work, the surface characteristics caused by WEDM were analyzed by Scanning Electron Microscopy (SEM).

Index Terms—AISI 4140 steel, Scanning Electron Microscopy, surface texture, Wire Electro Discharge Machining.

I. INTRODUCTION

Wire Electro Discharge Machining (WEDM) is one of the applications of EDM. This machine is generally uses a thin brass wire as the electrode, making it possible to cut most shapes and contour from flat plate material. WEDM can do things older technologies cannot do as well, as quickly as, as inexpensively, and as accurately. Most parts can now be programmed and produced as a solid, rather than in sections and then assembled as a unit, as was necessary previously. WEDM is capable of producing complex shapes such as tapers, involutes, parabolas and ellipses. WEDM utilizes a thin, continuously moving wire as an electrode. The wire electrode is drawn from a supply reel and collected on a take-up reel. This continuously delivers fresh wire to the work area. The wire is guided by sapphire or diamond guides and kept straight by high tension, which is important to avoid tapering of the cut surface. High-frequency dc pulses are

delivered to wire and workpiece, causing spark discharges in the narrow gap between the two. A stream of dielectric fluid is directed, usually coaxially with the wire, to flood the gap between the wire and the workpiece. The power supply for the WEDM are essentially the same as for conventional EDM, except the current carrying capacity of the wire limits currents to less than 20A, with 10A or less being most normal. In addition, the spark frequencies are higher, up to 1MHz, to give a fine surface on the workpiece [1, 2].

II. LITERATURE REVIEW

A. Wire Electro Discharge Machining

Wire Electro-discharge Machining (WEDM) is an adaptation of the basic EDM process, which can be used for cutting complex two- and three-dimensional shapes through electrically conducting materials. WEDM utilizes a thin, continuously moving wire as an electrode referring to Fig. 1. It is a relatively new process and applications have grown rapidly particularly in the tool making field. The wire electrode is drawn from a supply reel and collected on a take-up reel. This continuously delivers fresh wire to the work area. The wire is guided by sapphire or diamond guides and kept straight by high tension, which is important to avoid tapering of the cut surface [14]. High-frequency dc pulses are delivered to the wire and workpiece, causing spark discharges in the narrow gap between the two. A stream of dielectric fluid is directed, usually coaxially with the wire, to flood the gap between the wire and the workpiece. The power supplies for the WEDM are essentially the same as for conventional EDM, except the current carrying capacity of the wire limits current to less than 20 A, with 10 A or less being most normal. In addition, the spark frequencies are higher up to 1 MHz, to give a fine surface finish on the workpiece [6]. The workpiece is moved under computer numerical control (CNC) relative to the wire, and this enables complex-shaped profiles to be cut through sheet and plate materials. Many machines incorporate further angular positioning of the wire, thus, allowing varying degrees of taper on the cut surface to be obtained. Adaptive control, based on gap-voltage sensing, is necessary to avoid contact between the wire and the work material. Short circuits must be sensed and the wire backed off along the programmed path to reestablish the correct gap for efficient cutting [2, 3].

Manuscript received February 6, 2009. The authors would like to express their appreciation to the Research Management Centre (RMC) of UMP and Faculty of Mechanical Engineering for their financial support for the above project.

M. A. Hassan is with the Universiti Malaysia Pahang, Faculty of Mechanical Engineering, Highway Tun Razak, 26300 Gambang, Pahang, Malaysia. (corresponding author phone: 09-5492205; fax: 09-5492244; e-mail: masszee@ump.edu.my).

S. Sharif is with the Department of Manufacturing and Industrial Engineering, Faculty of Mechanical Engineering, Universiti Teknologi Malaysia, Skudai, Johor, Malaysia. (e-mail: safian@fkm.utm.my).

N. S. Mehat, R. Daud, S. H. Tomadi and M. S. Reza are with the same university as the corresponding author.

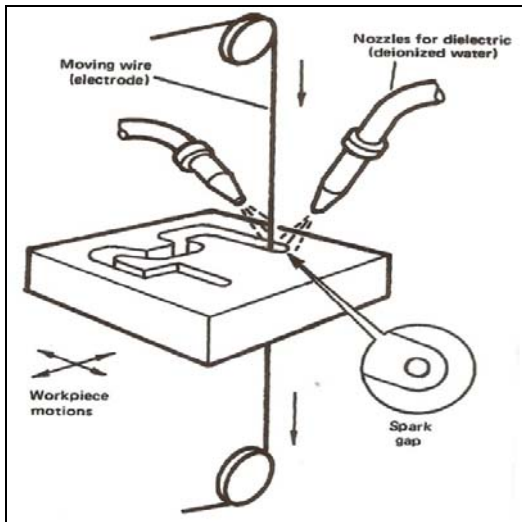

Fig. 1: The basic features of WEDM.

B. Machining parameters

Metal removal rates (MRR), surface finish and accuracy are influenced mainly by the choice of electrical parameters. As the current is increased each individual spark removes a larger crater of workpiece material, which increases the metal removal rate but also increases the surface roughness. Similar effects occur with increased spark voltage. Increasing the spark frequency, while keeping the other parameters constant, results in a decrease in surface roughness, because the energy available is shared between more sparks, and smaller-sized surface craters are produced in the workpiece. The frequency range of modern WEDM machines is from 180 Hz, for roughing cuts, to several hundred kilohertz, for fine finishing. When the sparking frequency becomes very high, the dielectric fluid cannot de-ionize at a sufficiently high rate, placing an upper limit on the frequencies possible. Volumetric removal rates vary from 0.001 to 0.1 cm³/hr [15]. As shown in Fig. 2, the spark cycle, T , is the period of the spark, including both on time and off time. EDM uses a DC power supply and capacitor like energy storage bank to create the discharge. During the off time, T_{on} , the capacitors are charged up and melted material is flushed from the gap between the wire electrode and workpiece. Then the circuit is completed, the spark is discharged and the energy is delivered during the on time, T_{on} , which is the spark on-time. This total time for charging and discharging is the spark cycle. This research studies the effect of T_{on} and T_{off}/T on EDM MRR. The gap voltage is the nominal voltage in the gap between the wire and workpiece [9,10].

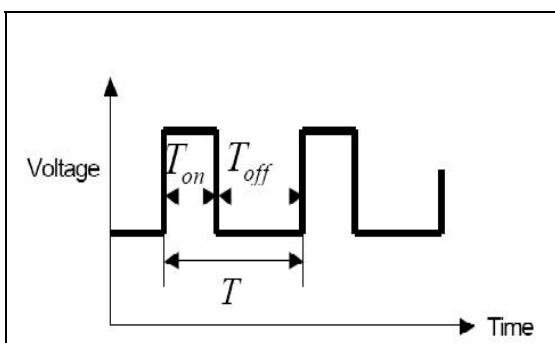

Fig. 2: Voltage vs duration during WEDM cutting process.

C. Material of the wire and workpiece

The brass wire is used in the experiment based on the mechanical properties which is very suitable to use as the wire material in WEDM. The range of the wire diameter is 0.1 to 0.33 mm and has two types which are hard brass wire and soft brass wire. In this project, the hard brass wire has been chosen due to its properties. It has tensile strength of 1030 N/mm² and elongation less than three percent. Furthermore, the breaking load is in between 3.14 kg to 3.30 kg which is quite high compare to the other types of material [17]. This AISI 4140 Steel also known as chromium molybdenum alloy steel is oil hardening steel of relatively high hardening ability and is among the most widely used versatile machinery steels. The chromium content provides good hardness penetration and the molybdenum imparts uniformity of hardness and high strength. This grade is especially suitable for forging as it has self scaling characteristics it responds readily to heat treatment and is comparatively easy to machine in the heat treated condition. In the heat treated condition tensile strengths are attended all combined with good ductility and resistance to shock [15].

III. METHODOLOGY

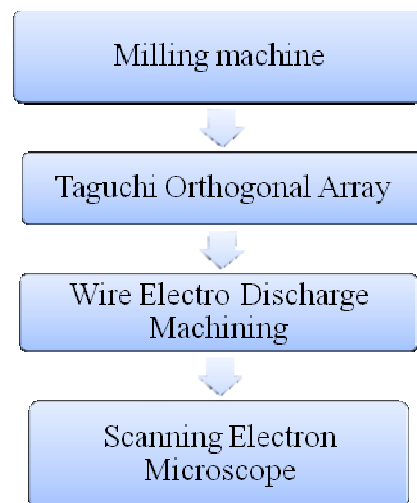

Fig. 3: Flow chart for the whole experiments.

Fig. 3 explained about the steps of experiment that has been done in this project. Milling machine is used to smooth the surface of the specimen before it can be proceed to the WEDM cutting process. Taguchi Orthogonal Array is used to design the experiment that should be run during WEDM process. There are nine experiments to be done. After that, the workpiece is cut using WEDM with different machining parameters. As soon as the workpiece has been cut, the specimen is examined using SEM to see the surface textures.

A. Milling machine

The milling machine was used to smooth the surface of the workpiece before it can be proceed with the experiment. Furthermore, the dimension of the workpiece can be set accurately to make it easy to clamp on the WEDM. Besides that, it can avoid error in the readings when the experiments have been done. Milling is the process of cutting away

material by feeding a workpiece past a rotating multiple tooth cutter. In face milling, the cutter is mounted on a spindle having an axis of rotation perpendicular to the workpiece surface. The milled surface results from the action of cutting edges located on the periphery and face of the cutter [12].

B. Taguchi Orthogonal Array

The Taguchi's Robust Design was used for the design of the experiment. Three levels of each factor were chosen, L9 orthogonal array was designed for the experiment. Table I show three levels of each variable were used in the experiment while Table II shows the machining condition for the 9 experiments designed by L9 Taguchi Orthogonal Array [21]

Table I: Level of independent variables in WEDM experiment.

Level	Pulsed current (A)	Pulse-on duration (μ s)
1	1.5	3.2
2	5.0	6.4
3	12.5	12.0

Table II: L9 Orthogonal Array for the WEDM experiment.

Experiment no.	Pulse-on duration, I_p (A)	Pulsed current, T_{on} (μ s)
1	1.5	3.2
2	1.5	6.4
3	1.5	12.0
4	5.0	3.2
5	5.0	6.4
6	5.0	12.0
7	12.5	3.2
8	12.5	6.4
9	12.5	12.0

C. WEDM cutting process

The WEDM experiments were performed on a WEDM machine model type Sodick 200. A number of process variables can be investigated during the WEDM process. Following some of the findings of preliminary experiments and also based on literature survey, only two independent variables, namely, pulsed current and pulse-on duration, were varied, both of which were settings of the power supply. The experiments were conducted in de-ionized water by immersing the workpiece to a depth of 35 mm. A thin brass wire of 0.20 mm in diameter was used as tool for cutting the workpiece. The brass wire served as the negative polarity and the specimen served as the positive polarity during the WEDM process. The specimen was cut from a rectangular bar of AISI 4140 steel with dimension 200 x 40 x 15 mm using WEDM cutting process. Table III shows the wire electro-discharge machining conditions. The machining voltage was maintained at 80 V, off-time duration at 100 μ s

and flushing pressure at 0.1 MPa. The other two parameters were maintained at three levels; current setting at 1.5, 5.0 and 12.5 A; and on-time duration at 3.2, 6.4 and 12.0 μ s. For every trial of the nine experiments, a specimen was prepared by cutting 10 mm length of workpiece using the WEDM process. During the WEDM process, the pulse-off duration setting 10 μ s could effectively control the flushing of the debris from the gap, offering machining stability. Hence, the effect of the pulse-off duration on the machined characteristics was not considered in the present work.

Table III: Experimental conditions for WEDM.

Dielectric	de-ionized water
Work material	AISI 4140 Steel
Wire material	brass (0.20 mm)
Pulse-off duration	10 μ s
Voltage	80 V
Wire speed	15 mm/min
Flushing pressure	0.1 MPa
Pulsed current	1.5, 5.0, 12.5 A
Pulse-on duration	3.2, 6.4, 12.0 μ s

D. Scanning Electron Microscopy

Sample 40 x 40 mm² strip is generally mounted rigidly on the specimen holder called a specimen stub. The sample is placed in a small chamber which is at vacuum column through an air-tight door. Before that, all water, solvents or other materials that could vaporize while in the vacuum must be removed. When a SEM is used, the column must always be at vacuum. There are many reasons for this. If the sample in a gas filled environment, an electron beam cannot be generated or maintained because of a high instability in the beam. The final image is built up from the number of electrons emitted from each spot on the sample [11].

IV. RESULTS AND DISCUSSION

A. Surface morphology

Surface morphology plays an important part in understanding the characteristics of machined surfaces. During WEDM process, the discharged energy produces very high temperatures at the point of the spark, causing a minute part of the specimen to melt and vaporize. With each discharge, a crater is formed on the machined surface. The surface morphology is a function of two parameters, pulsed current and pulse-on duration, both of which are settings of the power supply. SEM was conducted in order to evaluate the effect of machining parameters on the surface textures of the AISI 4140 steel. Fig. 4 and 5 below shows the two-dimensional SEM image of the machined surface obtained from the WEDM specimens. The darker contrast corresponds to the lower areas of surface and the brighter corresponds to the higher. It is clear that the morphology of the WEDM surface was dependent on the applied pulsed current and pulse-on duration. Moreover, The WEDM surfaces abound with the craters and ridged surfaces. The

craters and ridge-rich surfaces were formed by melted material, which was blasted out of the surface by the discharge pressure and subsequently quickly reached solidification temperature through being cooled by the surrounding working fluid. When a smaller pulsed current and pulse-on duration were applied, the surface characteristics had minor hillocks and valleys. When the pulsed current and pulse-on duration increased, the machined surface exhibited deeper craters and ridge-rich surfaces. Previous work has observed a similar phenomenon [11]. This phenomenon might be attributable to a higher pulsed current and a longer pulse-on duration causing more frequent cracking of the dielectric fluid, as there was more frequent melt expulsion leading to the formation of deeper and larger craters on the surface of the workpiece.

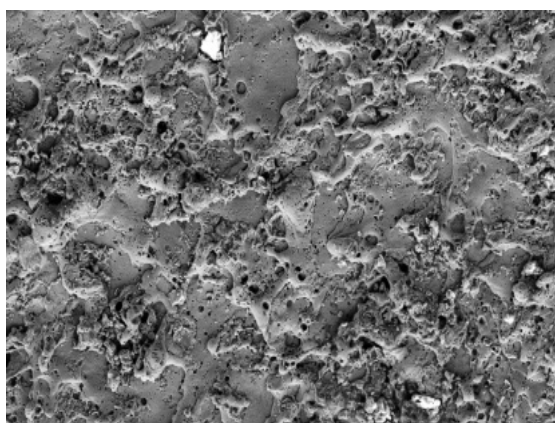

Fig. 4: SEM micrograph on smaller Ra of AISI 4140 steel under EDM conditions: pulse on, $I_{on} = 1.5A$ and pulsed current, $T_{on} = 3.2 \mu s$.

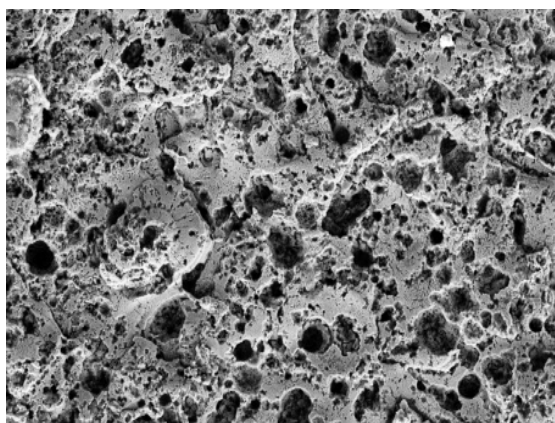

Fig. 5: SEM micrograph on larger Ra of AISI 4140 steel under EDM conditions: pulse on, $I_{on} = 12.5A$ and pulsed current, $T_{on} = 12 \mu s$.

B. Surface roughness

Surface roughness is a critical parameter for evaluating machined quality. In order to determine the effect of the WEDM process on the surface roughness of the AISI 4140 steel, the surface profiles of the WEDM specimens were measured by perthometer and SEM. The value of the surface roughness, R_a , of the machined specimen was calculated according to Eq. (1)

$$Ra = 21.00(I_p)0.33(\tau_{on})1.37 \quad (1)$$

where R_a is the surface roughness, I_p denotes the pulsed current and T_{on} represents the pulse-on duration. The surface roughness on the machined surface varied from 118.14 to 1454.38 nm (Table IV). From these results it is obvious that a higher pulsed current and longer pulse-on duration caused a poorer surface finish. Fig. 6 shows that graph surface roughness at various machining conditions. It was found that an excellent machined finish can be obtained by setting the machine parameters at low pulsed current and small pulse-on duration. This can be attributed to the fact that as the pulsed current decreases, discharges strike the surface of the sample less intensely, and the resulting better erosion effect leads to smoother surface. Furthermore, as the pulse-on duration decreases, the amount of heat energy transferred to the sample surface decreases, and so less material melts. The fact that the surface roughness decreases with decreasing discharge energy has been described in the literature [10, 11,12].

Table IV: Result of surface roughness for nine specimens.

Experiment no.	Pulse-on duration, I_p (A)	Pulsed current, T_{on} (μs)	Surface roughness, R_a (nm)
1	1.5	3.2	118.14
2	1.5	6.4	305.35
3	1.5	12.0	722.45
4	5.0	3.2	175.77
5	5.0	6.4	368.54
6	5.0	12.0	1074.87
7	12.5	3.2	237.82
8	12.5	6.4	614.70
9	12.5	12.0	1454.38

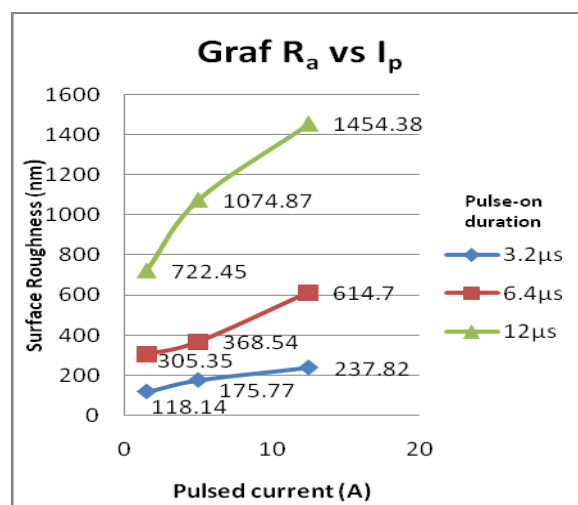

Fig. 6: Effect of pulse on workpiece surface roughness.

C. Micro-cracks

The WEDM-cut surface is covered with cracks and micro-cracks. The depth of the cracks terminates within the white layer. Cracks and micro-cracks in the WEDM specimens are undesirable as they reduce the service strength of the machined component. The micro-cracks were associated with the development of thermal stresses exceeding the ultimate tensile strength of the material. The primary causes of the thermal stress in the machined surface were the drastic heating and cooling rates and the non-uniform temperature distribution. Fig. 7 shows the dependence of the maximum depth of micro-cracks on the WEDM parameters. The figure shows that the depth of the micro-cracks on the WEDM specimen ranged from 648.33 to 1594.45 nm, increasing with the pulsed current and pulse-on duration. The correlation between the maximum depth of the micro-cracks, C_{max} , and the machining conditions was calculated according to Eq (2):

$$C_{max} = 393.30 (I_p)^{0.20} (T_{on})^{0.36} \quad (2)$$

Table V: Result of depth of micro-cracks for nine specimens.

Experiment no.	Pulse-on duration, I_p (A)	Pulsed current, T_{on} (μ s)	Depth of micro-cracks, V_{max} (nm)
1	1.5	3.2	840.52
2	1.5	6.4	1999.11
3	1.5	12.0	4386.19
4	5.0	3.2	1591.01
5	5.0	6.4	3784.09
6	5.0	12.0	8302.58
7	12.5	3.2	2585.73
8	12.5	6.4	6149.93
9	12.5	12.0	13493.40

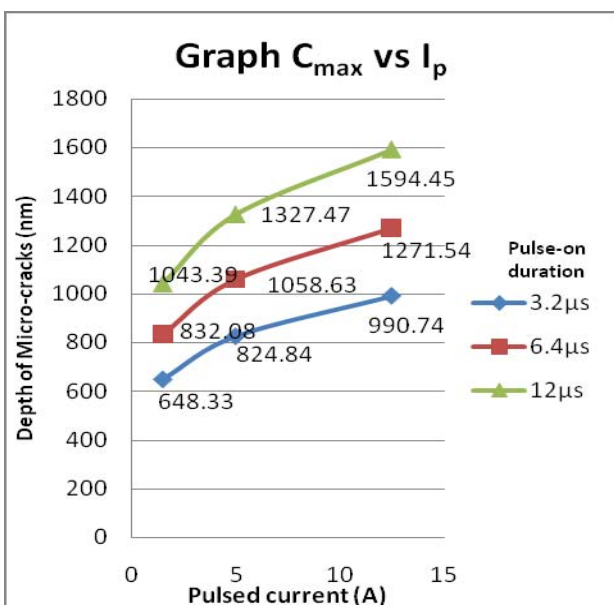

Fig. 7: Effect of pulse-on on the depth of micro-cracks.

D. Micro-voids

The maximum depth of micro-voids of 840.52 to 13493.4 nm was found on the WEDM surface (Table VI). The depth of voids clearly increased with the increase in energy supply. This is because of the fact that heat supplied to the workpiece due to sparks is higher at larger pulsed current and pulse-on duration, and hence increased the voids degree. Using eq. (3) to determine the correlation between the maximum depth of the micro-voids, V_{max} , and the machining parameters:

$$V_{max} = 158.41 (I_p)^{0.53} (T_{on})^{1.25} \quad (3)$$

This semi-empirical model indicates that the pulse-on duration has more dominant effect on the maximum depth of the micro-voids compared to the pulsed current. Comparing the results of Fig. 7 and 8, it was found that the depth of the micro-voids was greater than the depth of the micro-cracks.

Table VI: Result of depth of micro-voids for nine specimens.

Experiment no.	Pulse-on duration, I_p (A)	Pulsed current, T_{on} (μ s)	Depth of micro-cracks, C_{max} (nm)
1	1.5	3.2	648.33
2	1.5	6.4	832.08
3	1.5	12.0	1043.39
4	5.0	3.2	824.84
5	5.0	6.4	1058.63
6	5.0	12.0	1327.47
7	12.5	3.2	990.74
8	12.5	6.4	1271.54
9	12.5	12.0	1594.45

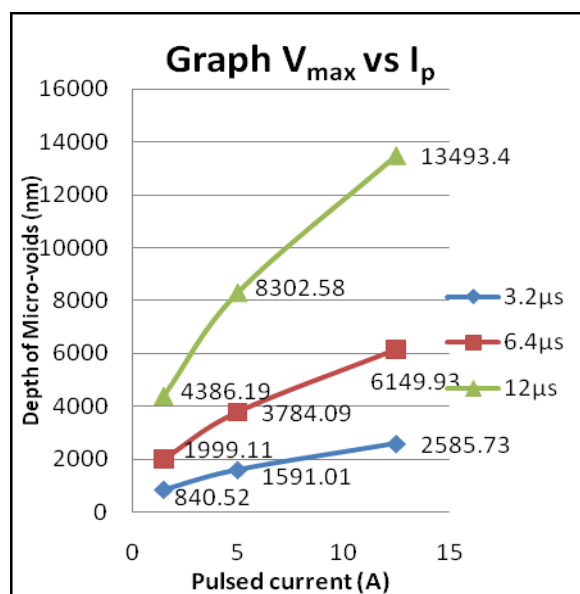

Fig. 8: Effect of pulse-on on the depth of micro-voids.

V. CONCLUSIONS

In this project, the relative importance of two main machining parameter variables in WEDM has been identified. Based on the obtained findings, the SEM can be successfully applied to obtain a two-dimensional image with a nanometer scale. The surface roughness of the machined surface can be determined by examine the specimen using pethometer recorder. AISI 4140 steel was cut into nine specimens with different machining parameters which are pulsed current and pulse-on duration. From the data collected and analyzed, it can be concluded that the pulse-on duration has major influence in defining the WEDM surface texture as compared to the pulsed current. Moreover, the interaction effect between pulsed current and pulse-on duration on the 2D surface roughness parameters is relatively small. Through analysis on SEM and calculation, it has been observed that the value of surface roughness, depth of micro-cracks and micro-voids slightly increased with time taken. The higher discharge energy caused more frequent melting expulsion, leading to the formation of a deeper and larger crater on the surface of the workpiece, and resulted in a poorer surface finish. Based on the obtained formula, the values of surface roughness, depth of micro-cracks and micro-voids produced by the WEDM could be evaluated. Moreover, the effect of the magnitude of the pulse-on duration on the surface texture of the specimen was more dominant than the pulsed current.

Overall, there are a few steps that can be done more details to produce a good surface finish such as the WEDM machining parameters should be set at low pulsed-current and small pulse-on duration. Once the specimens have been cut, it must be examined instantly to avoid corrosion at the surface which is leads to the bad surface finish. Besides that, the perthometer recorder should be use gently so that the readings can be obtained accurately due to its high sensitivity.

ACKNOWLEDGMENT

The authors would like to express their appreciation to the Research Management Centre (RMC) of UMP and Faculty of Mechanical Engineering for their financial support for the above project. The authors also are very grateful to all the staffs in UMP and UTM who involved in this project directly or indirectly.

REFERENCES

- [1] Y. H. Guu, and M. T. Hou, (2007); Effect of Machining Parameters on Surface Textures in EDM of Fe-Mn-Al Alloy, *Materials Science and Engineering*, **A 466**, 61-67.
- [2] H. Ramasawmy, and L. Blunt, (2003); Effect of EDM Process Parameters on 3D Surface Topography, *Journal of Materials Processing Technology*, **148**, 155-164.
- [3] S. F. Krar, A. R. Gill, and P. Smid, (2005); Technology of Machine Tools: Electrical Discharge Machining, 831-836.
- [4] D. Mickelson, (2004); Hard Milling & High Speed Machining: Tool of Change. Innovative Hard Machining of Forging Die Eliminates EDM, 158-162.
- [5] H. El-Hofy, (2005); Advance Machining Processes: Thermal Processes: Electro Discharge Machining, 115-140.
- [6] J. R. Linkbeck, M. W. Williams, and R. M. Wygant, (1990); Manufacturing Technology Special Machining Methods: Electrical Discharge Machining, 316-318.

- [7] R. G. Bruce, W. K. Dalton, J. E. Neely and R. R. Kibble, (2004); Modern Materials and Manufacturing Processes: Nontraditional Manufacturing Process Electro Discharge Machining, 291-293.
- [8] S. Kuriakose, and M. S. Shunmugam, (2004); Characteristics of Wire-electro Discharge Machined Ti6Al4V Surface, *Journal of Materials Science and Engineering*, **58**, 2231-2237.
- [9] S. Kapaljian, and S. R. Schmid, (2003); Manufacturing Process for Engineering Materials: Wire-EDM.
- [10] H. Ramasawmy, L. Blunt and K. P. Rajurkar, (2005); Precision Engineering, *Journal of Materials Science and Engineering*, **29**, 479-490.
- [11] Y. H. Guu, H. Hocheng, C. Y. Chou and C. S. Deng, (2003); Effect of Electrical Discharge Machining on Surface Characteristics and Machining Damage of AISI D2 Tool Steel, *Journal of Materials Science and Engineering*, **A358**, 37-43.
- [12] Y. Keskin, H. S. Halkaci, H.S and M. Kizil, (2006); *Int. Advance Manufacturing Technology*, **28**, 1118-1121.
- [13] G. Cheng, F. Han, and Z. Feng, (2007); Experimental Determination of Convective Heat Transfer Coefficient in WEDM.
- [14] S. Saha, M. Pachon and A. Ghoshal, (2005); Finite Element Modeling and Optimization to Prevent Breakage in Electro-Discharge Machining, 451-463.
- [15] W. F. Smith, (2004); Foundations of Materials Science and Engineering: Low Alloy Steels, 461-463.
- [16] V. F. C. Lins, M A. Freitas and E. M. P. Silva, (2005); *Application Surface Science*, **250**, 124-134.
- [17] H. H. Huang and T. H. Chuang, (2000); *Material Science Engineering*, **A292** (1), 90-95.
- [18] C. J. Wang, J W. Lee and T. H. Twu, (2003); Surface Coating Technology, **37**, 163-164.
- [19] K. H. Ho and S. T. Newman, (2003); *Journal of Machining Tools Manufacturing*, **43**, 1287-1300.
- [20] A. E. Ekmekci, Tekkaya, A. Erden, (2006); *Journal of Machining Tools Manufacturing*, **46**, 858-868.
- [21] M. S. Phadke, (1989); Quality Engineering Using Robust Design, Prentice Hall, Englewood Cliffs, New Jersey.
- [22] F. V. Dijck and R. Snoeys, Metal Removal and Surface Layer in Electro Discharge Machining, *Proceedings of the International Conference on Production Engineering*, Tokyo, Japan, 46-50.
- [23] K. J. Stout, P.J. Sullivan, W. P. Dong, E. Mainsah, N. Luo, T. Mathia and H. Zahouani, (1993); The Development of Methods for the Characterization for Roughness in Three Dimensions, EUR 15178 EN, 217-246.
- [24] I. N. Vuchkov and L. N. Boyadjieva, (2001); Quality Improvement with Design of Experiments: A Response Surface Approach, *Kluwer Academic Publishers. Dordrecht*, 740-741.