

NUMERICAL STUDY ON THE EFFECT OF GEOMETRICAL PARAMETERS ON THE PERFORMANCE OF VORTEX TUBE COOLING DEVICE USING SIMFLOW

**Mohd Hazwan bin Yusof*¹, Muhammad Fadhli bin Suhaimi¹, Mohd Hilmi bin Mohd Aris¹
and Syed Mohammad Akhtar¹**

¹ Faculty of Mechanical Engineering, Universiti Malaysia Pahang, 26600, Pekan, Pahang, Malaysia
(E-mail: mohdhazwan@ump.edu.my)

*corresponding author

ABSTRACT

Vortex tube is a simple device which can separate room temperature compressed gas into the cold and hot flow. The performance of vortex tube is mainly affected by its geometrical parameters. In this study, the parameters are focused on cold outlet diameter and hot tube length. The objective of this study is to investigate the effect the cold outlet diameter and hot tube length in the range of 4-5 mm and 175-194 mm, respectively, when the inner diameter of vortex tube is 10 mm. The numerical investigation was carried using SIMFLOW 2.1 to predict the performance of vortex tube. The results show that 4 mm cold outlet diameter and 175 mm hot tube length is the optimum parameter for 10 mm inner tube diameter of the vortex tube.

Keywords: Vortex tube, Cold exit diameter, Hot tube length, SIMFLOW

INTRODUCTION

The vortex tube is a simple cooling device which can separate a room temperature pressurized gas into two different temperature of flow, cold flow, and hot flow. It is small and has no moving part. Therefore, no maintenance is needed. Figure 1 shows a schematic drawing and flow pattern of a vortex tube. A vortex tube consists of one or more inlet nozzles, a cold exit, a hot exit, a vortex chamber, a control valve, and a hot tube. The working principles of the vortex tube are as follows. Pressured gas is tangentially injected into the vortex chamber through the inlet nozzles to create a strong swirl flow. Then, the strong swirl flow is expanded and cooled at the center of the vortex chamber, while a higher temperature of flow is created at the peripheral of the tube. This phenomenon is known as temperature separation phenomenon. Then, the flow moves towards the hot exit at the other end of the tube and the peripheral flow leaves the tube through the hot exit as hot flow. Flow at the center of the tube will counter-flow, and exit through the cold exit near the inlet nozzle as cold flow. The control valve at the hot exit is used to control the mass flow rate of hot flow by the gap created between the control valve and the inner side of the tube. This gap is controlled when the control valve is moved inwards or outwards the tube.

Vortex tube was created by Ranque in 1933 [1]. Then, he patented vortex tube in 1934 [2]. For more than 10 years, vortex tube was not gaining any attention until a German physicist, Hilsch studied the performance of this cooling device in 1947 [3]. Some of the investigations on the performance of vortex tubes are briefly mentioned below. Saidi et. al. [4] used a thermodynamics model for investigating vortex tube energy separation via exergy analysis, which is a new approach. Dutta et al. [5] used a three dimensional Computational Fluid Model (CFD) to investigate the energy and species separation phenomenon inside vortex tube. In their work, compressed air at a normal atmospheric temperature and the cryogenic temperature is used as the working fluid. They found that the energy and species separation is better at normal atmospheric temperature. Behera et al. [6]

conducted a numerical and experimental study to determine the optimum geometrical parameters for vortex tube. Later in 2008 [7], they developed a three dimensional numerical model to analyze the flow pattern and energy separation mechanism inside the tube. They reported that a free vortex region exists inside the tube. Secchiaroli et al. [8] conducted a numerical simulation of the internal flow vortex tube by both RANS (Reynolds-averaged Navier-Stokes equations) and LES (Large eddy simulation, mathematical modelling of turbulence) technique. They concluded that the numerical simulation is accurate to predict the cooling performance of vortex tube.

In this study, a numerical simulation using SIMFLOW ver. 2.2 is conducted to study the effects of tube length and cold outlet diameter to the performance of the vortex tube cooling device. The pressure and temperature distribution in the vortex chamber near inlet nozzle is also plotted to clarify the existence of temperature separation phenomenon inside vortex tube.

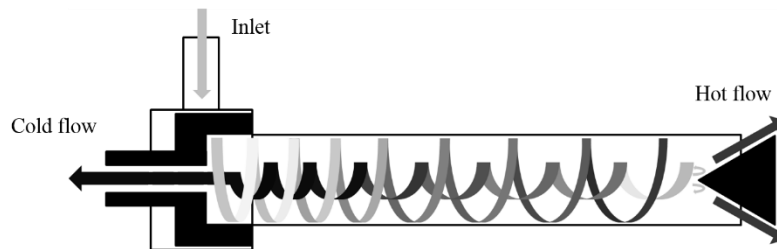

Figure 1. Flow pattern inside vortex tube.

MATHEMATICAL MODELS

Modelling

Open source CAD software, FreeCAD ver. 0.15 is used to create a model of vortex tube as shown in Figure 2. From the figure, vortex tube model is cut into blocks with 6 surfaces to perform hexahedral meshing. In this study, the effect of length and cold outlet diameter is to be determined. Therefore, three different length of the tube ($L=175, 186, \text{ and } 194 \text{ mm}$), and cold outlet diameter ($d=4, 4.6, \text{ and } 5 \text{ mm}$) is selected. Two nozzle number with an area of $2 \times 2 \text{ mm}$ is chosen throughout the simulation. The inner diameter, D for this model is 10 mm . Therefore, the length to inner diameter ratio (L/D) and cold outlet diameter to inner diameter ratio (d/D) is $L/D = 17.5, 18.6, 19.4$ and $d/D = 0.4, 0.46, 0.5$, respectively. In this study, 6 models are created.

Meshing

Hexahedral meshing for vortex tube model is performed by an open source meshing software, Salome 7.7.1 as shown in Figure 3. Before hexahedral mesh is chosen, vortex tube model is meshed with tetrahedron mesh. After some trials, tetrahedral mesh failed to perform the simulation. Therefore, the more stable hexahedral mesh is selected. To perform hexahedral meshing, the model is needed to be cut into blocks with 6 surfaces as mentioned in the previous section. The nodes for all 6 models is about 99,000 nodes.

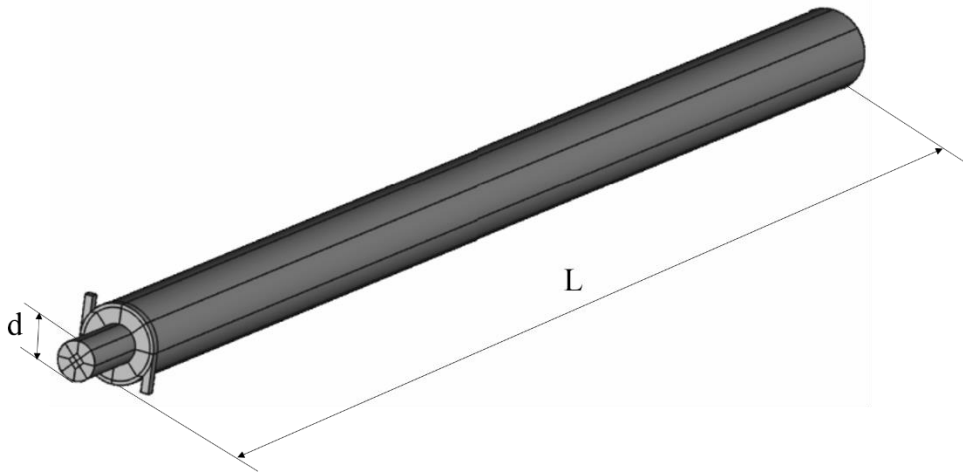

Figure 2. Vortex tube model created with FreeCAD ver. 0.15

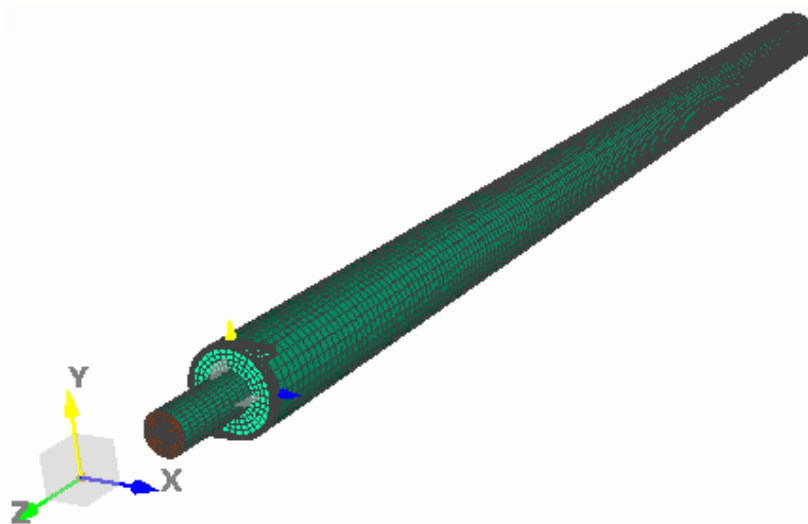

Figure 3. Computational mesh of vortex tube

Turbulence Modelling

Vortex tube uses compressed gas. Therefore, a relatively high Reynolds Number region, turbulent flow is expected. SimFlow ver 2.2 is used to perform the numerical simulation. This simulation software is based on open source OpenFOAM software (Linux platform), and works on Windows platform. It also comes with a user friendly interface, where users need no longer to type in the codes, but can select it from the menu. It's free licensed can be used for mesh with less than 100,000 nodes. In this study, mesh with approximately 99,000 nodes is used.

Rans k- ϵ model is selected as the turbulence model. The solver used for this simulation is steady-state rhoSimplecFoam.

Boundary Conditions

The pressure, temperature and turbulence intensity for inlet is modelled as fixed value of 0.4 MPa, 300 K, and 5%, respectively. The walls of the system is a non-slip boundary condition. The cold and hot outlets are modelled as Inlet-Outlet with a temperature of 300 K. The pressure at the cold outlet is set at atmospheric pressure (0.1 MPa). The pressure at the hot outlet is varied to control the mass flow rate at the cold and hot outlet.

MAIN RESULTS

Temperature separation inside vortex tube is mainly happened in vortex chamber near the inlet nozzle. Therefore, in this research, the pressure and temperature at a cross sectional area near the inlet nozzle is plotted from the simulation results.

The performance of vortex tube is mainly based on the cold outlet temperature. To study the effects of length and cold outlet diameter, the pressure and temperature at a cross sectional area of the cold exit is derived from the simulation results.

Effects of Length of Tube

Figure 4 (a) and (b) show the pressure and temperature at a cross sectional area of tube near the inlet nozzle, respectively. For Figure 4 (a), the horizontal axis is pressure, P in Pascal and the vertical axis is the distance from the center of the tube to the tube's wall. For Figure 4 (b), the horizontal axis is temperature, T in Kelvin, and the vertical axis is same as Figure 4 (a). L175, L186, and L194 in Figure 4 represents the length of the tube, which is $L=175$, 186, and 194 mm, respectively.

From Figure 4 (a), it can be understood that the pressure gradient for all length is identical. The lowest pressure is at the center of the tube. This is due to the vortex flow near the inlet is a force vortex. Therefore, the radial velocity at the center of the vortex is 0, which results the lowest pressure. The highest pressure is as expected to be near the wall. L186 and L194 show almost similar results, and L175 have the highest pressure distribution.

From Figure 4 (b), the lowest temperature is at the center of the tube (292 K). This is due to sudden expansion of compressed gas. It should be noted that inlet temperature is 300 K, and the temperature of the flow near the wall is almost 40 K greater than the inlet. Therefore, the temperature separation of vortex tube is observed from this simulation. The temperature distribution for L175, L184, and L196 is almost similar to each other. Form the pressure distribution at Figure 4 (a), L175 is expected to have a higher temperature distribution. The other factors may affect the results, and further investigation is needed.

Figure 5 (a) and (b) show the pressure and temperature at a cross sectional area of tube near the inlet nozzle, respectively. The horizontal and vertical axis is same as Figure 4. From Figure 5 (a), the pressure gradient for all length is similar. From the pressure distribution, it is clear that the flow was changed to laminar flow at the cold exit. The pressure distribution of L175 is the lowest and L194 is the highest. From Figure 5 (b), the lowest temperature distribution is L175. This is due to the pressure at L174 is the lowest among other lengths. Therefore, we can conclude that the length of $L=175$ mm is the optimum length for vortex tube.

Effects of Cold Outlet Diameter

Figure 6 (a) and (b) show the pressure and temperature at a cross sectional area of the tube near the cold outlet, respectively. The label d_4 , $d_{4.6}$ and d_5 represents the cold outlet diameter,

$d=4, 4.6, \text{ and } 5 \text{ mm}$, respectively. From Figure 6, d_4 has the smallest distance from the center, and d_5 has the longest distance from the center. From Figure 6 (a), the pressure distribution increases when the diameter decrease. It can be seen from Figure 6 (b) that the lowest temperature at the center of the tube is obtained when the diameter is 4 mm. Therefore, it can be concluded that optimum diameter for cold outlet diameter is 4 mm. Also, a further study on smaller diameter of the cold outlet is suggested.

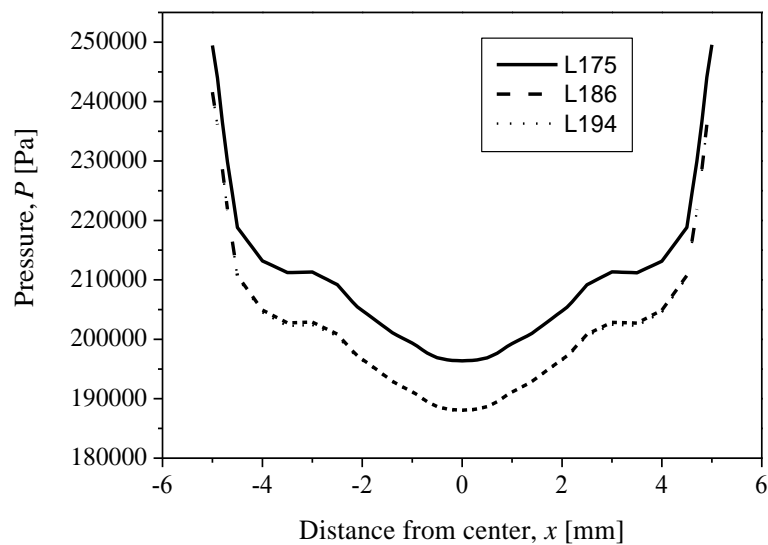

(a)

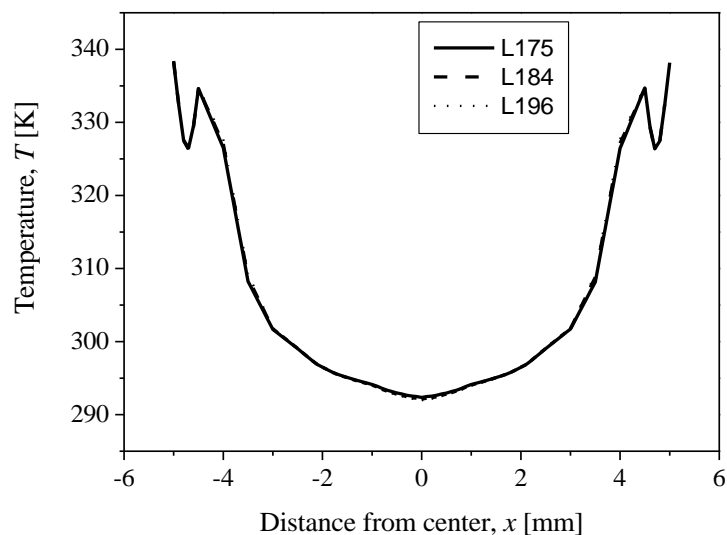

(b)

Figure 4. (a) Pressure distribution near inlet at $L=175, 184, \text{ and } 196 \text{ mm}$, (b) Temperature distribution near inlet at $L=175, 184, \text{ and } 196 \text{ mm}$.

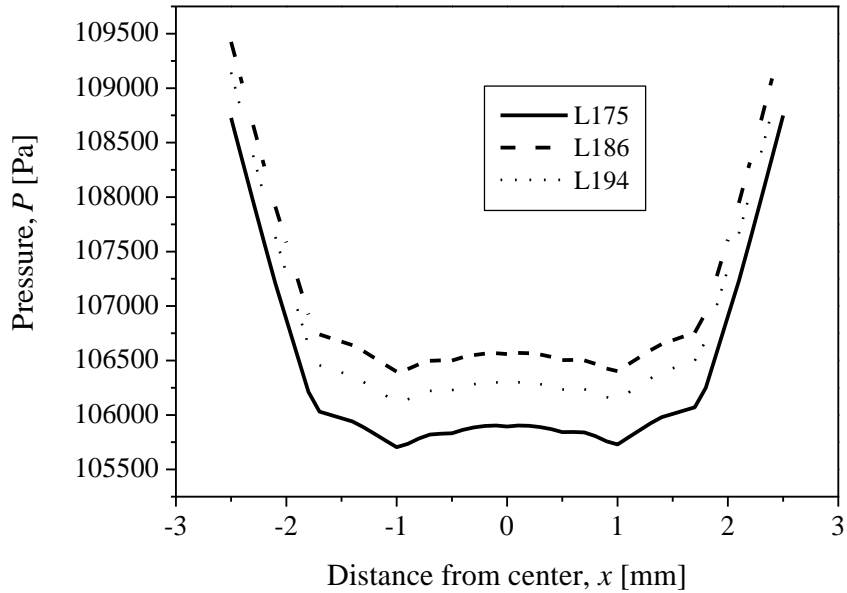

(a)

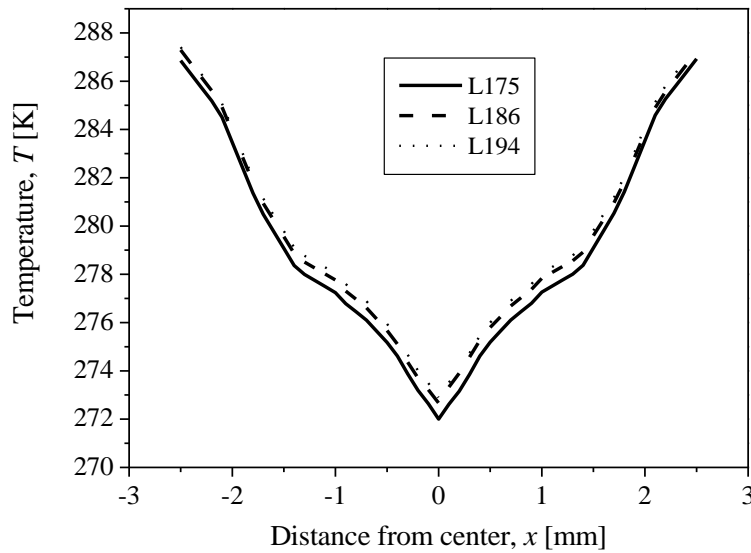

(b)

Figure 5. (a) Pressure distribution near cold outlet at $L=175, 184,$ and 196 mm,
 (b) Temperature distribution near cold outlet at $L=175, 184,$ and 196 mm.

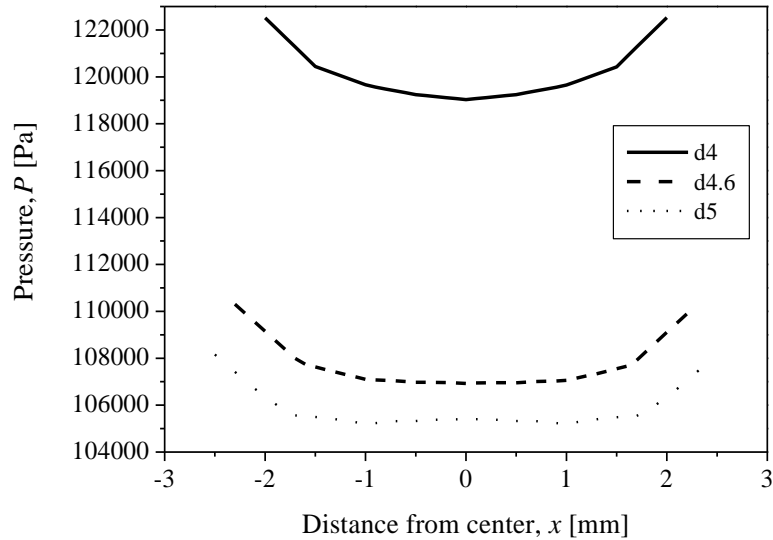

(a)

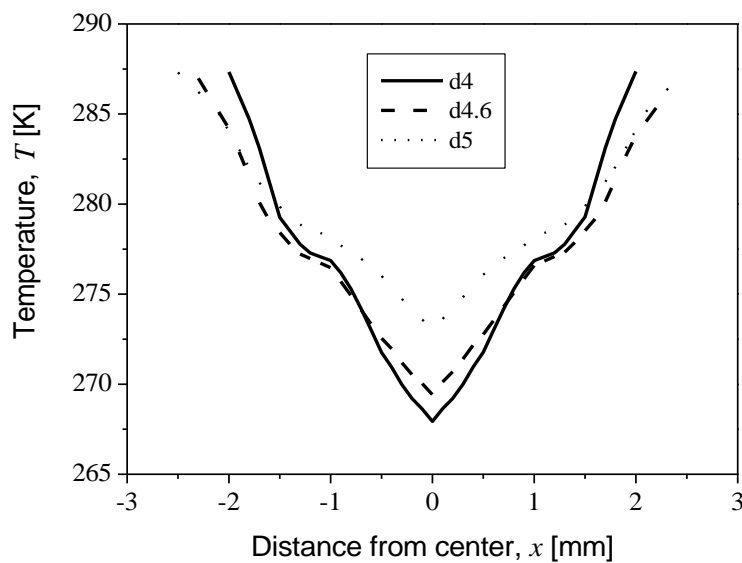

(b)

Figure 6. (a) Pressure distribution near cold outlet at $d=4, 4.6,$ and 5 mm,
 (b) Temperature distribution near cold outlet at $d=4, 4.6,$ and 5 mm.

CONCLUSION

A numerical simulation is conducted to clarify the effects of tube length and cold outlet diameter to the performance of the vortex tube cooling device using SIMFLOW ver. 2.2. The temperature separation phenomenon is verified from the pressure and temperature distribution

near the inlet nozzle where the phenomenon is occurred. From the pressure and temperature distribution at the cold exit, it is clarified that the optimum length and cold outlet diameter for 10 mm inner tube of vortex tube is 175 mm and 4 mm, respectively. Further investigation is suggested due to the possibility of lower value as the optimum value.

REFERENCES

- [1] G. Ranque, "Experiences sur la détente giratoire avec production simultanées d'un échappement d'air chaud et d'air froid (in French)," *J. Phys. le Radium*, vol. 7, no. 4, pp. 112–114, 1933.
- [2] G. Ranque, "Method and Apparatus for Obtaining from a Fluid under Pressure Two Outputs of Fluid at Different Temperatures," US Patent, 1,952,281, 1934.
- [3] R. Hilsch, "The Use of the Expansion of Gases in a Centrifugal Field as Cooling Process," *Rev. Sci. Instrum.*, vol. 18, no. 2, pp. 108–113, 1947.
- [4] M. H. Saidi and M. R. A. Yazdi, "Exergy model of a vortex tube system with experimental results," *Energy*, vol. 24, pp. 625–632, 1999.
- [5] T. Dutta, K. P. Sinhamahapatra, and S. S. Bandyopadhyay, "Numerical investigation of gas species and energy separation in the Ranque-Hilsch vortex tube using real gas model," *Int. J. Refrig.*, vol. 34, no. 8, pp. 2118–2128, 2011.
- [6] U. Behera, P. J. Paul, S. Kasthuriengan, R. Karunanithi, S. N. Ram, K. Dinesh, and S. Jacob, *CFD analysis and experimental investigations towards optimizing the parameters of Ranque-Hilsch vortex tube*, vol. 48, no. 10. 2005, pp. 1961–1973.
- [7] U. Behera, P. J. Paul, K. Dinesh, and S. Jacob, "Numerical investigations on flow behaviour and energy separation in Ranque-Hilsch vortex tube," *Int. J. Heat Mass Transf.*, vol. 51, no. 25–26, pp. 6077–6089, 2008.
- [8] A. Secchiaroli, R. Ricci, S. Montelpare, and V. D'Alessandro, "Numerical simulation of turbulent flow in a Ranque-Hilsch vortex tube," *Int. J. Heat Mass Transf.*, vol. 52, no. 23, pp. 5496–5511, 2009.