



MODELING OF TEMPERATURE AND AIRFLOW PATTERN IN A REFRIGERATOR

Muhammad E. Haque¹, Rosli Abu Bakar², Gan Leong Ming² and M Shakaib²

¹NED University of Engineering and Technology, Karachi, Pakistan

²Department of Mechanical Engineering, Universiti Malaysia Pahang, Malaysia

E-Mail: mehaque101@yahoo.com

ABSTRACT

Several researchers have shown that Computerized Fluid Dynamics (CFD) can be successfully used for mathematical modeling of refrigeration systems. In this paper authors developed a CFD model for a domestic no-frost refrigerator. The conservation equations of energy mass and momentum are solved by using Finite Volume Method in an environment of three dimensional unstructured mesh. Experiments were conducted on a no-frost domestic refrigerator to compare and validate the results of the CFD model. Both the results from the CFD model and experiment are qualitatively similar even though there are certain discrepancies due to some insufficient information available for the numerical model.

Keywords: CFD, numerical simulation, mathematical modeling, domestic, no-frost refrigerator, finite volume method.

INTRODUCTION

Unlike air conditioner, washing machine and some other home appliances a refrigerator is using power continuously, twenty four hours a day and seven days a week. The general consumer is concerned with both the performance and efficiency of it. In this world of seven billion people there are estimated one billion refrigerators worldwide. Production in developing countries is rising rapidly. In the countries included in Asia Pacific Economic Cooperation, the production of household refrigerator is about 60 million out of worldwide production of a 100 million [1]. In Malaysia 76% household are equipped with refrigerator and about 20% of power produced in the country is consumed by these appliances [1]. Even though the average compressor in a domestic refrigerator is about 100 W but due to their large numbers and continuous operation they consume a large amount of energy. On the one hand consumers are demanding better and better performance and on the other hand government's environmental regulations are compelling the industry to improve the basic design structure of the refrigerator and look for alternative working substances which are friendlier to environment. The main environmental concern is the global warming and Ozone Depletion in the stratosphere. In many of the research papers, several options have been discussed for the improvement of refrigerator. Understanding and improving the air flow pattern and temperature profiles inside a refrigerating compartment can help in one side for better usage of refrigerated space for keeping the food fresh and on the other side it can help to improve the performance and energy efficiency of the refrigerator. This paper focuses on this aspect of the domestic refrigerator.

Many of the scholars have used CFD to predict the air flow and temperature profile inside the refrigerated compartment such as [2], [3], [4], their work indicates that there is a temperature stratification inside the refrigerator in vertical direction. There is a high temperature region at the top and a low temperature region in the bottom. The temperature becomes more uniform if the refrigerator is loaded. In another work [5], investigated evaporation and

condensation inside the refrigerator. They found out that evaporation or dehydration is occurring close to the door of the refrigerator and condensation is generally occurring close to the evaporator surface.

Measuring velocity of the air flow inside a refrigerator is a difficult task due to the compact design of the refrigerator. [6] used PIV technique to measure air velocity inside a modeled static refrigerator. Their finding is that the air moves in a circle inside the refrigerated compartment with a high velocity closed to the cold wall and lower velocity at the other end. In an empty refrigerator air at the center of the cabinet is almost stagnant. In another work [7] measured air flow velocity inside a freezer compartment of a no-frost refrigerator. Their conclusion was that the performance of a refrigerator can be improved by understanding the air flow pattern, velocity of the air and temperature profile of the air.

Several author suggested modifications both inside and outside of the refrigerator [3, 8-10] and compared their air flow velocity, temperature profile and energy consumption before and after the modifications. Some of the modifications are simple and easy to implement but others are cost prohibitive. On the other hand [11] worked on the space surrounding the refrigerator. According to the researcher a minimum of 200 mm space between the condenser coil and the wall can significantly increase the heat rejected to the ambient air.

In this paper a commercial CFD software is used to investigate airflow and temperature profile of a domestic frost-free refrigerator. A comparison of the CFD model is then carried out with the data collected from experiments.

NUMERICAL SIMULATION PROCEDURES

Mathematical modeling

Main assumptions, governing equations and boundary conditions. For the mathematical model following simplified assumptions are made, [12]



- The default fluid inside the refrigerator is considered to be incompressible. This assumption is justified because Mach number ($Ma \approx 10^{-3}$), as it is typical to the present system.
- In the energy equation, the viscous dissipation terms are neglected as the values of the product Eckert number and Prandtl number is low (i.e. $Ec \times Pr \approx 10^{-4}$ or less)
- A steady state case is being analyzed. In real situation the continuous on and off cycling of the compressor makes the problem transient in nature. A steady state or a lowest temperature state can be achieved by removing the thermostat and letting the compressor work continuously.
- As a simplifying assumption the refrigerator is considered empty and effect of air leakage or frosting and mass transfer mechanisms are not considered.
- For flow modeling inside the refrigerating compartment and the freezer compartment buoyancy effects are neglected because of strong inertial effects ($Ri \approx 0.05$). Variations in thermo-physical properties are assumed to be small over the range of operating temperature.
- In the refrigerator compartment walls are not in direct contact with the evaporator and the temperature difference between the side walls and shelves are very small, in the range of 2 to 4 °C, therefore, the heat transfer due to radiation can be neglected but it is not neglected.
- Laminar flow is assumed in both compartments. This is justified in the refrigerating compartment as the Rayleigh number $Ra \approx 10^8$ or less.
- The condenser and evaporator are considered to be isothermal walls. These are incorporated in the domain with finite conductive resistances.
- Heat transfer between freezer and refrigerator compartments are assumed zero.
- At the inlet ports uniform velocity and temperature profiles are assumed.

The above assumptions results into the following mass momentum and energy equations:

$$\text{Continuity} \\ \frac{\partial u}{\partial x} + \frac{\partial v}{\partial y} + \frac{\partial w}{\partial z} = 0 \quad (1)$$

$$\text{X-momentum} \\ u \frac{\partial u}{\partial x} + v \frac{\partial u}{\partial y} + w \frac{\partial u}{\partial z} = -\frac{1}{\rho_o} \frac{\partial p}{\partial x} + \nu \nabla^2 u \quad (2)$$

$$\text{Y-momentum} \\ u \frac{\partial v}{\partial x} + v \frac{\partial v}{\partial y} + w \frac{\partial v}{\partial z} = -\frac{1}{\rho_o} \frac{\partial p}{\partial y} + \nu \nabla^2 v + g\beta(T - T_o) \quad (3)$$

$$\text{Z-momentum} \\ u \frac{\partial w}{\partial x} + v \frac{\partial w}{\partial y} + w \frac{\partial w}{\partial z} = -\frac{1}{\rho_o} \frac{\partial p}{\partial z} + \nu \nabla^2 w \quad (4)$$

$$\text{Energy equation} \\ u \frac{\partial T}{\partial x} + v \frac{\partial T}{\partial y} + w \frac{\partial T}{\partial z} = \alpha \nabla^2 T \quad (5)$$

Boundary conditions for the freezer and refrigerating compartment are listed in Table-1.

Table-1. Boundary condition for freezer and refrigerating compartments.

Boundary	Temperature	Velocity
Velocity inlet freezer	251	0.5 m/s, normal to boundary
Velocity inlet refrigerator	255	0.5 m/s, normal to boundary
Pressure outlet freezer	251	Zero normal gradient
Pressure outlet refrigerator	300	Zero normal gradient
Freezer left wall	300 K, Convective $h_o = 0.37 \text{ W m}^{-2} \text{ K}^{-1}$	No slip
Freezer bottom wall	Adiabatic	No slip
Freezer top wall	300 K, Convective $h_o = 0.37 \text{ W m}^{-2} \text{ K}^{-1}$	No slip
Freezer back wall	251 K, Convective $h_o = 11.11 \text{ W m}^{-2} \text{ K}^{-1}$	No slip
Front wall	300 K, Convective $h_o = 0.59 \text{ W m}^{-2} \text{ K}^{-1}$	No slip
Refrigerator left wall	330 K, Convective $h_o = 0.44 \text{ W m}^{-2} \text{ K}^{-1}$	No slip
Refrigerator bottom wall	327 K, Convective $h_o = 0.37 \text{ W m}^{-2} \text{ K}^{-1}$	No slip
Refrigerator top wall	Adiabatic	No slip
Refrigerator back wall	300 K, Convective $h_o = 0.37 \text{ W m}^{-2} \text{ K}^{-1}$	No slip



The values of the overall heat transfer coefficients were measured by the method of [13] and are verified by the equation given by [12] for thermal resistances offered by various heat transfer path as follows:

$$\frac{1}{h_o} = \frac{1}{h_a + h_r} + \frac{t_w}{k_w} \quad (6)$$

Where h_a is the ambient heat transfer coefficient, h_r is an equivalent heat transfer coefficient to account for the radiation effects, t_w is the wall insulation thickness and k_w is the thermal conductivity of the wall.

Numerical simulation

Simulation of the fluid domain as shown in Figure-1 was carried out in a CFD software. The Finite Volume discretization technique was used solve the conservation equations of mass, momentum and energy. The solution of the governing equations thus solved represent air flow velocity and air temperatures inside the refrigerator. A grid sensitivity study indicated that further refinement in the grid resolution will not change the numerical solutions noticeably.

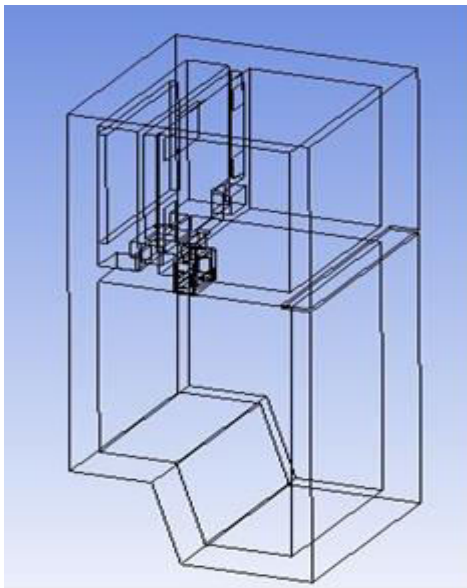

Figure-1. No-frost refrigerator.

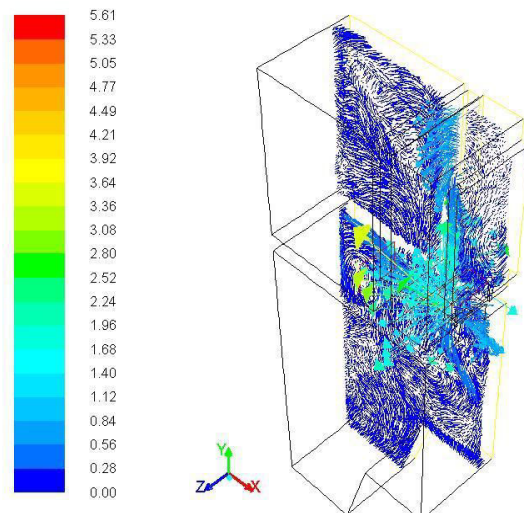

Figure-2. Velocity vectors at side panel $z=0.35\text{m}$.

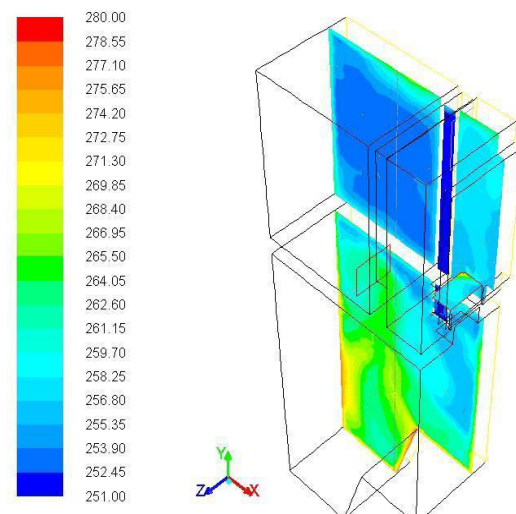

Figure-3. Temperature profile at $z=0.35\text{m}$.

RESULTS AND DISCUSSIONS

Air flow in the fridge

Figure-2 is showing a velocity profile of the air. In the freezer section it is coming out from the front inlet ports at a velocity of approximately 0.5 m/s. In the empty freezer without any shelves and trays, it travels to the front door and the circles around and finally leaves from the outlet ports. Similarly air enters the refrigerator portion from the duct between the evaporator compartment and the refrigerator at an inlet velocity of 0.5 m/s. It is circulating close to the walls as it travels down to the bottom of the refrigerator and finally circulating back to the outlet port into the evaporator chamber. This air which is moist and relatively hot when comes in contact with the evaporator coils become dry and cold and ready to be circulated again inside the refrigerator.



Temperature patterns in the fridge

Figure-3 shows the temperature profile on a side plane at $z=0.35\text{m}$. In the freezer compartment it is negative and varying between negative 22 to negative 12 degree Celsius. In the refrigerator section as the air travels down it becomes hotter, having the highest temperature at the bottom of the section. As this is an empty refrigerator without the shelves or racks, temperature is colder at the top and warmer at the bottom. The air is gaining heat from the surroundings. Due to the presence of the condenser in the left wall, the temperature close to this wall is higher. Similarly, there is high rate of heat transfer from the high temperature compressor compartment into the refrigerator at the bottom.

Figure-4 shows the velocity variation inside the freezing compartment on a line. It goes from 0 to 0.19 m/s without following any particular pattern due to forced flow. It is higher at both ends and lower at the middle. This is due to the location of the inlet vent of cold air into the freezer compartment. Figure-5 shows the temperature variation in the same section. It is fluctuating from 253 to 266 K. Cold air after circulating inside the freezer compartment settles down in the bottom before getting out through the outlet vent which are located close to the bottom of the freezer compartment. Therefore, the temperature is low at the bottom as compared to the top of the freezer.

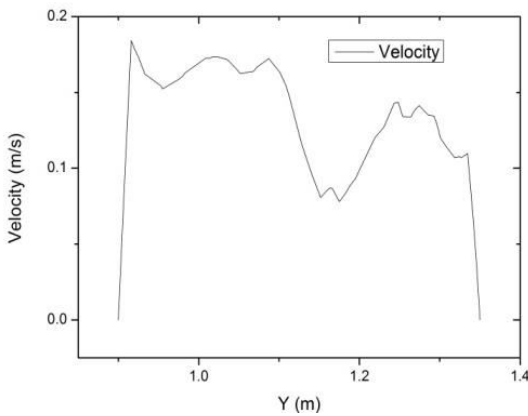

Figure-4. Velocity at line $x=0.2\text{ m}$, $z=0.35$.

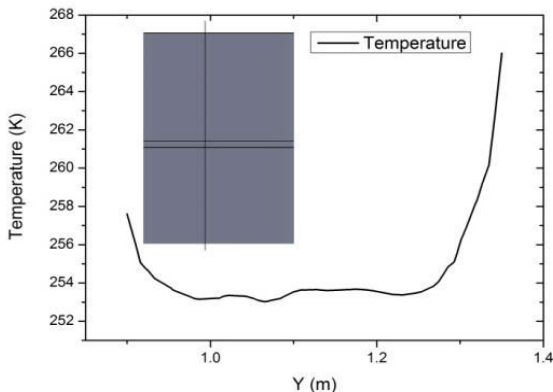

Figure-5. Temperature at $x=0.2$ and $z=0.35$.

Figure-6 shows the velocity variation inside the refrigerator section. It varies from 0 to a maximum of 0.4 m/s at the upper side of the refrigerator where the inlet port is. Air enters the refrigerator compartment at a relatively high velocity of 0.4 m/s from a location at the top of the refrigerator compartment. As it travel down its velocity becomes lower and lower. Figure-7 shows temperature variation inside the refrigerator. It is varying between a maximum of 275K to a minimum of 257K. The lower temperature is at the top where the cold air is entering from the evaporator chamber and the high temperature is at the bottom due to the heat gain from the surrounding and from the compressor compartment.

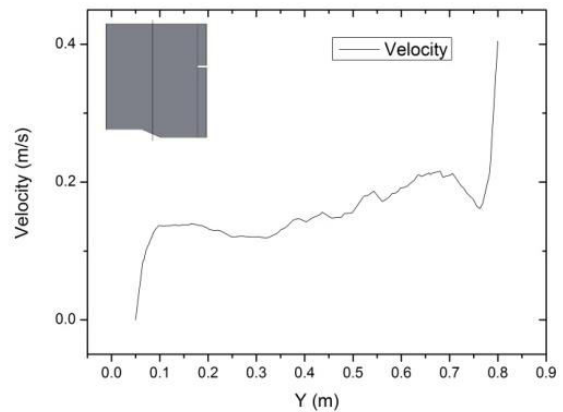

Figure-6. Velocity at line $x=0.2\text{ m}$, $z=0.35\text{m}$.

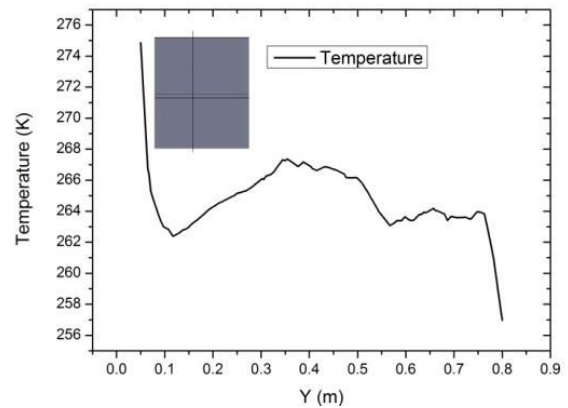

Figure-7. Temperature at line $x=0.2$ and $z=0.35$.

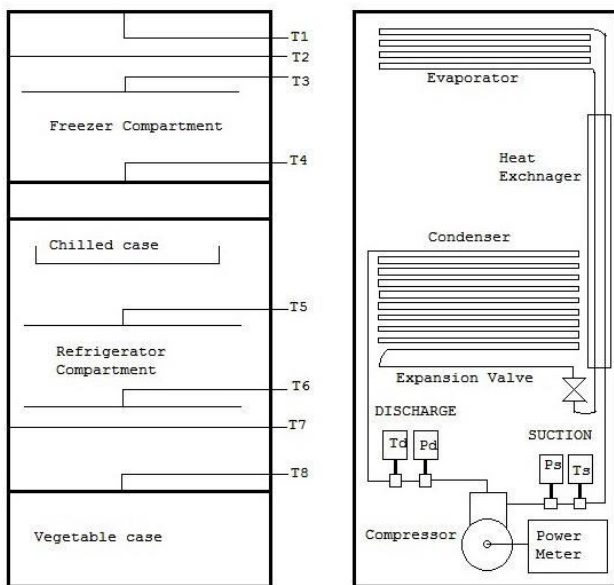

Figure-8. Schematic diagram of experimental apparatus.

Experiment for validation and comparison of numerical model

All the experiments were carried out in a room where the room temperature was 28 °C and humidity level was above 70%. A domestic 234 liter capacity, double door, no-frost refrigerator was used. The refrigerator specifications are listed in Table-2. Figure-8 shows the locations of the instrumentations and the surfaces at which thermocouples were placed. Twenty eight calibrated k type thermocouples were used to measure the temperature of the air inside the refrigerator. Temperatures were measured on all the four walls, including doors, of both freezer and refrigerator compartments and on all the shelves. The thermocouples reading were recorded every ten seconds by data loggers. The thermostat of the refrigerator was shorted in order to attain a steady state condition. As shown in Figure-9 when the power is turned on, fan draws the air on the evaporator coils and the air becomes cold. Cold air first enters into a box which separates the evaporator chamber from the freezer compartment. It then enters into the freezer compartment through the four vents and a small duct at the bottom of box leads cold air into the refrigerator compartment. After circulating in the freezer compartment, relatively hot air enters directly into the evaporator chamber through two vents at the bottom without entering into the cold air box. Similarly cold air after circulating into the refrigerator compartment enters into the evaporator chamber from two smaller ducts at the back of the refrigerator compartment. The air then continues to cycle through. As the thermostat is shorted the compressor keeps on working and in principle, a lowest temperature state is achieved when the heat gain from the surroundings becomes equal to the evaporator cooling capacity. This state is the steady state which is attained corresponding to a lowest possible temperatures prevailing inside the compartments. Since the numerical model computes for the steady state, the

computational results are validated against the lowest attainable temperature mentioned above.

Table-2. Specification of the refrigerator.

Description	Specifications
Gross Capacity	234L
Freezer compartment	75L
Fresh food compartment	159L
Outside dimensions (mm)	600X614X1449
Refrigerant type	HFC-134a
Charged mass	120 g
Compressor type	Recip. hermetically sealed
Compressor oil charge	195 ml
Power source	AC 240/50Hz
Weight	43kg

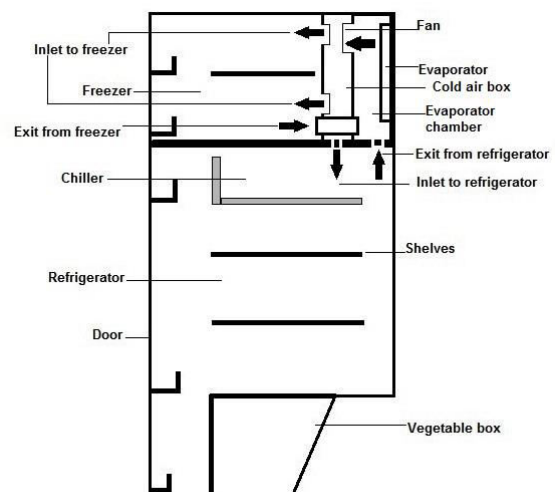

Figure-9. Air flow and heat transfer in refrigerator.

Figure-10 is showing the temperature variation on a vertical line at the center of the freezer compartment. Six thermocouples were placed along this line. It can be seen from the numerical results that the temperature first drops and then becomes constant and finally rises up slowly. This pattern of temperature change is due to cold air entering from the upper vents and slowly moves down and settle down at the bottom of the freezer compartment and as it gains some heat it rises up. The trend shown by the experimental data is similar, that is the temperature at the floor of the freezer compartment is lowest and stays constant. The numerically predicted temperatures and experimental temperatures are compared, at selected points along the vertical central line in freezer compartment, in Table-3. The difference between the numerical and experimental temperatures could be due to the error in measurement and lack of information about the actual airflow rate occurring.

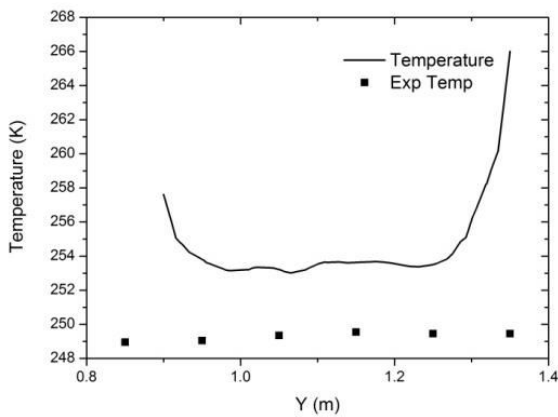

Figure-10. Comparison of numerical and experimental results at symmetry plane of freezer ($x=0.2$ and $z=0.35$).

Table-3. Comparison of numerical and experimental temperatures at selected points on a vertical line in freezer.

Point	Temperature (K)	
	Numerical	Experimental
1	253.9	249.1
2	253.2	249.4
3	253.6	249.6
4	253.5	249.5

Figure-11 shows the variations in numerically predicted temperatures and experimental temperatures along a central vertical line in the refrigerator compartment. The trend of the two temperature profiles are similar that is cold air is entering at the top of the refrigerator compartment and as it moves down it gains temperature from the surrounding walls. The numerically predicted temperature is always lower than the actual experimental temperature. This could be due to the air leakage from the gasket of the door which is not considered in the numerical model. Further more, the temperature of the back wall of the refrigerator is assumed to be constant and equal to the condenser temperature in the numerical model. This assumption could be an underestimate because of the presence of the hot air coming from compressor and de-superheating condenser coils. Table-4 shows a comparison of numerically predicted and experimentally recorded temperatures on selected points along a vertical central line in the refrigerator compartment. The difference between the two temperatures is due to insufficient information available of actual airflow rate but both of them are showing that the temperature of air increases as it moves down.

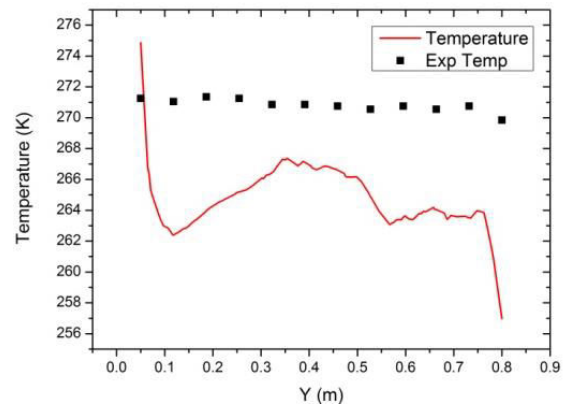

Figure-11. Comparison of numerical and experimental results at symmetry plane of refrigerator ($x=0.2$ and $z=0.35$).

Table-4. Comparison of numerical and experimental temperatures at selected points on a vertical line in refrigerator.

Point	Temperature (K)	
	Numerical	Experimental
1	270.6	264.8
2	270.8	266.7
3	270.9	267.2
4	270.9	266.4
5	271.3	265.0

CONCLUSIONS

The numerical model of no-frost refrigerator was developed and simulated using a finite volume method with an unstructured mesh. An experiment was conducted and temperatures were noted in order to validate the numerical model. The trend of temperature variations is similar in both of the numerical model and experimental results. In freezer compartment the predicted temperatures are higher than the experimental results. This could be due to insufficient information on airflow rate. In refrigerator compartment computational temperatures are marginally lower than the experimentally observed temperatures. This difference in temperature could be due to the heat leakage from the door gasket which is not considered in the numerical model. Another reason could be the uniform temperature assumption at the back wall of the refrigerator which in actuality varies due to hot air from compressor and de-superheating to sub-cooling temperatures of the refrigerant. This model is capable of predicting temperature and velocity profile inside the refrigerator. This model will be further refined to enhance its prediction in future publications.

REFERENCES

[1] Saidur R., Masjuki H. H., and Choudhury I. A. 2002. Role of ambient temperature, door opening,



- thermostat setting position and their combined effect on refrigerator-freezer energy consumption. *Energy Conversion and Management*. 43(6): 845-854.
- [2] Laguerre O., Amara S. B., and Flick D. 2005. Experimental study of heat transfer by natural convection in a closed cavity: application in a domestic refrigerator. *Journal of Food Engineering*. 70(4): 523-537.
- [3] Afonso C. and Matos J. 2006. The effect of radiation shields around the air condenser and compressor of a refrigerator on the temperature distribution inside it. *International Journal of Refrigeration*. 29(7): 1144-1151.
- [4] Laguerre O., Amara S. B., Charrier-Mojtabi M. C., Lartigue B., and Flick D. 2008. Experimental study of air flow by natural convection in a closed cavity: Application in a domestic refrigerator. *Journal of Food Engineering*; 85(4): 547-560.
- [5] Farid M. M. (Ed.). 2010. *Mathematical modeling of food processing*. CRC Press.
- [6] Amara S. B., Laguerre O., Charrier-Mojtabi M. C., Lartigue B., and Flick D. 2008. PIV measurement of the flow field in a domestic refrigerator model: Comparison with 3D simulations. *International Journal of Refrigeration*. 31(8): 1328-1340.
- [7] Lacerda V. T., Melo C., Barbosa J. R., and Duarte P. O. O. 2005. Measurements of the air flow field in the freezer compartment of a top-mount no-frost refrigerator: the effect of temperature. *International Journal of Refrigeration*. 28(5): 774-783.
- [8] Fukuyo K., Tanaami T., and Ashida H. 2003. Thermal uniformity and rapid cooling inside refrigerators. *International Journal of Refrigeration*. 26(2): 249-255.
- [9] Ding G. L., Qiao H. T., and Lu Z. L. 2004. Ways to improve thermal uniformity inside a refrigerator. *Applied Thermal Engineering*. 24(13): 1827-1840.
- [10] Afonso C. F. 2013. Household refrigerators: Forced air ventilation in the compressor and its positive environmental impact. *International Journal of Refrigeration*. 36(3): 904-912.
- [11] Bassiouny R. 2009. Evaluating the effect of the space surrounding the condenser of a household refrigerator. *International Journal of Refrigeration*. 32(7): 1645-1656.
- [12] Gupta J. K., Gopal M. R., and Chakraborty S. 2007. Modeling of a domestic frost-free refrigerator. *International Journal of Refrigeration*. 30(2): 311-322.
- [13] Laguerre O., Amara S. B., Moureh J., and Flick D. 2007. Numerical simulation of air flow and heat transfer in domestic refrigerators. *Journal of Food Engineering*. 81(1): 144-156.