

PAPER • OPEN ACCESS

Simulation of leaching process of gold by cyanidation

To cite this article: F N Yahya *et al* 2020 *IOP Conf. Ser.: Mater. Sci. Eng.* **736** 022111

View the [article online](#) for updates and enhancements.

Simulation of leaching process of gold by cyanidation

F N Yahya, W H W Ibrahim*, B A Aziz, L N M Suli

Faculty of Chemical and Process Engineering Technology, College of Engineering Technology, University Malaysia Pahang, Gambang 26300, Pahang, Malaysia

*anisah@ump.edu.my

Abstract. Sodium Cyanide (NaCN) has been used to recover gold from gold bearing ores. This work aims to develop a simulation model of leaching process by using cyanide solvent for the dissolution of gold by using HSC simulator. The results from this simulation were compared with other researcher which employed Aspen Plus and it shows very good agreement with very small error (<1.5%). The cases study was carried out using the developed process model where hydrochloric acid (HCl) was used as solvent, the effect of different concentration of Au in ores and the effect of different concentration of solvent as a leaching reagent. The results show that the chlorination process gives higher amount of gold (Au) dissolved in the solvent compared to cyanidation process. The develop process model provide an effective means for studying the solid liquid leaching process in the future.

1. Introduction

Gold were first discovered as soft metallic element and the oldest pieces of gold jewellery in the tombs of Queen Zer of Egyptian and Queen PU-abi of Urin Sumeria. Gold became a part of every human culture because gold is dispersed widely throughout the geologic world. World's largest gold producing countries are China, Australia, Russia and United States. In periodic table, gold or Aurium (Au) is located in transition metal with 79 atomic number and electron configuration is [Xe] 4f14 5d10 6s1.

Gold is one of the mineral resources which can be separate from gold bearing ores by separation process. Separation process is the transfer of any mass that converts the substance mixture into distinctive product mixtures. Types of separation process that is appropriate for gold processing is leaching process. Leaching is a process of extracting a soluble constituent from a solid by means of solvent [1]. Leaching processes also are used extensively in the metals processing industries and is a main stage of reactant in gold production [2].

Typically, gold is leached from its ore using an aqueous sodium cyanide solution. Cyanide has featured prominently as a leach reagent at gold mines because of its high efficiency, robustness and relatively low cost. But, cyanide gave the environmental damages resulting from its mismanagement, thus, have initiated widespread research aimed at identifying and developing less toxic leaching agent [3]. A teaspoon of a 2%



cyanide solution can kill a person [4]. These can be exposed to cyanides by breathing air and drinking water, touching soil or water containing cyanide, or eating foods that contain cyanide [5].

Based on the title of this research, simulators are used to simulate the liquid-solid leaching process by using cyanide as a solvent for the dissolution of gold. HSC Chemistry is one of simulators that will be used. HSC Chemistry is a versatile tool for thermodynamically and process calculation. The program calculates the steady state of the process. Its many automated functions speed up process calculation [6].

2. Literature review

2.1. Process of gold

Figure 1 shows the general block flow diagram for fundamental unit process for production gold plant which consists of crushing and grinding, leaching, filtering, carbon adsorption and elution, refining and waste treatment. It's starting from all particles of solids (ores) are sent to the crushing and grinding section for size reduction.

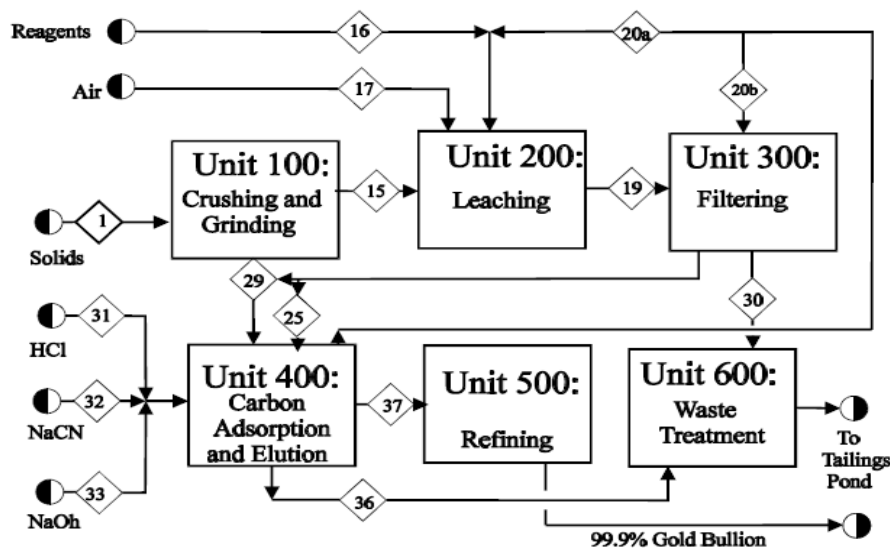

Figure 1. Block flow diagram of gold production process.

The chemistry and phenomena in gold cyanidation is highlighted as it is an important factor in the production of gold. From previous study, the leaching or dissolution of the gold occurs in the following steps: (1) Diffusion of reactant in solution through a liquid film to the unreacted gold surface; (2) Chemical reaction of the reactants in solution with the metallic gold; (3) Diffusion of products through a film boundary layer away from the surface [7].

The dissolution gold can be more explains by the shrinking core model and diffusion mechanisms [8]. The shrinking core model are the model developed to describe heterogeneous non-catalytic reaction kinetic. In heterogeneous liquid-solid reaction, reaction was occur at the particle surface The particle shrinks is disappears as reaction progress because of the particle ore react with acid and giving the leachate product as shown in figure 2.

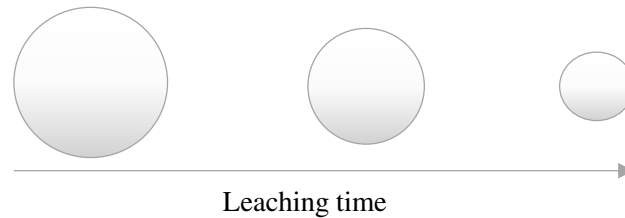

Figure 2. Illustration mechanisms of leaching shrinking core model [8], [9].

2.2. Simulation of leaching process from literature.

After crushing and grinding, the most common method to recover gold from ores is to leach gold with a sodium cyanide (NaCN) solution and oxygen. The mixtures is fed into large mechanically stirred tanks where it is agitated with air as a leaching process to form the leachate (gold-cyanide complex). The mixtures is fed into large mechanically stirred tanks where it is agitated with air as a leaching process to form the leachate (gold-cyanide complex). The air provides dissolves oxygen for gold leaching process to supplies moderate stirring power, which forces better contact between reactant and ensuring that the pulp at the bottom of tank does not heap up together [10]. Figure 3 shows that leaching process between ores, aqueous solution and air in software.

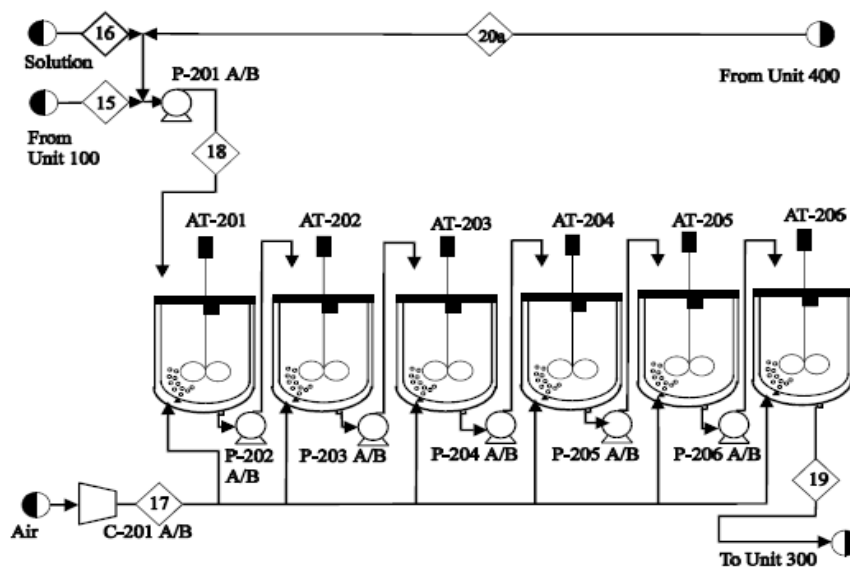

Figure 3. Leaching process of gold.

3. Methodology

In this study, cyanide had been used as a leaching reagent for gold leaching process. The feed composition used in the HSC simulation was ores (Au) = 0.15 kg/hr, O₂ = 113.45 kg/hr, CN⁻ = 2.9117kg/hr, OH⁻ = 0.9519 kg/hr, Na⁺ = 4.0397 kg/hr and H₂O = 55994 kg/hr from literature. The gold cyanidation leaching process can be expressed via the following two chemical equation which employed HSC software in the simulation. This process is assumed as steady-state because it is not effected by leaching time, temperature

and no recycle process. By using the same leaching process model of validation, case study 1, case study 2 and case study 3 were carried out as sensitivity analysis.

Cyanidation process using NaCN [11]:

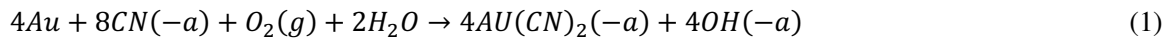

3.1. Case study 1: Chlorination for leaching process of gold

In this case study, chlorine has been used as a leaching reagent for the leaching process of gold the reaction equation for the chlorination process shown in equation 3 to compare the effect of different solvent in leaching process of gold. Chlorination process using HCl [12], [13]:

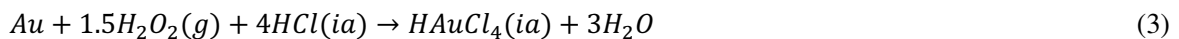

3.2. Case study 2: Effect of different concentration of Au in ores

Case study 2 is carried out to evaluate by using different amount of concentration of Au in ores with 0.5 kg/hr, 1.0 kg/hr, 1.5 kg/hr, 2.0 kg/hr, 2.5 kg/hr and 3.0 kg/hr.

3.3. Case study 3: Effect of different concentration of cyanide in solvent as a leaching reagent

The main solvent for this paper is NaCN. Case study 3 was evaluate the effect of different concentration of NaCN as a solvent in leaching process with 1.0 kg/hr, 1.5kg/hr, 2.0 kg/hr, 2.5 kg/hr, 3.0 kg/hr and 3.5 kg/hr.

4. Results and discussion

Figure 4 shows the simulation diagram and data for cyanidation leaching process of ores in HSC with steady state condition. The system of gold cyanidation is assumed to be well mixed so that the solid-liquid mass transfer resistances can be neglected. From previous studies, the most popular leaching equipment is multistage mixer-settler. It is widely used in industry because it gives a stable operation and high stage efficiency. The reactor configuration was described as a series of ideal continuous stirred tank reactor (CSTR).

4.1. Simulation of gold cyanidation leaching process

First of all, results from 2 types of different software is important because outlet stream will shows the error of leaching process. From table 1, the component shows the error occur is less than 1.5% between the components. Therefore, from the results prove that HSC software can be used as one of the simulator software for production gold in leaching process.

[CYANIDATION PROCESS]

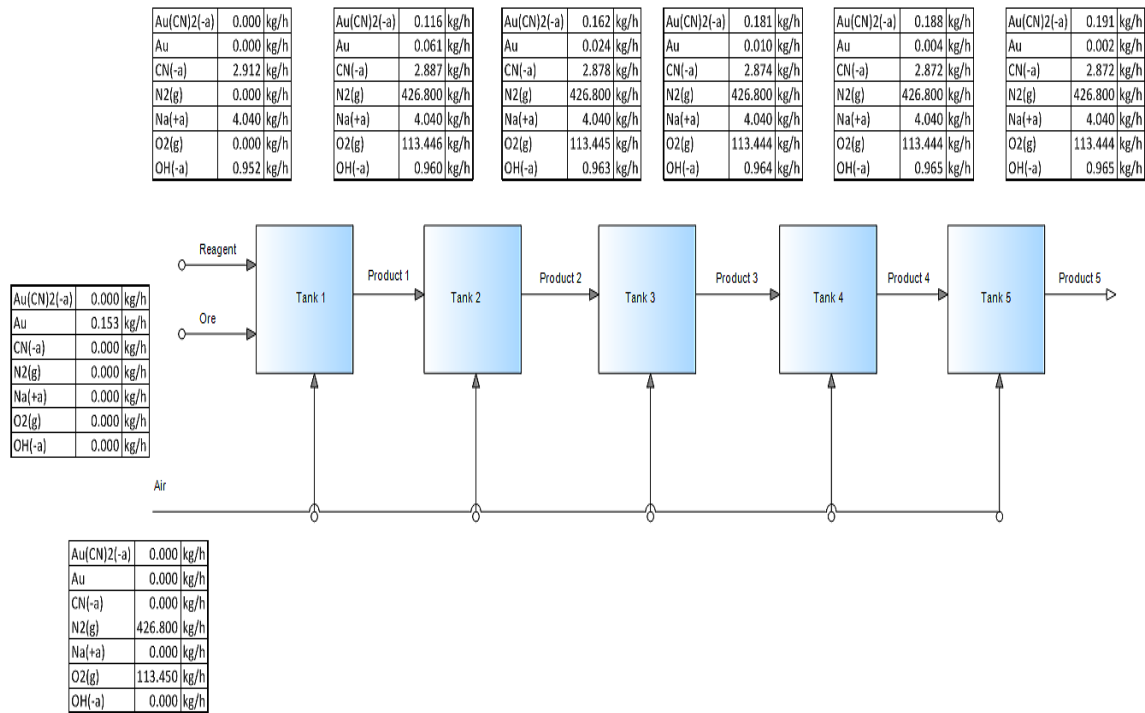
**Figure 4.** Block flow diagram of Cyanidation Leaching process by HSC.**Table 1.** Percentage of error results for cyanidation from Aspen Plus in literature and HSC simulation.

Component	Outlet stream (kg/hr)		
	From Literature	HSC Chemistry 8 (This work)	Error%
Au	0.0019	0.002	0.050
O ₂	113.45	113.45	0.000
CN ⁻	2.8719	2.872	0.003
OH ⁻	0.9519	0.952	0.001
Na ⁺	4.0397	4.040	0.007
Au(CN) ₂ ⁻	0.1907	0.188	1.416
H ₂ O	55994	55993.99	0.000
N ₂	426.80	426.80	0.000

4.2. Results for case study 1: Chlorination of leaching process of gold

Figure 5 illustrate block flow diagram of leaching process by using different solvent which is HCl in HSC. Although for this 2 process under similar test conditions for fed parameter, the result shows differences amount of Au dissolved with differences solvent which are NaCN and HCl. However, the results shows outlet stream towards leachate gold was increase at each tank refer Table 2 and Figure 6. This increment due to the continuous leaching process from one tank to another tank by sodium cyanide. Next, chlorination process shows higher Au dissolved in every tank compared to Au dissolved by cyanidation process because of strong halohydric acid such as HCl and certain amount of hydrogen peroxide can increase the dissolution rate [14]. Moreover, gold dissolves readily stable in aqueous solution in the presence of an appropriate oxidizing agent to form the tetrachloroauric ion and tetrabromoauric ion. This ion can be isolated as a hydrated acid. But, difference with iodine process which is AuI_4^- ion cannot be prepared from aqueous solution because of partial reduction to AuI_2^- take place. Beside chlorination process, another halides also can be remarks to use in gold leaching process such as bromine. The weight loss of gold strips immersed in different chloride-hypochlorite mixtures was much faster than achieved by cyanidation [15]. However, NaCN is extremely used in extraction of gold from ores because of the very stable linear cyano complexed formed with these metals. The molecular bonding for gold complexes $[:N\equiv C-Au-C\equiv N:]^-$ [13].

[CHLORINATION PROCESS]

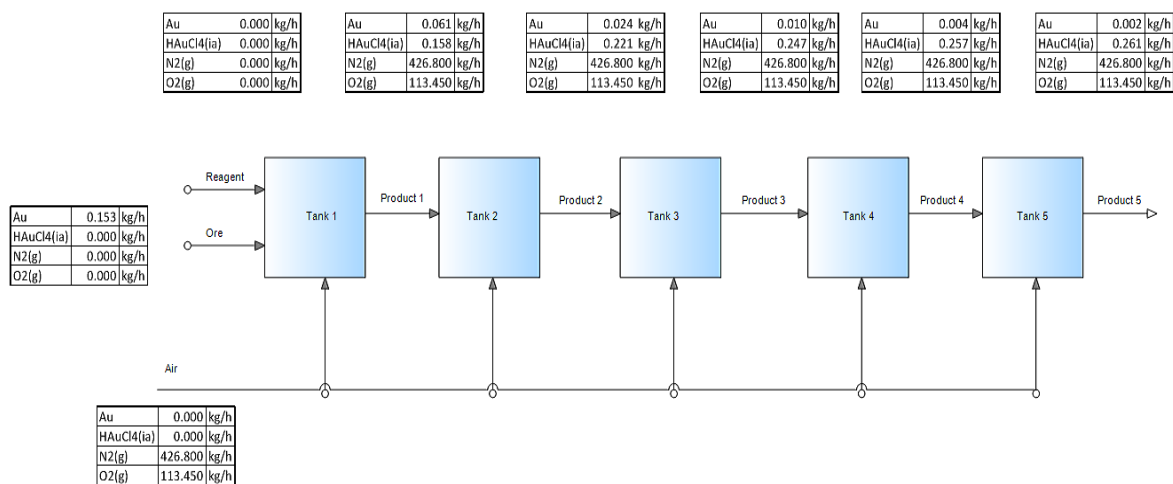

Figure 5. Block flow diagram of Chlorination Leaching Process in HSC.

Table 2. Results for Au dissolved with difference solvent.

Tank	Au dissolved with difference solvent (kg/hr)	
	NaCN	HCl
Tank 1	0.116	0.158
Tank 2	0.162	0.221
Tank 3	0.181	0.247
Tank 4	0.188	0.257
Tank 5	0.191	0.261

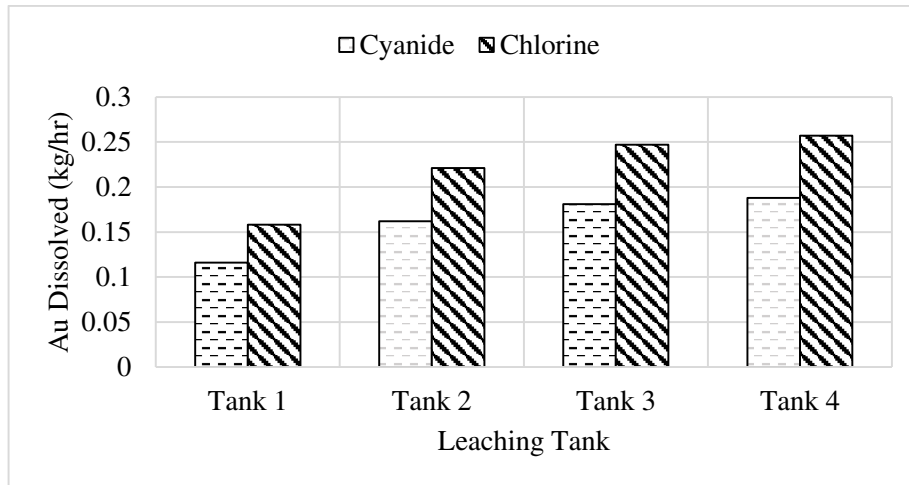

Figure 6. Gold had been dissolved with different acid such as cyanide and chlorine by leaching tank.

4.3. Results for case study 2: Effect of different flowrate of Au in ores.

The effects of flowrate in outlet stream of leachate gold was determined by varying the flowrate of feed ores (Au) from 0.5kg/hr to 3.0kg/hr. Table 3 shows that the increases of feed Au causes outlet stream of leachate gold were increased at every tank. Besides that, an increases of feed Au generate the larger difference between every tank. It is due to the rate of a chemical reaction decline by decreasing the surface area of a ores. It can be handle if the ores more go through grinding it into a powder size. So that, more particles are exposed to the acid, more collisions and the rate of reaction increases. Moreover, the rate of extraction was strongly dependent on the stirring speed of mixer settler and the value of rate constant (k) because a reaction mechanism were control by film diffusion pre-dominant [1].

Table 3. Results for outlet stream of leachate gold with different flowrate in ores.

Feed Au (kg/hr)	Outlet stream of leachate gold (kg/hr)				
	Tank 1	Tank 2	Tank 3	Tank 4	Tank 5
0.5	0.379	0.531	0.5923	0.616	0.626
1.0	0.759	1.062	1.183	1.232	1.251
1.5	1.138	1.593	1.775	1.848	1.877
2.0	1.517	2.124	2.367	2.464	2.502
2.5	1.896	2.655	2.958	3.080	3.128
3.0	2.276	3.816	3.550	3.695	3.754

4.4. Results for case study 3: Effect of different concentration of cyanide in solvent as a leaching reagent.

The cyanide concentration is reduced in every tank due to cyanide consumption kinetics (Refer table 4). It is because there are competitive reactions which consume a large amount of cyanide taking place during leaching process. As a knowledge, the reaction rate depends on the cyanide concentration in the liquid bulk and oxygen concentration at the reacting surface. In addition, gold extraction increases with increasing cyanide concentration but when maximum of gold extraction is achieved the excess cyanide it has no effect [13].

Table 4. Results for effect of different concentration of solvent as a leaching reagent.

Feed Cyanide (kg/hr)	Outlet stream of acid concentration (kg/hr)				
	Tank 1	Tank 2	Tank 3	Tank 4	Tank 5
1.0	0.976	0.966	0.962	0.961	0.960
1.5	1.476	1.466	1.462	1.461	1.460
2.0	1.976	1.966	1.962	1.961	1.960
2.5	2.476	2.466	2.462	2.461	2.460
3.0	2.976	2.966	2.962	2.961	2.960
3.5	3.476	3.466	3.462	3.461	3.960

5. Conclusion

The leaching process of gold using cyanidation and chlorination very useful for this process. Both of them shows good value for Au dissolved. The simulation model developed for gold leaching by using HSC has proven successfully performance process. Besides leaching process, oxidative chloride leaching and chlorination process has been used as pretreatment processes to oxidise carbonaceous ores prior to convention cyanidation and carbon in pulp technology [2]. In a way to improvise gold recovery method, direct gold recovery was required in gold dissolution of halides demonstrated [15]. Chlorination process also appear to be the option to replace cyanide. However, in the hydrometallurgical leaching process of gold ores by cyanidation or chlorination, the lixiviant and the chemical still highly hazardous chemicals [12].

Acknowledgments

The authors appreciate the Ministry of Higher Education Malaysia for awarding the Fundamental Research Grant Scheme (FRGS) RDU160123 and Universiti Malaysia Pahang for Post Graduate Research Scheme (PGRS 180345) for the financial assistance provided to complete this project.

References

- [1] Fleming C A and Nicol M J 1984 *J. South African Inst. Min. Metall.* **84** pp 85-93
- [2] Andrade Lima L R P 2007 Dynamic Simulation Of The Carbon-In-pulp and Carbon-In-Leach Processes *Brazilian J. of Chemical Eng.* **24** pp 623–635
- [3] Hilson G and Monhemius A J 2006 *J. Clean. Prod.* **14** 1158-1167
- [4] Mineral Policy Center 2000 “Cyanide Leach Mining Packet”. Retrieved from https://earthworks.org/cms/assets/uploads/archive/files/publications/Cyanide_Leach_Packet.pdf
- [5] Keskinen S 2013 “Thesis: Comparison of Cyanide and Thiosulphate Leaching for Gold Production (A Literature Review)” *Lappeenranta University of Technology* p 48
- [6] Petri Kobylin T and Kotiranta 2014 “43. Sim Reactions (Hydro) Unit” **1**(15)
- [7] Crundwell F K and Godorr S A 1997 *Hydrometallurgy* **44** 147–162
- [8] Othusitse N and Muzenda E 2015 “Predictive Models of Leaching Processes: A Critical Review” *7th Int. Conf. Latest Trends Eng. Technol. Nov. 26-27, 2015 Irene, Pretoria South Africa*, 136-141
- [9] Safari V, Arzpeyma G, Rashchi F, and Mostoufi N 2009 *Int. J. Miner. Process.* **93** 79–83
- [10] Jun Z, Zhi-zhong M, Run-da J, and Da-kuo H 2015 *Miner. Eng.* **70** 250–263
- [11] Habashi F 2007 *Chem. Prod. Process Model.* **2** 1-24
- [12] Tao Y X and Sun Y 1998 *NASA Conf. Publ.* **2** 43
- [13] Ketcheson K and Fingas M 1994 *Environ. Technol.* 1-22
- [14] La Brooy S R, Linge H G and Walker G S 1994 *Miner. Eng.* **7** 1213-1241
- [15] Aylmore M G 2016 *Gold Ore Processing: Project Development and Operations* (Singapore: Elsevier) (Second Edition) Chapter 27 p 447-484