

A Study on The Development of Local Exhaust Ventilation System (LEV's) for Installation of Laser Cutting Machine

S. I. Harun, S. R. A. Idris*, N. Tamar Jaya

Faculty of Mechanical Engineering, Universiti Malaysia Pahang, 26600 Pekan, Pahang, Malaysia.

E-mail: rabiattull@ump.edu.my

Abstract. Local exhaust ventilation (LEV) is an engineering system frequently used in the workplace to protect operators from hazardous substances. The objective of this project is design and fabricate the ventilation system as installation for chamber room of laser cutting machine and to stimulate the air flow inside chamber room of laser cutting machine with the ventilation system that designed. LEV's fabricated with rated voltage D.C 10.8V and 1.5 ampere. Its capacity 600 ml, continuously use limit approximately 12-15 minute, overall length LEV's fabricated is 966 mm with net weight 0.88 kg and maximum airflow is 1.3 meter cubic per minute. Stimulate the air flow inside chamber room of laser cutting machine with the ventilation system that designed and fabricated overall result get 2 main gas vapor which air and carbon dioxide. For air gas which experimented by using anemometer, general duct velocity that produce is same with other gas produce, carbon dioxide which 5 m/s until 10 m/s. Overall result for 5 m/s and 10 m/s as minimum and maximum duct velocity produce for both air and carbon dioxide. The air gas flow velocity that captured by LEV's fabricated, 3.998 m/s average velocity captured from 5 m/s duct velocity which it efficiency of 79.960% and 7.667 m/s average velocity captured from 10 m/s duct velocity with efficiency of 76.665%. For carbon dioxide gas flow velocity that captured by LEV's fabricated, 3.674 m/s average velocity captured from 5 m/s duct velocity which it efficiency of 73.480% and 8.255 m/s average velocity captured from 10 m/s duct velocity with efficiency of 82.545%.

1. Introduction

Local exhaust ventilation (LEV) is an engineering system frequently used in the workplace to protect operators from hazardous substances [1]. To have an effective system it is important that it is well designed and installed, used correctly and properly maintained. Study this case and work on it with design and development to provide an effective system. Common problems nowadays are supervisor are often unaware their operators are being over-exposed to hazardous substances or that existing controls may be inadequate [2]. Besides that, sources of exposure are missed and the supervisor (and suppliers) are over-optimistic about the effectiveness of the controls. Moreover, existing controls have deteriorated also controls are not used correctly [3]. Need to work and study on designing and developing LEV system to avoid expensive mistakes and to control exposure effectively. Must provide LEV that is fit for purpose, is shown to work and continues to work. Ensure controls are adequate. Together with help of supervisor discuss on project must be competent in the operation of the LEV system [4].

Laser cutting is a technology that uses a laser to cut materials, and is typically used for industrial manufacturing applications, but is also starting to be used by schools, small businesses, and hobbyists [5]. Generation of the laser beam involves stimulating a lasing material by electrical discharges or



lamps within a closed container [6]. As the lasing material is stimulated, the beam is reflected internally by means of a partial mirror, until it achieves sufficient energy to escape as a stream of monochromatic coherent light. Mirrors or fiber optics are typically used to direct the coherent light to a lens, which focuses the light at the work zone [7]. Thermal effects are the predominant cause of laser radiation injury, but photo-chemical effects can also be of concern for specific wavelengths of laser radiation. Even moderately powered lasers can cause injury to the eye. High power lasers can also burn the skin. Some lasers are so powerful that even the diffuse reflection from a surface can be hazardous to the eye [8]. Argon-ion lasers emit light in the range 351–528.7 nm. Depending on the optics and the laser tube a different number of lines is usable but the most commonly used lines are 458 nm, 488 nm and 514.5 nm. Laser line filters are narrow bandpass filters centered on the resonance of the laser, which attenuate the background plasma and secondary emissions that often result in erroneous signals [9].

2. Experimental Procedure

2.1. Design the selected LEV's

A specification should be drawn up for the operator's review. The specification should consider the work processes, the operator involved, the potential fugitive dusts/fumes/gases and the likely sources or points of exposure. It is critical that all exposure points are identified so that the specification is accurate and expensive retro-fitting is avoided. The thoroughness of the risk assessment in initially identifying the areas where control is needed is fundamental to ensuring the installation of an effective LEV system. Regardless of whether the installation is likely to be simple or complex, discuss with supervisor who know his process, should work closely with any supervisor or lecturer to achieve an effective LEV design. Simple design process can be explained, which select the potential supplier who provided best LEV's. For supplier, should prepare design and quotation on exhaust the air contaminant from being exposed to operator. Then the supplier selected the author as well selected great design LEV's plus provided prototypes before deciding whether selected it or not. Figure 1 shows the design selected LEV's that satisfy properly which will collect the air that contains the contaminant (close to the source), make sure they are contained and taken away from people and clean the air and get rid the contaminant safely.

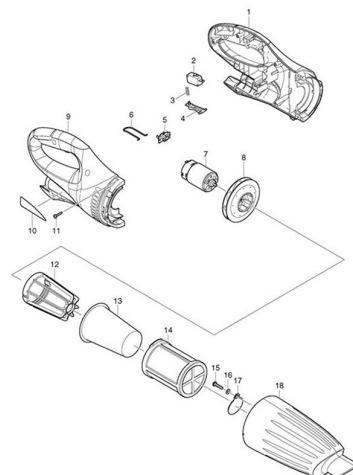

Figure 1. LEV System in Exploded View Spare Parts Model 10.8V LXT Cordless Air blower.

2.2. Experiment and Simulation on Design Selected LEV's

LEV is a ventilation system that collects and sucks out particles such as dusts, mists, gases, vapors or fumes out of work station, so that they can't be breathed in by occupants. To overcome this issue, SolidWorks will be implemented. Past studies SolidWorks techniques represent a very significant improvement of air ventilation systems. However, SolidWorks is just a tool in prediction model, which can lead to inaccuracy of predicting airflow due to problems with pre-processing, solver and post-processing with parameter from actual experimental results [10]. Yet, it is not possible to 100% accurately simulate airflow around a body [11]. These codes are simply models which are close to that of a real flow, but not an exact match. These require validation to help minimizing percentage error in SolidWorks methodology. Several strategies are needed to boost effectiveness of LEV in terms of predicting airflow in a geometry model [12]. The outcome of this research can be used as a benchmark or guideline for industries to help improving indoor air quality (IAQ). Figure 2 shows that the anemometer selected use for to do an experiment sample of duct or gas vapor produced by a laser which detect and measure the general duct or smoke velocity produced by laser inside whole chamber room that include operator who nearly exposed to it.



Figure 2. Mastech MS6252A Handheld LCD Digital Electronic Wind Speed Meter Anemometer Lock Function Digital Anemometer.

3. Results and Discussion

3.1. Bulk Microstructural Analysis

Given general duct velocity for smoke or fumes produced by laser 5-10 m/s, for air and carbon dioxide (CO₂) which can be consider as general produced by laser in 5-10 m/s take as experiment for simulation as result in Figure 3 and Figure 5. Table 1 and Table 2 shows that to get how given designed made for LEV flow inside it and take velocity on air flow take in time to exhaust to outside surrounding workplace and then record in table below shows that after taking general air and carbon dioxide (CO₂) velocity 5-10 m/s, being captured and velocity that air and carbon dioxide flow to be exhausted to outside surrounding workplace and take time for it. Then, proceed to identify the efficiency of LEV's to capture the all the duct or smoke for both air and carbon dioxide gases. Figure 4 and figure 6 shows that increases indicated velocity in graph by air and CO₂ produced and captured and the gradient from both graph can be determined as efficiency of LEV's and then compare data given efficiency either satisfy for operator being safe from exposed hazard contaminant with at least 70- 90% efficiency.

Table 1. Air Flow Velocity Captured Given Air Dust Velocity Produced by Laser.

Air Velocity (m/s)	Air Flow Velocity Captured				
	Minimum Velocity (m/s)	Maximum Velocity (m/s)	Time (s)	Average Velocity (m/s)	Efficiency (%)
5	0.800	7.196	5.480	3.998	79.960
6	0.943	8.488	5.800	4.716	78.592
7	1.186	10.672	6.320	5.929	84.700
8	1.204	10.839	6.760	6.022	75.269
9	1.380	12.422	7.600	6.901	76.678
10	1.533	13.800	9.280	7.667	76.665

Air Duct/Smoke

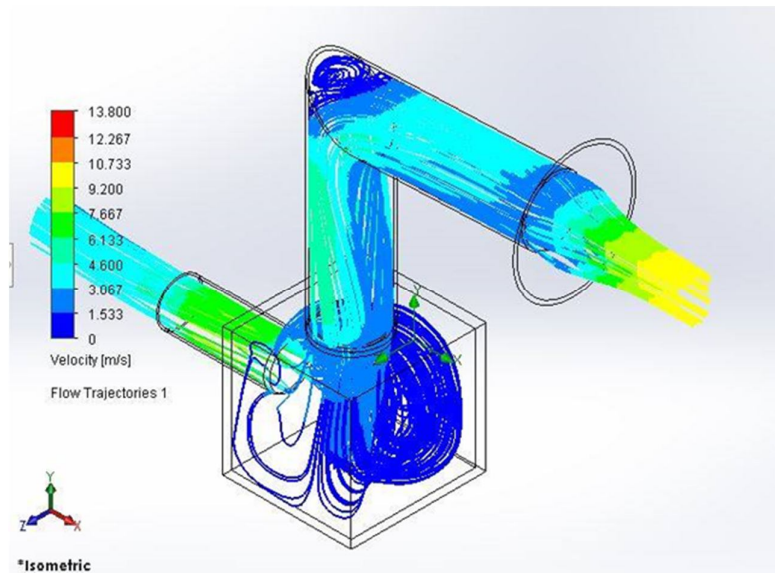

Figure 3. Air flow Simulation in LEV System Designed with indicates the maximum and minimum air velocity captured by LEV's.

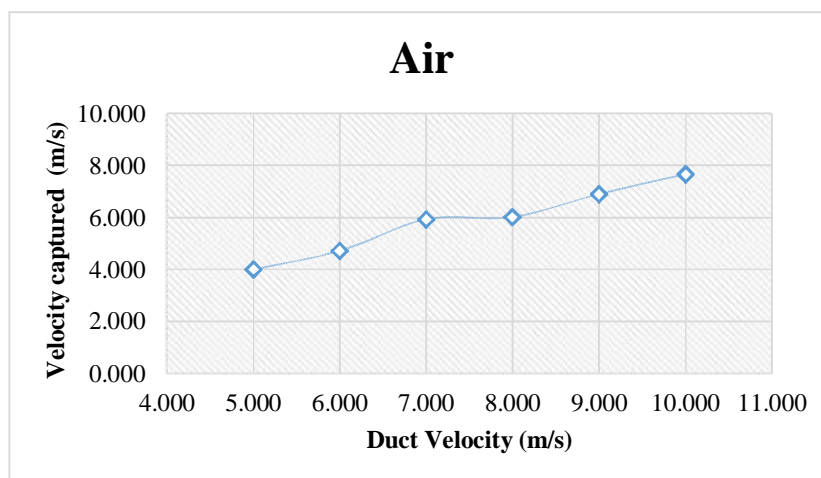

Figure 4. Graph of Air Duct velocity captured versus air duct velocity produced by laser.

Table 2. CO2 Flow Velocity Captured Given CO2 Dust Velocity Produced by Laser.

Carbon Dioxide (CO2) Velocity (m/s)	Carbon Dioxide (CO2) Flow Velocity Captured				
	Minimum Velocity (m/s)	Maximum Velocity (m/s)	Time (s)	Average Velocity (m/s)	Efficiency (%)
5	0.735	6.613	3.720	3.674	73.480
6	0.922	8.302	4.080	4.612	76.867
7	1.092	9.831	5.400	5.462	78.021
8	1.272	11.447	6.880	6.360	79.494
9	1.435	12.918	7.000	7.177	79.739
10	1.651	14.858	8.720	8.255	82.545

Air Duct/Smoke

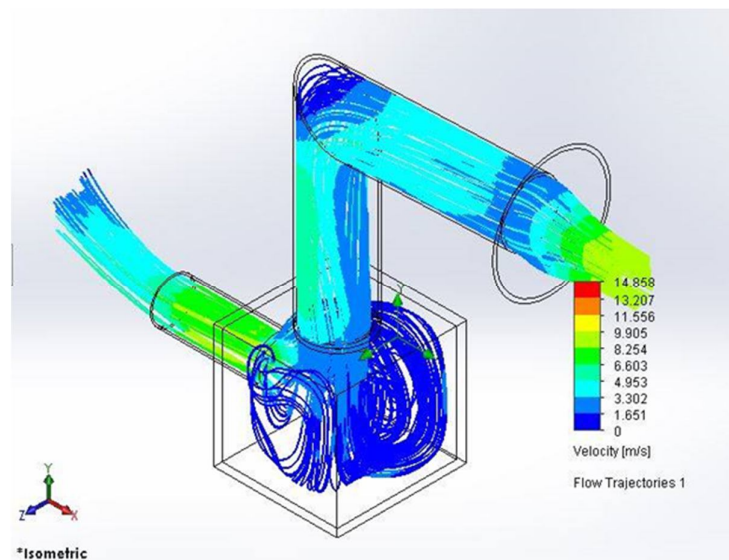

Figure 5. Carbon Dioxide Flow Simulation in LEV System Designed.

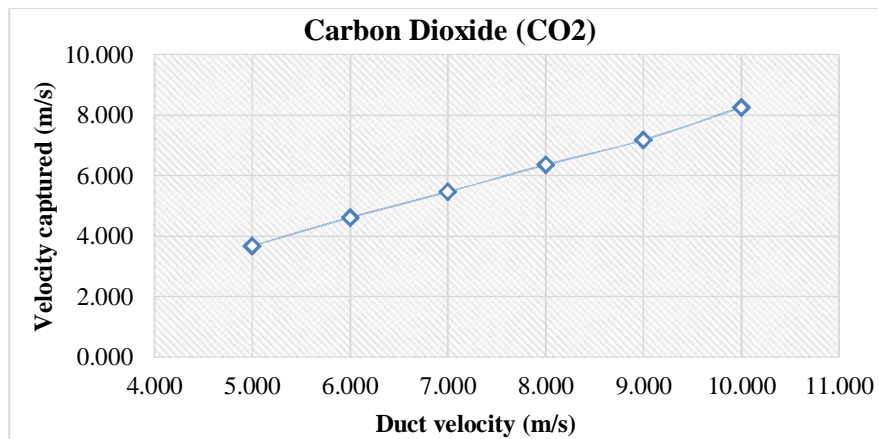

Figure 6. Graph of Carbon Dioxide (CO2) Dust velocity captured versus CO2 duct velocity produced by laser.

4. Conclusion

As conclusion, design the cordless local exhaust ventilation system and it with successfully installed at chamber room of laser cutting machine. LEV's fabricated with rated voltage D.C 10.8V and 1.5 ampere. Its capacity 600 ml, continuously use limit approximately 12-15 minute, overall length LEV's fabricated is 966 mm with net weight 0.88 kg and maximum airflow is 1.3 meter cubic per minute. Stimulate the air flow inside chamber room of laser cutting machine with the ventilation system that designed and fabricated overall result get 2 main gas vapor which air and carbon dioxide. For air gas which experimented by using anemometer, general duct velocity that produce is same with other gas produce, carbon dioxide which 5 m/s until 10 m/s. Overall result for 5 m/s and 10 m/s as minimum and maximum duct velocity produce for both air and carbon dioxide. The air gas flow velocity that captured by LEV's fabricated, 3.998 m/s average velocity captured from 5 m/s duct velocity which it efficiency of 79.960% and 7.667 m/s average velocity captured from 10 m/s duct velocity with efficiency of 76.665%. For carbon dioxide gas flow velocity that captured by levs fabricated, 3.674 m/s average velocities captured from 5 m/s duct velocity which it efficiency of 73.480% and 8.255 m/s average velocity captured from 10 m/s duct velocity with efficiency of 82.545%.

Acknowledgement

All experimental works were done in Joining and Welding lab, Faculty of Mechanical Engineering, UMP.

References

- [1] Yu H, Cheng W, Wu L, Wang H and Xie Y, Mechanisms of dust diffuse pollution under forced-exhaust ventilation in fully-mechanized excavation faces by CFD-DEM *Powder Technology* 2017 317 31-47
- [2] Ahmed A Q, Gao S, and Kareem A K, Energy saving and indoor thermal comfort evaluation using a novel local exhaust ventilation system for office rooms *Applied Thermal Engineering* 2017 110 821-834
- [3] Arghand T, Taghi K, Hazim A and Mathias C, An experimental investigation of the flow and comfort parameters for under-floor, confluent jets and mixing ventilation systems in an open-plan office *Building and Environment* 2015 92 48-60
- [4] Croitoru, C, Bode F, Nastase I, Sandu M, Vasilescu A and Tacutu L, General Ventilation System Optimization Study for Environment Improvement of Sludge Dewatering Area from a Wastewater Treatment Plant *Energy Procedia* 2017. 112 640-649
- [5] Zhao J. and Cheng P, A lattice Boltzmann method for simulating laser cutting of thin metal plates *International Journal of Heat and Mass Transfer* 2017 110 94-103
- [6] Shin J S, Oh S Y, Park, H, Chung C M, Seon S, Kim T-S, Lee L, Choi B-S and Moon J-K, High-speed fiber laser cutting of thick stainless steel for dismantling tasks. *Optics & Laser Technology*, 2017. 94: p. 244-247
- [7] Guerra A J, Farjas J, and Ciurana J, Fibre laser cutting of polycaprolactone sheet for stents manufacturing: A feasibility study *Optics & Laser Technology* 2017 95 113-123
- [8] Schleier M, Adelmann B and Neumeier B, Burr formation detector for fiber laser cutting based on a photodiode sensor system *Optics & Laser Technology* 2017 96 13-17
- [9] Samarjy R S M and Kaplan A F H, Using laser cutting as a source of molten droplets for additive manufacturing: A new recycling technique *Materials & Design* 2017 125 76-84
- [10] Hunt G R and Ingham D B, 03 O 03 A 3-dimensional axisymmetric model of the air flow pattern created by a local exhaust ventilation system reinforced by a turbulent radial jet flow *Journal of Aerosol Science* 199. 24 S15-S16
- [11] Varghese R J, Kishore V R V, Akram M, Yoon Y and Kuma Burning velocities of DME (dimethyl ether)-air premixed flames at elevated temperatures *Energy*, 2017 126 34-41
- [12] Putra R N and Ajiwiguna T A, Influence of Air Temperature and Velocity for Drying Process *Procedia Engineering* 2017 170 516-519