

A Monitoring System for EPW Safe Use

M. H. ALSIBA^{1*}, N. N. N. Hamran¹, Abdul Nasir¹ and A. A. Abdullah²

¹Faculty of Engineering Technology, University Malaysia Pahang, Gambang - Kuantan, Malaysia.

²Automotive Engineering Centre, University Malaysia Pahang, Pekan, Malaysia.
*mhdhayyan@gmail.com

Abstract— Electric Powered Wheelchair (EPW) can be considered as a special Electric Vehicle (EV) because it is used by senior citizens, disabled drivers/users who have special needs. Using manual or electric wheelchair independently rises up an important problem which is the lack of user monitoring. Wheelchair users are more subject to fatigue and emergency health situations. This paper presents an add-on smart monitoring system to help wheelchair users to use the wheelchair independently and safely. The system integrates health related sensors with computer, mobile phone and an alarm system. The tested prototype uses two sensors, namely, temperature sensor and heart beat sensor. The system is extendable and more sensors can be added. The temperature sensor is used to sense the body temperature which is a basic parameter for monitoring and diagnosing human health. Heartbeat sensor is used to measure the user Mean Arterial Pressure (MAP). It can be connected to a personal computer to show the cardiograph. Body temperature and MAP data are acquired by an embedded system and displayed on a Liquid Crystal Display (LCD). Data are also sent to the cloud for Internet of Things (IoT) monitoring. In emergency cases alarm signal is triggered. Moreover, a notification Email and SMS messages are sent to the people in charge of monitoring the user. The system was tested and validated as a real-time monitoring system.

Index Terms— EV; Health Care; Driver Safety, IoT, Embedded System, Smart Wheelchair.

I. INTRODUCTION

Approximately, 10% of the global population, i.e. around 650 million people have disabilities [1]. 200 million of them are children. UNICEF report about the situation in Malaysia, stated that in 2012 around 445,000 people with disabilities were registered voluntarily [2]. Studies indicate that globally around 10% of the disabled people require a wheelchair [3]. Many wheelchair users would like to use it independently. However, it was estimated that 20 million of those requiring a wheelchair for mobility do not have one. There are indications that only a minority of those in need of wheelchairs have access to them, and very few of these people have access to an appropriate wheelchair [3].

According to our survey, wheelchair users tend to use wheelchairs independently. However, many users cannot move the wheelchair by their own and need to wait for a helper to push them. To solve the problem, Electric Powered Wheelchair (EPW) are used. Many researchers have suggested more advanced solutions which might be categorized under the title “smart wheelchair systems”. Wheelchairs are considered smart systems according to: Human – machine interface, the navigation methods and other smart systems like safety driving systems [4].

Wheelchair users usually have health complaints. Moreover, there is a fast growing in elderly (65+)

population worldwide. Consequently, the number of wheelchair users requiring continuous monitoring has been also increased. However, the frequency of obtaining health related measurement in hospitals depends on the situation of the patient and the medical care staff judgment. For example, primary stroke centers acquire data every 15 minutes and intensive care units require a minimum of hourly data record [5]. Therefore, it is not always safe to use a wheelchair independently. Wheelchair users are more subject to fatigue and emergency health situation. Therefore, an add-on monitoring system is needed to help the family or nurses to be aware in any case of emergency. A proposed monitoring system is explained in this paper.

Many systems for health and vital-sign monitoring are proposed in research literature. The systems use different kind of platforms like: Internet based monitoring, GSM-SMS protocols, Wireless Sensor Networks (WSN), Bluetooth, WiFi, and Radio Frequency (RF). Most recent systems are shifted more toward computer and smartphones based applications [5]. However, most of the health related systems are applying the Mobile Health (m-Health) concept, which is the use of mobile phones and other wireless technologies for the medical care. The most common application of m-Health is to educate consumers about preventive health care services. Moreover, there are Apps for physical activity, anti-obesity, diabetes self-management and asthma self-management [5].

Android devices are very popular nowadays and can be used for many powerful controlling applications like the applications listed in [6][7]. Applications include robot operating, home appliances remote controlling, security, safety, employee monitoring systems and industrial systems. Android based health monitoring and reporting systems are also taking more concern [8]. The structure of most of these systems includes a smartphone which communicates with a controller [9] [10]. Some researchers combine different technologies. For example, WSN and cloud computing services are integrated in [11].

In this paper, a smart monitoring system which combines sensors, smartphone and Micro-Controller Unit (MCU) is proposed. This system guarantees a comprehensive monitoring for the EPW user. The vital-sign data are displayed on a Liquid Crystal Display (LCD). Data are also sent to the cloud using “dweet.io” service to be available for Internet of Things (IoT) monitoring. Moreover, a USB cable can be used to connect the MCU to a personal computer. The personal computer is used to demonstrate the cardiograph if needed. SMS and/or Email messages are sent in emergency cases using an Android App which is developed using “Magnet Code” smartphone controller platform [12]. HC-06 Bluetooth communication module is used to connect the smartphone with the MCU. A detailed

description of the system is provided in next section.

II. SYSTEM DESIGN

The proposed system is an add-on device to be integrated as a part of a more general smart EPW project. The general architecture of the project is shown in Figure 1.



Figure 1: The general smart EPW system.

The project comprises two phases. First phase aims at designing a conversion kit which is cheap, adjustable, customizable and practically designed according to the needs of wheelchair users. Using a manual or EPW independently rise up a problem which is the lack of patient monitoring. To solve this problem, the proposed add-on system in second phase aims to provide a remote monitoring system for wheelchair users using the IoT concept. This paper discusses the second phase of the project.

Figure 2 shows an overview diagram of the monitoring system. For testing purpose a simple prototype which comprises two essential sensors is presented in this paper. First sensor is to measure body temperature which is basic parameter for monitoring and diagnosing human health. Heartbeat sensor is used to measure heartbeat rate and the patient/user Mean Arterial Pressure (MAP). In this project SEN-11574 heart sensor is a used. The sensor is based on the principle of photo plethysmography. It measures the change in volume of blood through any organ of the body of user which cause the changes occur in the light intensity through the vascular region of the organ. The signal pulses

are same as the heart rate pulses.

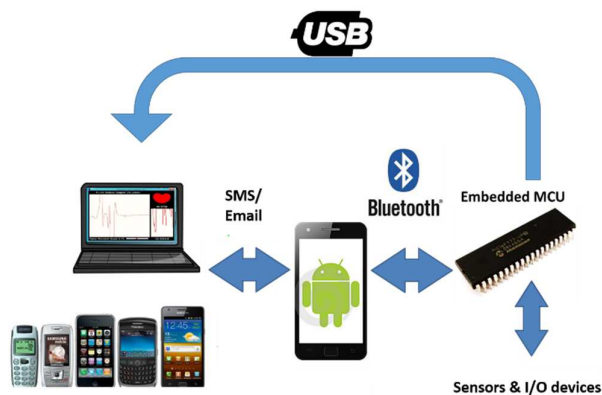

Figure 2: The monitoring system overview diagram.

Temperature sensor and heartbeat pulse sensor provide analogue signals which are the input for the controlling unit. The MCU converts the input data from both sensors to digital values. The values are showed on a 2×16 LCD module as shown in Figure 3. Moreover, the system can be connected to a computer/laptop to draw the cardiograph as shown in Figure 4.



Figure 3: Sensor readings are shown on LCD.

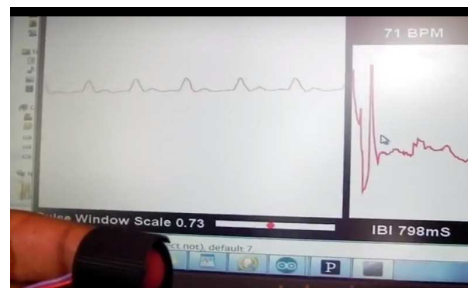

Figure 4: Plotting the cardiograph on a laptop screen.

Figure 5 shows the flowchart of the monitoring system. The MCU continuously reads the temperature T and heartbeat pulse rate Hb of a user. The reading results are shown on the LCD and optionally the cardiograph can be shown on the computer/laptop. The system will trigger an alarming sound if the condition of body temperature and heart pulses of a user are abnormal. The temperature is considered normal if T is in the range: $36^{\circ}\text{C} < T \leq 38^{\circ}\text{C}$. Heartbeat rate is considered normal if Hb is in the range: $70 \text{ BPM} < Hb \leq 90 \text{ BPM}$. The alarm is triggered if T or Hb are out of these ranges. SMS and Email will be sent to designated people in charge using the mobile phone App at the same time. The smartphone snaps a photo of the scene and attach it to the Email.

Figure 6 shows the system prototyping circuit using Arduino Uno. The monitoring system, which includes the

MCU, the sensors, the LCD and the Bluetooth module as one integrated device, can be installed to any wheelchair as a standalone add-on device. The installation of the prototype is shown more clearly in Figure 7. It is powered directly from the EPW 48V battery using the chip LM2596HV which is a 3A step-down voltage regulator.

To send the information through Email and SMS, MCU needs to communicate with user's smartphone. Communication is done by sending commands and receiving information from the phone. "Magnet Code" platform [12] provides the developers with a set of basic features and components to build the needed Android App. The basic features include: title bar setting, responsive LCD with vertical scroll bar, responsive buttons, background setting and command box. In addition to the previous basic components, developers can use a set of toolboxes as shown in Figure 8. The list of tool boxes includes: Audio Toolbox, Sensor Toolbox, Photo Toolbox, Video Toolbox, Email Toolbox, SMS Toolbox, and Database Toolbox.

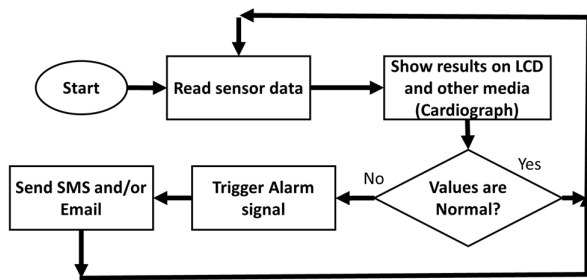

Figure 5: The monitoring system working flowchart.

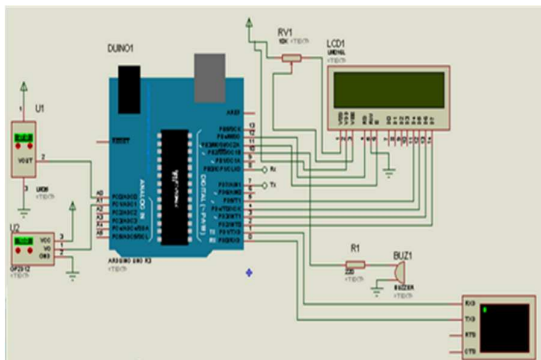

Figure 6: System circuit.



Figure 7: The installation of the monitoring system.

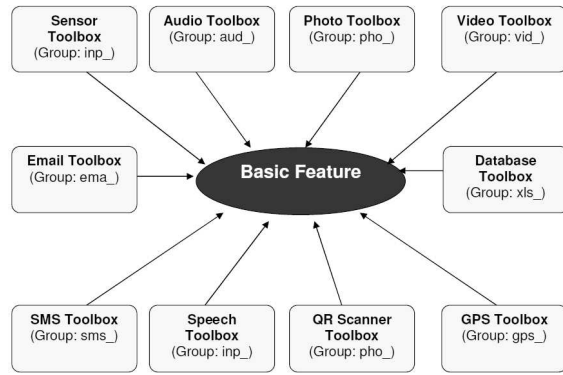

Figure 8: "Magnet Code" features and toolboxes.

The commands to be sent by the MCU have a special format [12]:

Group name (3 bytes) + _ + Sub Command 1 (3 bytes) + Sub Command 2 (1 to 3 bytes) + <value> (optional, accept '#' as enter or data splitter) + \r\n

The commands are sent from the MCU using the command "printf" as follows:

```

    Printf("out_vibon\r\n");
    Printf("lcd_shotex<Hello!>\r\n");
  
```

```

    Printf("vid_froman<myfile%u>\r\n",count1);
    Printf("aud_plaon<myfile%lu>\r\n",count2);
  
```

MCU gets the information from the smartphone using the command "getch()":

```

    void serial_isr()
    { data1=getch(); //this is data we want
      data2=getch(); //carriage return or \r or 0x0D
      data3=getch(); //new line or \n or 0x0A
      if(data3==0x0A)
      { run=2; } }
  
```

"Magnet Code" provides an "Email Setting" and "SMS Setting" graphical interfaces which are used to set the receiver details, Email and SMS content, subject, and Email attachments. The Email setting graphical interface is shown in Figure 9.

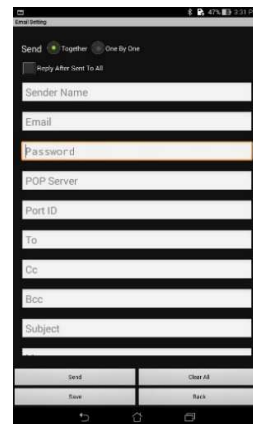

Figure 9: Email setting graphical interface.

Photo Toolbox of “Magnet code” receives command from the MCU to snap the photo. Figure 10 shows an example of the sent Email.

The Database Toolbox is used for data logging. The logged data are saved to a file on the smart phone. Meanwhile, data are sent to the cloud using “dweet.io” service. The data are provided for IoT continuous monitoring using “Freeboard” dashboards as shown in Figure 11.

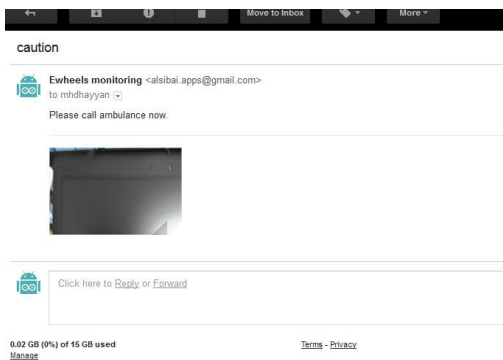

Figure 10: Example of the sent Email.

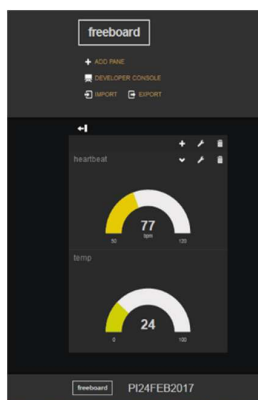

Figure 11: Freeboard as an example of IoT dashboards.

III. RESULTS

The proposed monitoring system was implemented in real modes by setting the following experiment. Four students in our laboratory were volunteered to help in the experiment. To increase the heartbeat rate and body temperature, students were asked to perform jogging for around 10 - 15 minutes. The heartbeat sensor and temperature sensors are used to measure their related vital-signs before and after the jogging. The temperature is considered normal if $36^{\circ}\text{C} < T \leq 38^{\circ}\text{C}$. Heartbeat rate is considered normal if $70 \text{ BPM} < \text{Hb} \leq 90 \text{ BPM}$. Of course the thresholds can be modified according to the user case. Experiment results are summarized in Table 1.

From Table 1 it is clear that the system worked perfectly according to the tested scenarios. Alarming signals, Emails and SMSs were sent correctly and within one-minute after recognizing an abnormal situation. IoT monitoring dashboards kept updated correctly with less than one-minute delay. These results validate the system as a real-time monitoring system.

Table 1
Results summary.

Sensor values		System output description
Heartbeat rate (BPM)	Temperature ($^{\circ}\text{C}$)	
88	37	No Alarm / No SMS or Email / Freeboard showed correct values
107	38	Alarm was triggered after 25 sec / SMS was received after 45 sec / Email was received after 58 sec / Freeboard showed correct values
77	38	No Alarm / No SMS or Email / Freeboard showed correct values
98	38	Alarm was triggered after 30 sec / SMS was received after 49 sec / Email was received after 61 sec / Freeboard showed correct values
85	38	No Alarm / No SMS or Email / Freeboard showed correct values
123	39	Alarm was triggered after 29 sec / SMS was received after 44 sec / Email was received after 57 sec / Freeboard showed correct values
79	37	No Alarm / No SMS or Email / Freeboard showed correct values
133	40	Alarm was triggered after 25 sec / SMS was received after 45 sec / Email was received after 58 sec / Freeboard showed correct values

IV. CONCLUSION

An advanced system for independent EPW user monitoring is proposed in this study. The user monitoring system can be installed to any wheelchair to ensure the users independent and safe mobility. The system integrates an Android smartphone App, an embedded MCU and vital-signs sensors. The system uses a Bluetooth technology connection to exchange commands and data between the smartphone and MCU module. The monitoring add-on device is attached to the wheelchair in a visible way for the user. The device is powered by connecting it to the EPW main power system. Through the commands, the MCU can easily control the SMS, Email and data logging modules in the smartphone.

A temperature and heartbeat sensors are used in the current prototyping version of the device. More vital-signs sensors like respiration rate, blood pressure or even electroencephalogram (EEG) sensor can be added and integrated to the system easily. Sensor data are displayed on an LCD screen. Moreover, the data are saved to a log file on the smart phone and are continuously sent to the cloud using “dweet.io” service. The data are provided for IoT continuous monitoring using “Freeboard” dashboard.

In emergency cases alarm signal is triggered. Moreover, an alarming Email and SMS are sent to the involved people for notification. The system was tested and validated as a real-time system.

Future plans include extending the system ability for

measuring more vital-signs and improve its ability to analyze the data more efficiently. Moreover, more advanced add-on systems can be integrated with the EPW like obstacle avoidance devices.

ACKNOWLEDGMENT

The authors acknowledge Faculty of Engineering Technology and Automotive Engineering Centre – University Malaysia Pahang and Ministry Higher Education – Malaysia for supporting this research under final year project budget and FRGS grant (Ref: FRGS/1/2016/TK04/UMP/02/13).

REFERENCES

- [1] World Health Organization (WHO), World report on disability. *WHO Library Cataloguing-in-Publication Data*, 2011, 325 pages. Available on line (Last visit 8, 2017): http://www.who.int/disabilities/world_report/2011/
- [2] UNICEF, State of the World's Children, Situation in Malaysia, Children with Disabilities. 2013. Available on line (Last visit 8, 2017) https://www.unicef.org/malaysia/sowc_sowc_13-situation_in_malaysia.html
- [3] World Health Organization (WHO), Fact sheet on wheelchairs, 2010, Available on line (Last visit 8, 2017): <http://apps.who.int/iris/handle/10665/205041>
- [4] M. H. Alsibai and S. Abdul Manap, "A Study on Smart Wheelchair Systems", *International Journal of Engineering Technology and sciences (ijets)* vol. 4 (1), 2015, pp. 25 – 35.
- [5] M. M. Baig, H. Gholamhosseini, M. Linden and M. J. Connolly, "Review of Vital Signs Monitoring Systems – Patient's Acceptability, Issues and Challenges", *Neuroscience and Biomedical Engineering*, Vol 2 (1), 2014, pp. 2 - 13.
- [6] M. H. Alsibai and H. M. Siang, "A smart driver monitoring system using android application and embedded system" *In: 5th IEEE International Conference on Control Systems, Computing and Engineering (ICCSCE 2015)*, 2015, pp. 242–247.
- [7] M. H. Alsibai, H. Manap and A. A. Abdullah, "Enhanced face recognition method performance on android vs windows platform", *ARPN Journal of Engineering and Applied Sciences*, Vol 10 (23), 2015, pp. 17479 - 17485.
- [8] M. Navale, S. Damare, R. Chavan, R. Dube, and S. Patil, "Android Based Heart Monitoring and Reporting System", *International Journal of Advanced Research in Computer and Communication Engineering*, Vol 3(5), 2014, pp. 6544 - 6546.
- [9] A. R. Yeole, S. M. Bramhankar, M. D. Wan and M. P. Mahajan, "Smart Phone Controlled Robot Using ATMEGA328 Microcontroller", *International Journal of Innovative Research in Computer and Communication Engineering*, Vol 3 (1), 2015, pp. 352 – 356.
- [10] M. Puthanial, S. Rajeshwari, P. C. K. Raja and P. Shankar, "Android and Bluetooth Technology Enabled Remote Control Using Smart Phone", *International Journal of Advanced Research in Electrical, Electronics and Instrumentation Engineering*, Vol 3 (5) 2014, pp. 9373 – 9380.
- [11] N. Indumathy and D. K. K. Patil., "Medical Alert System for Remote Health Monitoring Using Sensors and Cloud Computing", *International Journal of Research in Engineering and Technology*, Vol 3(4), 2014, pp. 884-888.
- [12] Magnet Code: smartphone controller online (last visit 8, 2017): <http://www.magnetcode.com/magnetcode/>