

Composite PD and Fuzzy Logic Approach for Vibration of Elastic Joint Manipulator

Mohd Ashraf Ahmad, Raja Mohd Taufika Raja Ismail, Mohd Syakirin Ramli,

Mohd Anwar Zawawi and Mohd Helmi Suid

Faculty of Electrical and Electronics Engineering, Universiti Malaysia Pahang, Pekan, Pahang, Malaysia
(Tel : +609-424-2070; E-mail: mashraf@ump.edu.my)

Abstract: The increased complexity of the dynamics of robots manipulator considering joint elasticity makes conventional model-based control strategies complex and difficult to synthesize. This paper presents investigations into the development of composite collocated proportional-derivative (PD) and Fuzzy Logic Control for trajectory tracking and vibration control of a flexible joint manipulator respectively. To study the effectiveness of the controllers, a collocated PD Controller is developed for tip angular position control of a flexible joint manipulator. This is then extended to incorporate a non-collocated Fuzzy Logic Controller for vibration reduction of the flexible joint system. Simulation results of the response of the flexible joint manipulator with the controllers are presented in time and frequency domains. The performances of the composite control schemes are examined in terms of input tracking capability, level of vibration reduction and time response specifications. Finally, a comparative assessment of the control techniques is presented and discussed.

Keywords: Collocated PD, Fuzzy Logic Control, vibration control, flexible joint manipulator.

1. INTRODUCTION

Flexible-joint manipulators have received a thorough attention lately thanks to their light weight, high manoeuvrability, flexibility, high power efficiency, and large number of applications. However, controlling such systems still faces numerous challenges that need to be addressed before they can be used in abundance in everyday real-life applications. The control issue of the flexible joint is to design the controller so that link of robot can reach a desired position or track a prescribed trajectory precisely with minimum vibration to the link. In order to achieve these objectives, various methods using different technique have been proposed. Yim [1], Oh and Lee [2] proposed adaptive output-feedback controller based on a backstepping design. This technique is proposed to deal with parametric uncertainty in flexible joint. The relevant work also been done by Ghorbel et al. [3]. Lin and Yuan [4] and Spong et al. [5] introduced non linear control approach using namely feedback linearization technique and the integral manifold technique respectively. A robust control design was reported by Tomei [6] by using simple PD control and Yeon and Park [7] by applying robust H_∞ control. Among the proposed techniques, the conventional feedback control design handled by pole placement method and LQR method also have been widely used due to its simplicity implementation. Particularly in LQR method, the values of Q and R matrices are pre-specified to determine optimal feedback control gain via Riccati equation [8].

In recent years, tools of computational intelligence, such as artificial neural networks and fuzzy logic controllers, have been credited in various applications as powerful tools capable of providing robust controllers for mathematically ill-defined systems. This has led to the recent advances in the area of intelligent control [9,

10]. Various neural network models have been applied in the control of flexible joint manipulators, which have led to a satisfactory performance [11]. H. Chaoui et al. [12] used a sliding mode control approach that learns the system's dynamics through a feed-forward neural network. A time-delay neuro-fuzzy network was suggested in [13], where a linear observer was used to estimate the joint velocity signals and eliminated the need to measure them explicitly. Subudhi et al. [14] presented a hybrid architecture composed of a neural network to control the slow dynamic subsystem and an H_∞ to control the fast subsystem. A feedback linearization technique using a Takagi-Sugeno neuro-fuzzy engine was adopted in [15]. Lin and Chen [16] propose a combined rigid model-based computed torque and fuzzy control for flexible-joint manipulators.

This paper presents investigation into the development of hybrid collocated PD and Fuzzy Logic Control approach for trajectory tracking of tip angular position and vibration control of flexible joint manipulator respectively. Initially a collocated PD Control is developed for trajectory tracking of tip angular position. This is then extended to incorporate non-collocated Fuzzy Logic Control for vibration control of the manipulator. The performances of the composite control schemes are examined in terms of input tracking capability, level of vibration reduction and time response specifications. The rest of the paper is structured as follows: Section 2 provides a brief description of the single-link flexible joint manipulator system considered in this study. Section 3 describes the modelling of the system derived using Euler-Lagrange formulation. The composite collocated PD and Fuzzy Logic Control algorithms are described in Section 4. Simulation results and comparative assessment are presented in Section 5 and the paper is concluded in Section 6.

2. THE FLEXIBLE JOINT MANIPULATOR

The flexible joint manipulator system considered in this work is shown in Fig. 1, where θ , is the tip angular position and α is the deflection angle of the flexible joint. The base of the flexible joint manipulator which determines the tip angular position of the flexible link is driven by servomotor, while the flexible link will response based on base movement. The deflection of link will be determined by the flexibility of the spring as their intrinsic physical characteristics.

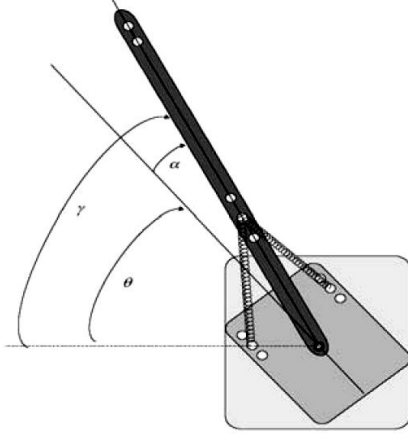

Fig. 1 Description of the flexible joint manipulator system.

3. MODELLING OF THE FLEXIBLE JOINT MANIPULATOR

This section provides a brief description on the modelling of the flexible joint manipulator system, as a basis of a simulation environment for development and assessment of the composite collocated PD and Fuzzy Logic control techniques. The Euler-Lagrange formulation is considered in characterizing the dynamic behaviour of the system.

The linear model of the uncontrolled system can be represented in a state-space form [17] as shown in equation (1), that is

$$\begin{aligned} \dot{x} &= Ax + Bu \\ y &= Cx \end{aligned} \quad (1)$$

with the vector $x = [\theta \quad \alpha \quad \dot{\theta} \quad \dot{\alpha}]^T$ and the matrices A , B and C are given by

$$A = \begin{bmatrix} 0 & 0 & 1 & 0 \\ 0 & 0 & 0 & 1 \\ 0 & \frac{K_{stiff}}{J_{eq}} & \frac{-\eta_m \eta_g K_t K_m K_g^2 + B_{eq} R_m}{J_{eq} R_m} & 0 \\ 0 & \frac{-K_{stiff}(J_{eq} + J_{arm})}{J_{eq} J_{arm}} & \frac{\eta_m \eta_g K_t K_m K_g^2 + B_{eq} R_m}{J_{eq} R_m} & 0 \end{bmatrix} \quad (2)$$

$$B = \begin{bmatrix} 0 & 0 & \frac{\eta_m \eta_g K_t K_g}{J_{eq} R_m} & \frac{-\eta_m \eta_g K_t K_g}{J_{eq} R_m} \end{bmatrix}, \quad C = [1 \quad 0 \quad 0 \quad 0]$$

In equation (1), the input u is the input voltage of the servomotor, V_m which determines the flexible joint manipulator base movement. In this study, the values of the parameters are defined in Table 1.

Table 1 System parameters

Symbol	Quantity	Value
R_m	Armature Resistance (Ohm)	2.6
K_m	Motor Back-EMF Constant (V.s/rad)	0.00767
K_t	Motor Torque Constant (N.m/A)	0.00767
J_{link}	Total Arm Inertia (kg.m ²)	0.0035
J_{eq}	Equivalent Inertia (kg.m ²)	0.0026
K_g	High gear ratio	14:5
K_{stiff}	Joint Stiffness	1.2485
B_{eq}	Equivalent Viscous Damping (N.m.s/rad)	0.004
η_g	Gearbox Efficiency	0.9
η_m	Motor Efficiency	0.69

4. CONTROL ALGORITHM

In this section, control schemes for rigid body motion control and vibration suppression of a flexible manipulator are proposed. Initially, a collocated PD controller is designed. Then a non-collocated fuzzy logic control is incorporated in the closed-loop system for control of vibration of the system.

4.1 Collocated PD Controller

A common strategy in the control of manipulator systems involves the utilization of PD feedback of collocated sensor signals. In this work, such a strategy is adopted at this stage. A block diagram of the PD controller is shown in Fig. 2, where K_p and K_v are proportional and derivative gains, respectively, θ and $\dot{\theta}$ represent tip angular position and its velocity, respectively, $r(t)$ is the reference tip angular position and A_c is the gain of the motor amplifier. Here the motor/amplifier gain set is considered as a linear gain. To design the PD controller, a linear state-space model of the flexible joint manipulator was obtained by linearising the equations of motion of the system.

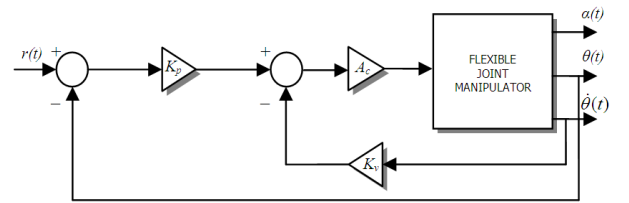

Fig. 2 Collocated PD control structure.

The control signal $u(s)$ in Fig. 2 can be written as

$$u(s) = A_c [K_p \{R_f(s) - \theta(s)\} - K_v s \theta(s)] \quad (3)$$

where s is the Laplace variable. The closed-loop transfer function is, therefore, obtained as

$$\frac{\theta(s)}{R_f(s)} = \frac{K_p H(s) A_c}{1 + A_c K_v (s + K_p / K_v) H(s)} \quad (4)$$

where $H(s)$ is the open-loop transfer function from the input torque to tip angular position, given by

$$H(s) = C(sI - A)^{-1} B \quad (5)$$

where A , B , and C are the characteristic matrix, input matrix and output matrix of the system, respectively, and I is the identity matrix. The closed-loop poles of the system are, thus, given by the closed-loop characteristics equation as

$$1 + A_c K_v (s + K_p / K_v) H(s) \quad (6)$$

where $Z = K_p / K_v$ represents the compensator zero which determines the control performance and characterizes the shape of root locus of the closed-loop system. In this study, the root locus approach is utilized to design the PD controller.

4.2 Collocated PD with non-collocated Fuzzy Logic

A combination of collocated PD and non-collocated fuzzy logic control scheme for control of tip angular position and vibration suppression of the system respectively is presented in this section. The use of a non-collocated control system, where the deflection angle of the flexible joint manipulator is controlled by measuring its angle, can be applied to improve the overall performance, as more reliable output measurement is obtained. The control structure comprises two feedback loops: (1) The hub angle as input to collocated PD for tip angular position control. (2) The deflection angle as input to a separate non-collocated control law for vibration control. These two loops are then summed together to give a torque input to the system. A block diagram of the composite PD and fuzzy logic control scheme is shown in Fig. 3.

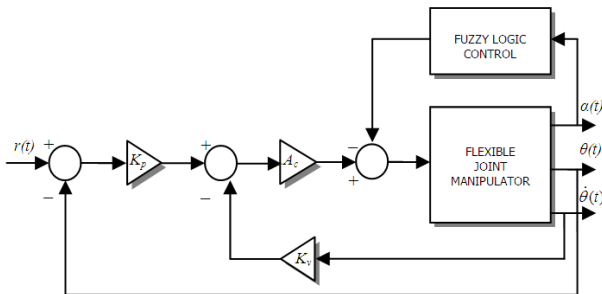

Fig. 3 Collocated PD with non-collocated Fuzzy Logic control structure.

For tip angular position control, the collocated PD strategy developed in the previous section is adopted whereas for the vibration control loop, the deflection

angle feedback through a non-collocated fuzzy logic control scheme is utilised. In designing the non-collocated fuzzy logic control, a basic triangle and trapezoidal forms are chosen for input and output membership functions. Fig. 4 shows the membership functions of the fuzzy logic controller for vibration control. It consists of Negative Big (NB), Negative Small (NS), Zero (Z), Positive Small (PS) and Positive Big (PB) as shown in the diagram. The universes of discourses of deflection angle, deflection angle rate and input voltage are from 9.2 to -9.2 rad, 7.8×10^{-5} to -7.8×10^{-5} rad/s and -350 to 350 V respectively.

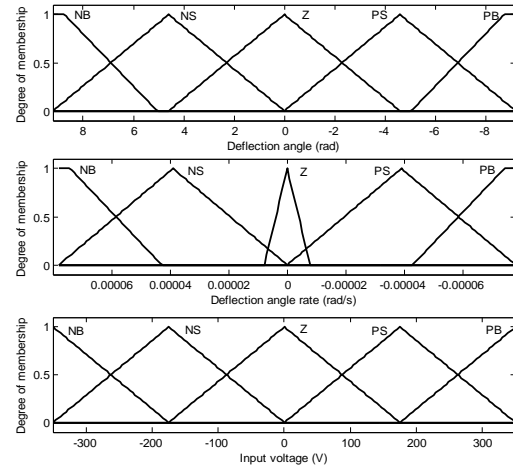

Fig. 4 Membership functions of inputs and output signals.

Table 2 lists the generated linguistic rules for vibration control. The rules are designed based on the condition of the deflection angle and the deflection angle rate as illustrated in Fig. 5. Consider the joint of the manipulator rotates to anti-clockwise direction and the link deflects on clockwise direction. As illustrated in Fig. 5(a), at this condition intuitively the torque should be applied to clockwise direction in order to compensate the deflection. In this case the relation between input voltage and torque per inertia is shown in equation (7),

$$\tau = \frac{V_m \eta_m \eta_g K_t K_g}{R_m} \quad (7)$$

Table 2 Fuzzy rules for vibration control

Deflection angle rate		$\dot{\alpha}$				
		PB	PS	Z	NS	NB
Deflection angle	PB	PB	PB	PB	NB	NB
	PS	PB	PS	PS	NS	NB
	Z	PB	PS	Z	NS	NB
	NS	PB	PS	NS	NS	NB
	NB	PB	PB	NB	NB	NB

Meanwhile, if the joint rotates to clockwise direction as shown in Fig. 5(b) and the link deflects to anti-clockwise direction, the torque should be imposed to anti-clockwise direction to suppress the deflection motion. In the case there is no deflection, no torque should be applied. Furthermore, the proposed fuzzy logic control adopts well-known Mamdani min-max inference and centre of area (COA) methods.

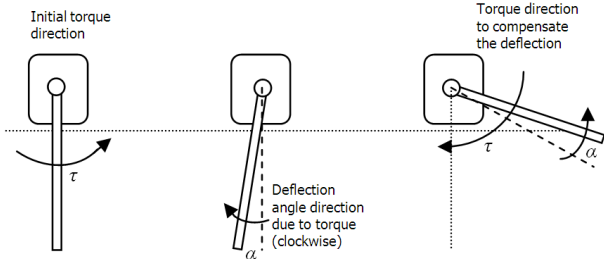

(a) Direction of torque to reduce deflection angle when link moves anti-clockwise

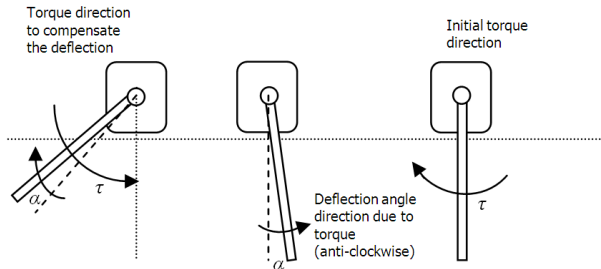

(b) Direction of torque to reduce deflection angle when link moves clockwise

Fig. 5 Rules generation based on the motion condition.

5. IMPLEMENTATION AND RESULTS

In this section, the proposed control schemes are implemented and tested within the simulation environment of the flexible joint manipulator and the corresponding results are presented. The manipulator is required to follow a trajectory of 50° . System responses namely the tip angular position and deflection angle are observed. To investigate the vibration of the system in the frequency domain, power spectral density (PSD) of the deflection angle response is obtained. The performances of the control schemes are assessed in terms of vibration suppression, trajectory tracking and time response specifications. Finally, a comparative assessment of the performance of the control schemes is presented and discussed.

Figs. 6-8 show the responses of the flexible joint manipulator to the reference input trajectory using collocated PD control in time-domain and frequency domain (PSD). These results were considered as the system response under rigid body motion control and will be used to evaluate the performance of the non-collocated fuzzy logic control. The steady-state tip angular trajectory of 50° for the flexible joint manipulator was achieved within the rise and settling times and overshoot of 0.446 s, 0.853 s and 0.78 % respectively. It is noted that the manipulator reaches the

required position within 1 s, with little overshoot. However, a noticeable amount of vibration occurs during movement of the manipulator. It is noted from the deflection angle response that the vibration of the system settles within 5 s with a maximum residual of $\pm 10^\circ$. Moreover, from the PSD of the deflection angle response the vibrations at the flexible joint are dominated by the first vibration mode, which are obtained as 2.94 Hz with magnitude of 38.90 dB.

The tip angular position, deflection angle and power spectral density responses of the flexible joint manipulator with composite PD and Fuzzy Logic control are shown in Figs. 6-8 respectively. It is noted that the proposed control schemes are capable of reducing the system vibration while maintaining the trajectory tracking performance of the manipulator. Similar tip angular position, deflection angle and power spectral density of deflection angle responses were observed as compared to the PD controller. With composite PD and Fuzzy Logic control, the steady-state tip angular trajectory of 50° for the flexible joint manipulator was achieved within the rise and settling times and overshoot of 0.275 s, 0.501 s and 3.24 % respectively. The manipulator reaches the required position within 0.3 s, with higher overshoot as compared to PD controller. However, the settling time of composite PD and Fuzzy Logic control is much faster as compared to the case of PD control. It is noted that a significant amount of vibration reduction was demonstrated at the tip angle of the manipulator with composite PD and Fuzzy Logic control. This can be clearly seen from the deflection angle response that the vibration of the system settles within 1 s with a maximum residual of $\pm 6^\circ$. Moreover, from the PSD of the deflection angle response, the magnitudes of vibrations were reduced to -9.86 dB for the first mode of vibration.

Table 3 summarises the magnitude of vibration of deflection angle and specifications of tip angular position response for both control schemes. It is noted that high performance in the reduction of vibration of the system is achieved using composite PD and Fuzzy Logic control. This is observed and compared to the collocated PD at the first mode of vibration. For comparative assessment, the level of vibration reduction of the deflection angle was obtained as 48.76 dB at the first mode of vibration. Moreover, almost twofold improvement in the magnitude of deflection angle reduction was observed with composite PD and Fuzzy Logic control as compared to the collocated PD. In addition, as demonstrated in the tip angular trajectory response, a slightly faster response with higher overshoot are obtained using composite PD and Fuzzy Logic control as compared to the collocated PD control. Comparisons of the specifications of the tip angular trajectory responses are summarised in Table 3. Besides, as demonstrated in the tip angular trajectory response with composite PD and Fuzzy Logic control, the minimum phase behaviour of the manipulator is unaffected. Nevertheless, the implementation of

composite PD and Fuzzy Logic control required a large amount of design effort in order to determine the best range of membership functions parameters. Note that a properly tuned membership functions range for input and output signal could produce better results.

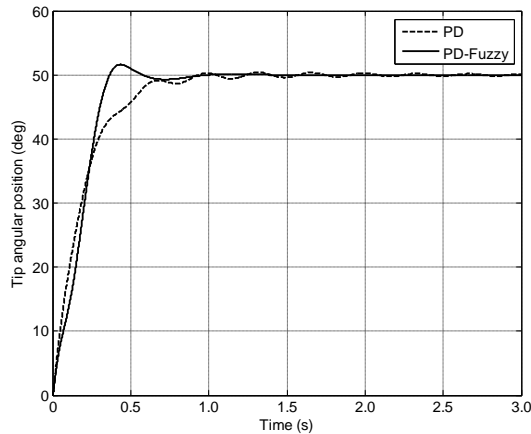

Fig. 6 Tip angular position response.

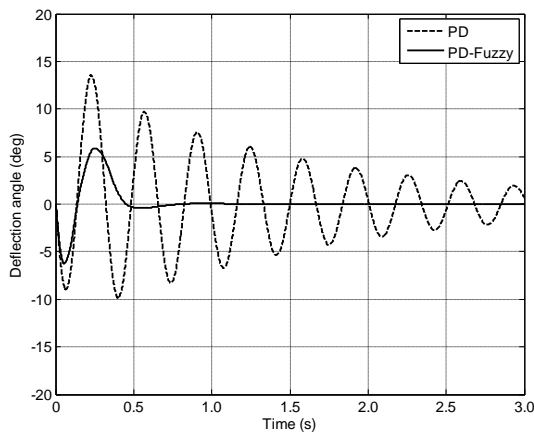

Fig. 7 Deflection angle response.

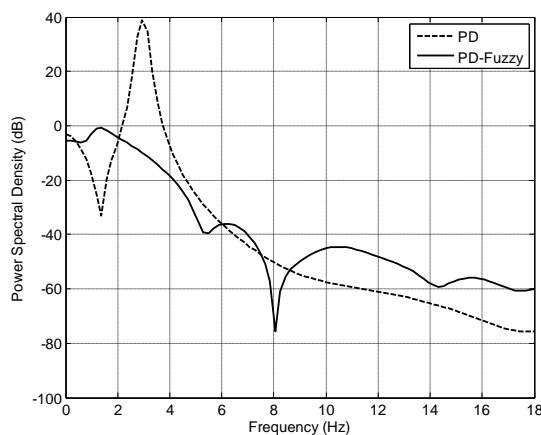

Fig. 8 PSD of deflection angle.

Table 3 Magnitude of vibration and specifications of tip angular position

Controller		PD	PD-Fuzzy
Magnitude of vibration (dB)	Mode 1	38.90	-9.86
	Mode 2	38.90	-9.86
Specifications of tip angular position response	Settling time (s)	0.853	0.501
	Rise time (s)	0.446	0.275
	Overshoot (%)	0.78	3.24

6. CONCLUSIONS

The development of composite PD and fuzzy logic control techniques for trajectory tracking and vibration suppression of a flexible joint manipulator has been presented. The control schemes have been developed based on collocated PD and collocated PD with non-collocated fuzzy logic control. The proposed control schemes have been implemented and tested within simulation environment of a single-link flexible joint manipulator. The performances of the control schemes have been evaluated in terms of input tracking capability and vibration suppression at the resonance mode of the manipulator. Acceptable performance in input tracking and vibration control has been achieved with proposed control strategies. A significant amount of vibration reduction at the joint of the manipulator was demonstrated with composite PD and Fuzzy Logic control. Moreover, in term of speed of responses, composite control scheme results in a faster settling time response with high overshoot as compared to collocated PD. The work thus developed and reported in this paper forms the basis of design and development of hybrid control schemes for input tracking and vibration suppression of multi-link flexible manipulator systems and can be extended to and adopted in practical applications.

ACKNOWLEDGEMENT

This work was supported by Faculty of Electrical & Electronics Engineering, Universiti Malaysia Pahang, especially Control & Instrumentation (COINS) Research Group.

REFERENCES

- [1] W. Yim, "Adaptive Control of a Flexible Joint Manipulator", *Proc. 2001 IEEE, International Robotics & Automation*, Seoul, Korea, pp. 3441–3446, 2001.
- [2] J. H. Oh and J. S. Lee, "Control of Flexible Joint Robot System by Backstepping Design Approach", *Proc. of IEEE International Conference on Robotics & Automation*, pp. 3435–3440, 1997.
- [3] F. Ghorbel, J.Y. Hung and M.W. Spong, "Adaptive Control of Flexible Joint Manipulators", *Control Systems Magazine*, Vol. 9, pp. 9–13, 1989.
- [4] L.C. Lin and K. Yuan, "Control of Flexible Joint Robots via External Linearization Approach",

- Journal of Robotic Systems*, Vol. 1 (1), pp. 1-22, 2007.
- [5] M. W. Spong, K. Khorasani and P. V. Kokotovic, "An Integral Manifold Approach to the Feedback Control of Flexible Joint Robots", *IEEE Journal of Robotics and Automation*, Vol. RA-3, No.4, pp. 291-300, 1987.
- [6] P. Tomei, "A Simple PD Controller for Robots with Elastic Joints", *IEEE Trans. on Automatic Control*, Vol. 36, No. 10, pp. 1208-1213, 1991.
- [7] J. S. Yeon and J. H. Park, "Practical Robust Control for Flexible Joint Robot Manipulators", *Proc. 2008 IEEE International Conference on Robotic and Automation*, Pasadena, CA, USA, pp. 3377-3382, 2008.
- [8] M.A. Ahmad, "Vibration and Input Tracking Control of Flexible Manipulator using LQR with Non-collocated PID controller", *Proc. of 2nd UKSIM European Symposium on Computer Modelling and Simulation*, UK, pp. 40-45, 2008.
- [9] M.A. Ahmad, R.M.T. Raja Ismail, M.S. Ramli, M.A. Zawawi, N. Hambali and N.M. Abd Ghani, "Vibration Control of Flexible Joint Manipulator using Input Shaping with PD-type Fuzzy Logic Control", *Proceedings of IEEE International Symposium on Industrial Electronics*, Seoul, pp. 1184-1189, 2009.
- [10] M.A. Ahmad, A.N.K. Nasir, N. Hambali and H. Ishak, "Vibration and Input Tracking Control of Flexible Manipulator using Hybrid Fuzzy Logic Controller", *Proceedings of the IEEE International Conference of Mechatronics and Automation*, Kagawa, pp. 593-598, 2008.
- [11] H. Chaoui, W. Gueaieb, M. Yagoub, P. Sicard, "Hybrid neural fuzzy sliding mode control of flexible-joint manipulators with unknown dynamics", *Proceedings of the 32nd Annual Conference of the IEEE Industrial Electronics Society (IECON-2006)*, pp. 4082-4087, 2006.
- [12] H. Chaoui, P. Sicard, A. Lakhsasi, "Reference model supervisory loop for neural network based adaptive control of a flexible joint with hard nonlinearities", *IEEE Canadian Conference on Electrical and Computer Engineering*, vol. 4, pp. 2029-2034, 2004.
- [13] D. Hui, S. Fuchun, S. Zengqi, "Observer-based adaptive controller design of flexible manipulators using time-delay neuro-fuzzy networks", *J. Intell. Robot. Syst.: Theory and Applications*, 34(4), pp. 453-466, 2002.
- [14] B. Subudhi, A. Morris, "Singular perturbation based neuro-h infinity control scheme for a manipulator with flexible links and joints", *Robotica* 24(2), pp. 151-161, 2006.
- [15] C.W. Park, "Robust stable fuzzy control via fuzzy modeling and feedback linearization with its applications to controlling uncertain single-link flexible joint manipulators", *J. Intell. Robot. Syst.: Theory and Applications*, 39(2), pp. 131-147, 2004.
- [16] L. C. Lin and C. C. Chen, "Rigid model-based fuzzy control of flexible-joint manipulators", *J. of Intelligent and Robotic Systems*, 13, pp. 107-126, 1995.
- [17] Quanser Student Handout, Rotary Flexible Joint Module. <http://www.quanser.com>.