

PAPER • OPEN ACCESS

Thermodynamic performance prediction of rhombic-drive beta-configuration Stirling engine

To cite this article: Z M Farid *et al* 2019 *IOP Conf. Ser.: Mater. Sci. Eng.* **469** 012048

View the [article online](#) for updates and enhancements.



IOP | ebooks™

Bringing you innovative digital publishing with leading voices to create your essential collection of books in STEM research.

Start exploring the collection - download the first chapter of every title for free.

Thermodynamic performance prediction of rhombic-drive beta-configuration Stirling engine

Z M Farid¹, R M Faiz¹, A B Rosli^{1*} and K Kumaran¹

¹Faculty of Mechanical Engineering, Universiti Malaysia Pahang, 26600 Pekan, Pahang, Malaysia

*Corresponding author: rosli@ump.edu.my

Abstract. A single-cylinder rhombic drive beta-configuration Stirling engine, heated and cooled at designated temperature, and fuelled with a fixed amount of Helium gas is used to predict and analyse the thermodynamic cycle performance. A general zero-dimensional numerical model is adapted throughout the prediction of Stirling engine performance. The numerical model is determined based on overall geometrical parameters, working fluid properties, swept and unswept volume. Schmidt and ideal adiabatic analysis based on methodology presented by Berchowitz and Urieli are carried out to predict the cycle pressure, volumetric displacement, work and energy produced during the expansion and compression processes in the cylinder. Based on the designated working condition, the engine is predicted to generate 500 W of power at engine speed of 300 rpm. The indicated thermal efficiency is found to be 66% based on 90° phase angle setting, 4.5 bar of Helium cylinder mean pressure, 893 K of expansion space temperature and 303 K of cooler space temperature.

1. Introduction

The progressive development and improvement of power generator technology became significant efforts for providing healthier environment to the population, as well as minimizing the worsening environmental problems. In the energy conversion system, the combustion of conventional fossil fuel-based energy conversion devices induced adverse impact to the environment and population [1]. The emissions produced by the combustion of fossil fuel-based energy conversion device increased the global emission level [2]. Fossil-based energy conversion devices are commonly constructed based on internal combustion reciprocating engines principle. The combustion propulsion power is transmitted to the reciprocating components and then to the rotational components of the engine. The rotational power produced is used to drive any kind of devices that requires mechanical energy for energy conversion process. The implementation of internal combustion engines as energy conversion devices indicate significant higher power output, however it depends on the engine design [3].

In contrary, another type of energy conversion devices is an external combustion engine, which are differ from the internal combustion engine. The external combustion engines do not require any internal combustions propulsion from fuel, which provide significant advantage of producing low emissions level [4]. The external combustion engines only utilize continuous external heat sources supply from combustion of any combustible materials to generate mechanical energy. Stirling engines are categorized as external combustion engines that utilize external heat sources to produce mechanical energy. The Stirling engines provide significant advantages whereby it can be easily designed and constructed [5]. Besides, higher thermal efficiency and ability to use any kind of heat sources constitute



the Stirling engines as an alternative method of minimizing the environmental problems for green energy production [6].

For the present work, the thermodynamic cycle prediction is carried out based on the numerical model of rhombic drive beta-configuration Stirling engine. The prediction of reciprocating and volumetric displacement, working fluid cycle pressure, cyclic energy flow, and engine performance at different phase angle setting, heat source temperature, and working fluid charge pressure and engine speed are carried out and discussed.

2. Methodology

The thermodynamic prediction of rhombic drive beta-configuration Stirling engine is carried out based on the methodology developed by Berchowitz and Urieli. Based on the methodology presented, a simplified Stirling Engine Analysis (SEA) MATLAB is developed, as shown in Figure 1. The prediction is carried out based on an ideal adiabatic model from Schmidt theory, which utilizes five volumes approaches [6]. For the prediction, the Schmidt analysis is performed to initialize the ideal adiabatic condition. In this work, similar methodology approach is applied to the working space of the engine. In this model, it is assumed that there are no internal heat exchanger surfaces, but only depends on the displacer and power piston cylinder walls for heat addition and rejection process. The schematic diagram for volume definition is shown in Figure 2. The model is configured to have three main zones; heating, regenerating and cooling zone. In the heating zone, three working volumes are determined; expansion space clearance volume, heater volume, and expansion space swept volume. In the regenerating zone, the displacer piston-cylinder gap is defined as regenerator volume. Meanwhile, the cooling zone has compression space clearance volume, cooler volume and compression space swept volume. Figure 3 shows a schematic diagram of rhombic drive beta-configuration Stirling engine based on single-cylinder arrangement. The working space is divided into three sections; expansion space, regenerating space and compression space. Based on rhombic drive features with compensation between engine stroke, phase angle setting, components tolerance and failure factors, the overall engine geometrical parameters are listed in Table 1.

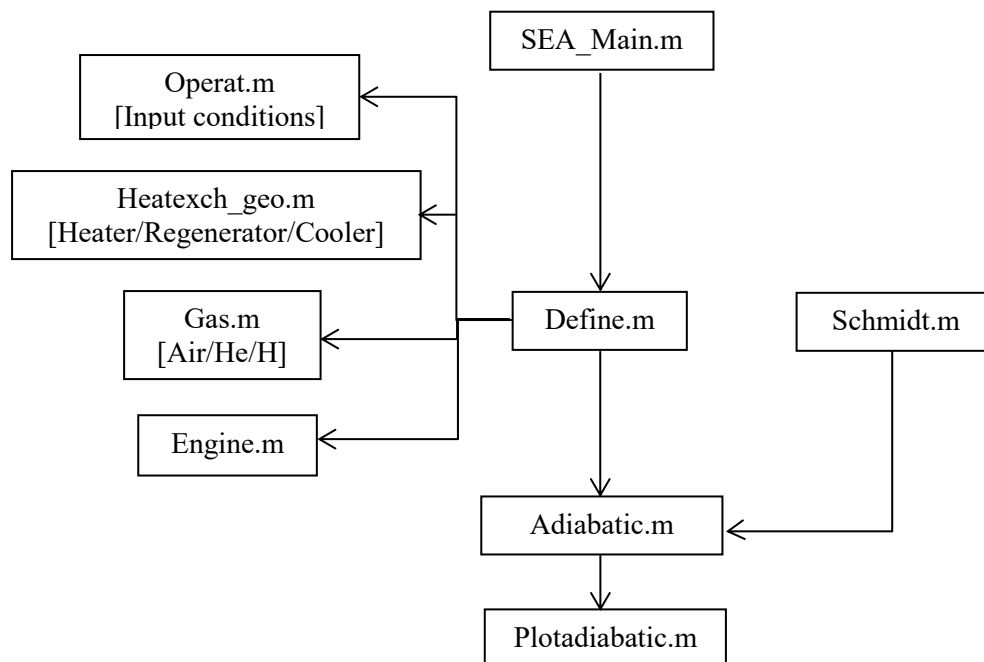


Figure 1. Simplified SEA MATLAB program layout.

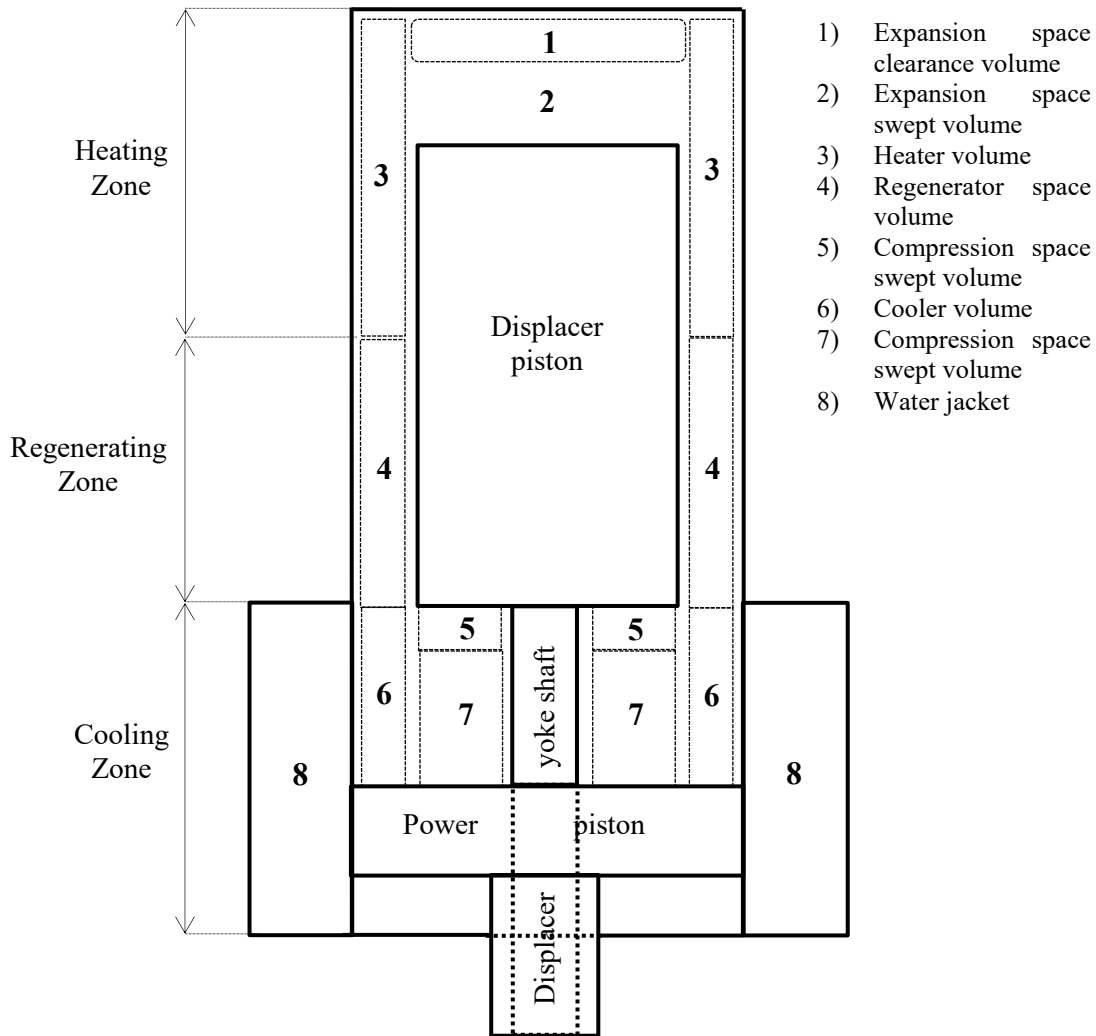


Figure 2. Schematic diagram for volume definition.

The expansion space varies over a cycle with the movement of the displacer piston, while the compression space varies based on the movement of both displacer and power piston. For rhombic drive mechanism, two units of spur gears with equal radius are meshed together and rotate in opposite directions. Four units of identical connecting rods, displacer and power piston yoke, are used to provide reciprocating motion without side thrust for both pistons. The whole arrangement is symmetry with respect to the vertical centre line. The reciprocating displacement of both displacer (Y_d) and power pistons (Y_p) can be calculated by using following relations [7]:

$$Y_d = L_{dt} + r \sin \theta - [L^2 - (R_g - d_d - r \cos \theta)^2]^{1/2} \quad (1)$$

$$Y_p = L_{pt} + r \sin \theta + [L^2 - (R_g - d_p - r \cos \theta)^2]^{1/2} \quad (2)$$

where the crank angle, θ is rotating in a clockwise direction. Then, the reciprocating volumetric displacement of expansion space (V_{swe}) and compression space (V_{swc}) can be determined based on Y_d and Y_p . Considering the cross-sectional area of the displacer piston, the swept volume of expansion space (V_{swe}) and compression space (V_{swc}) are expressed as:

$$V_{swe} = \pi (b_d^2 / 4) (L_t - c_{dc} - Y_d) \quad (3)$$

$$V_{swc} = \pi (b_d^2 / 4) (Y_p + (Y_d - l_d)) \quad (4)$$

The volume of the cooler in the cooling zone is not constant and depends on the power pistons position. The cooler volume is assumed to be constant based on the volume definitions and equation sets for alpha-configuration Stirling engine. Meanwhile, the heating and regenerating zone of this model are assumed to be similar as alpha-configuration, since the volume of heater and regenerator are constant for any value of crank angle position. The heater volume (V_h), regenerator volume (V_r) and cooler volume (V_k) are expressed as:

$$V_h = (\pi / 4) [(b_{dc} - b_d)^2] l_H \quad (5)$$

$$V_r = (\pi / 4) [(b_{dc} - b_d)^2] l_R \quad (6)$$

$$V_k = (\pi / 4) [(b_p - b_d)^2] S \quad (7)$$

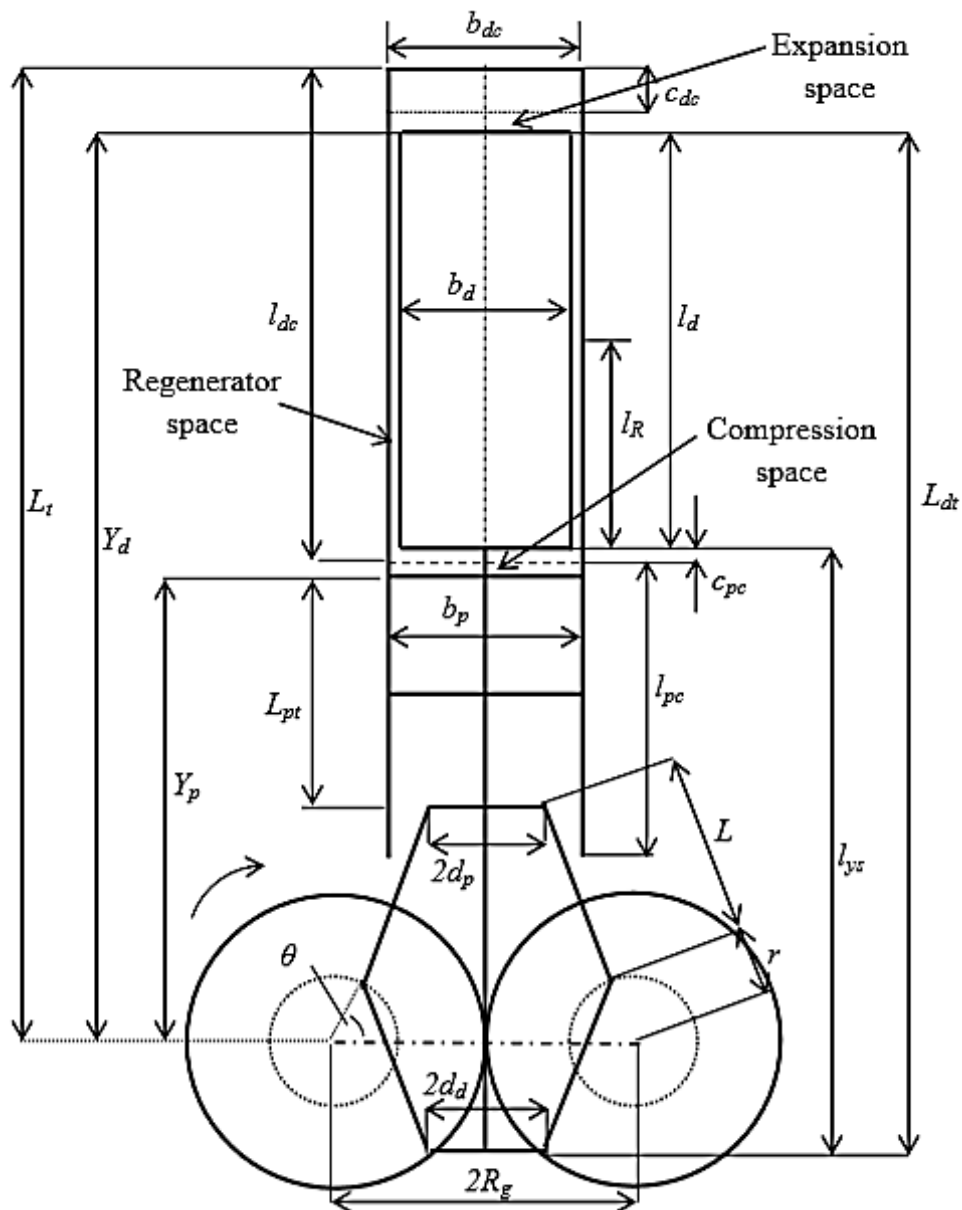


Figure 3. Schematic diagram of rhombic drive beta-configuration Stirling engine.

Table 1. Overall components geometrical parameters.

Components	Label	Dimension (mm)
Total length	L_t	416
Displacer cylinder length	l_{dc}	200
Displacer cylinder bore	b_{dc}	84
Displacer top clearance	c_{dc}	3
Displacer piston length	l_d	182
Displacer piston bore	b_d	81
Regenerator length	l_R	152
Power piston top clearance	c_{pc}	3
Power piston length	L_{pt}	50
Power piston cylinder length	l_{pc}	144
Power piston cylinder bore	b_p	80
Displacer piston yoke shaft	l_{ys}	262
Power piston yoke	$2d_p$	50
Displacer piston yoke	$2d_d$	50
Connecting rod length	$L_p = L_d = L$	80.5
Crank offset radius	r	38
Spur gear pitch diameter (PCD)	$2R_g$	130

3. Results and discussions

Figure 4 shows the volumetric displacement of the numerical model equipped with rhombic drive mechanism. The displacer piston position is assumed to be at 90° crank angle. As the displacer moves downward, the volume in the expansion space increased while the volume in the compression space decreased to minimum since there is a clearance between displacer bottom surface and power piston upper surface. The interaction between working space volume and pressure is also shown in Figure 4. It is assumed that the engine is pressurized with Helium gas at a constant pressure of 4.5 bar. The pressure varies from minimum of 1.8 bar to 11.4 bar during the engine cycle. Since there is a reduction in engines total volume, the pressure rises to a maximum based on the movement of driving mechanism.

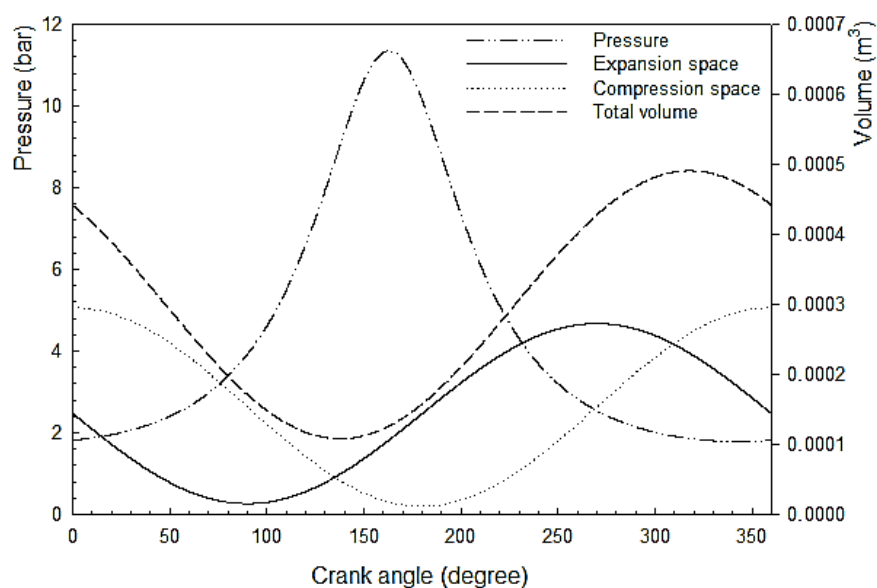
**Figure 4.** Volumetric displacement and working fluid cycle pressure.

Figure 5 shows the P-V diagram of the Stirling engine based on the geometrical and operating parameters. Larger area of total volume indicates better engine performance, since the engine does larger amount of work. However, the selection of working fluid properties, heat exchanger design and engines geometrical parameters can attribute to the engine performance [8]. The variation of cyclic energy flow in the expansion and compression space is shown in Figure 6. The net amount of the heat energy remaining in the expansion space is transferred to the compression space while the heat is being rejected to the cooler. High thermal energy is absorbed by the expansion space and significant amount of heat is rejected, resulting the increment in total energy output.

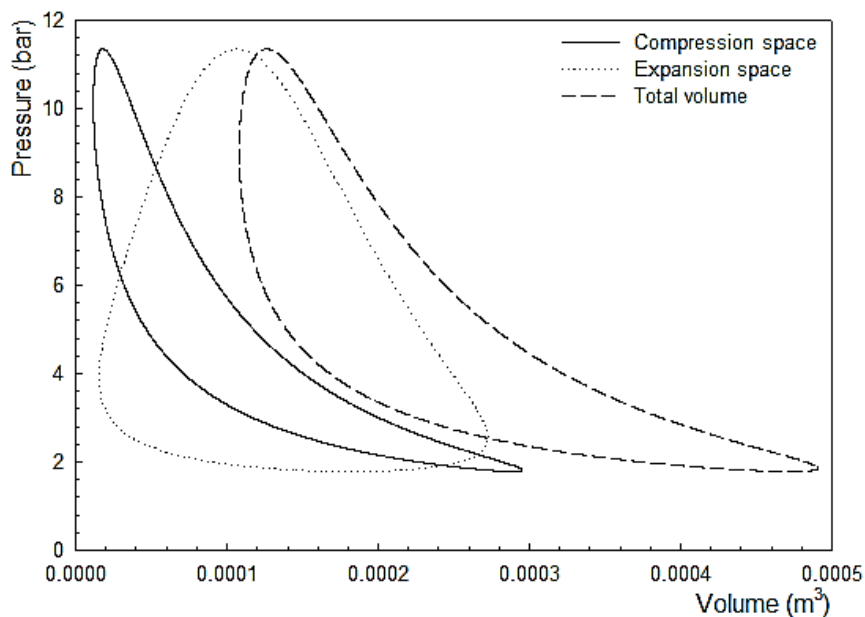


Figure 5. P-V diagram.

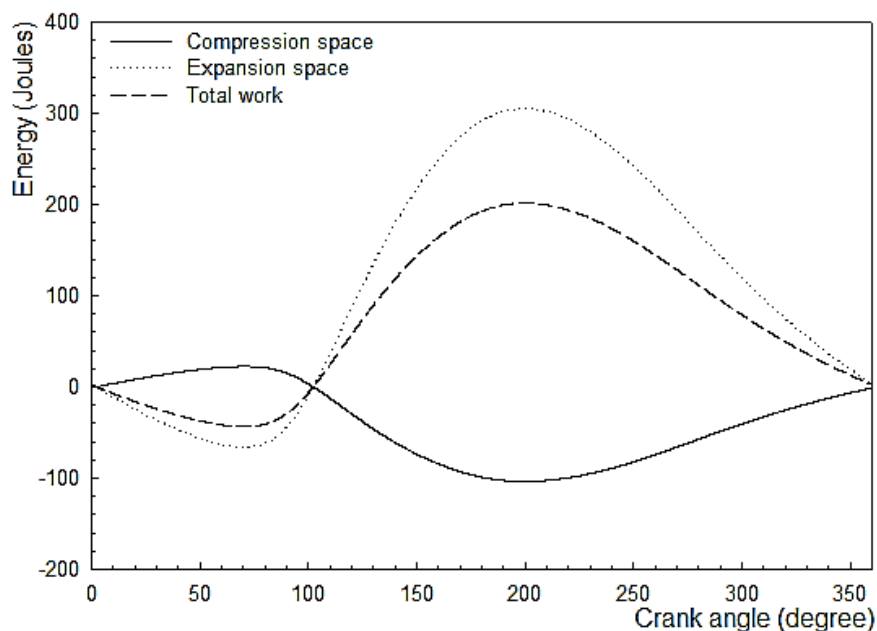


Figure 6. Cyclic energy flow.

The variation of engine power output at different phase angle setting is shown in Figure 7. The figure shows that the engine power output varies with different displacer-power piston phase angle setting, however does not affect the thermal efficiency. The thermal efficiency is calculated to be 66% based on the heat source temperature of 893 K and cooler temperature of 303 K, as listed in Table 2. Based on the working fluid charge pressure, heat source and cooler temperatures, the engine is predicted to produce approximately 500 Watts at 300 rpm. Based on literature, a 90° phase angle setting indicates optimum setting since there is a maximum power output can be produced [9]. With a larger phase angle setting, the working fluid could have sufficient heating and cooling period during expansion and compression processes. As a result, more energy is absorbed from the heat source and rejected to the cooler [5,6]. Meanwhile, the increases in engines power output and thermal efficiency based on different heat source temperatures is shown in Figure 8. The result shows that the increases in heat source temperature enhanced the engines power, as well as the thermal efficiency. It is clearly shows that the enhancement of engines power and efficiency due to heat source temperature are limitless, therefore it will require usage of advanced material that can resist to high-temperature heat source [6].

Table 2. Performance of prediction from numerical model.

Parameters	Result
Maximum pressure in cylinder (bar)	11.35
Minimum pressure in cylinder (bar)	1.78
Expansion swept volume (m ³)	2.7250x10 ⁻⁴
Compression swept volume (m ³)	2.9520x10 ⁻⁴
Heater volume (m ³)	3.3929x10 ⁻⁷
Regenerator volume (m ³)	1.0744x10 ⁻⁶
Cooler volume (m ³)	6.9814x10 ⁻⁷
Power (Watts)	496
Thermal efficiency (%)	66
Heat source temperature (K)	893
Cooler temperature (K)	303

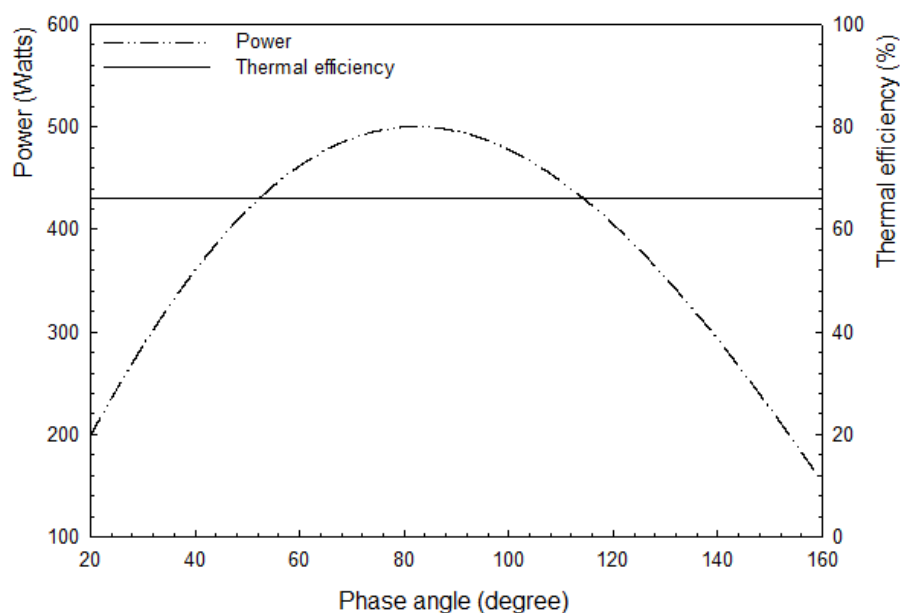


Figure 7. Variation of power at different phase angle.

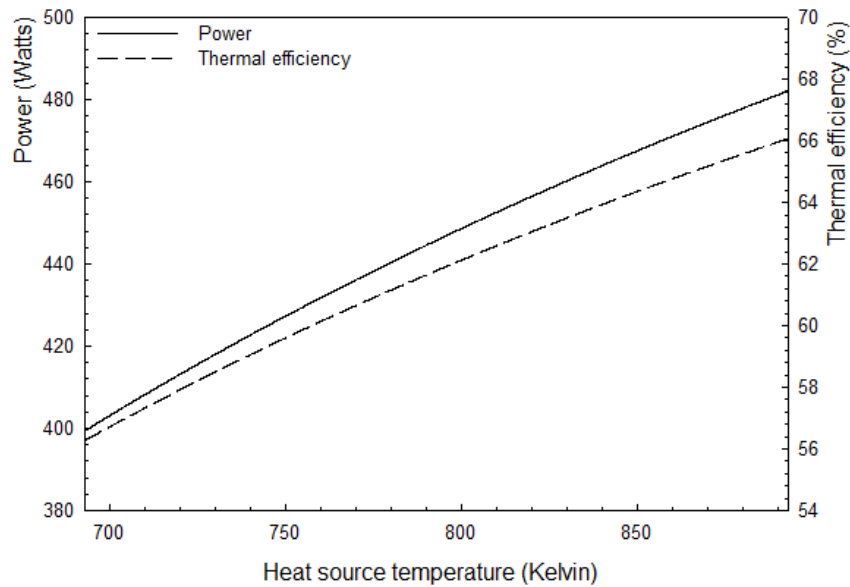


Figure 8. Effect of power and efficiency at different heat source temperature.

Figure 9 shows the effect of engines power at different working fluid charge pressure. The engines power is significantly increased as the charge pressure increased. As the charge pressure increased, the increment in working fluid mass caused better heat transfer and higher thermal energy absorption in the expansion space and higher heat rejection to the cooler in the compression space. As a result, pressurization in the cylinder indicates a significant method in enhancing the engine performance [10]. Higher power output can be achieved since less energy required to overcome the working fluid flow friction and frictional forces of contact surfaces between moving components. Figure 10 shows the engines power based on different engine speed. Higher indicated power can be achieved with greater engine speed. Therefore, proper design of moving components and usage of lightweight materials become an important criterion for achieving higher engine speed while minimizing the inertial forces of moving components [11].

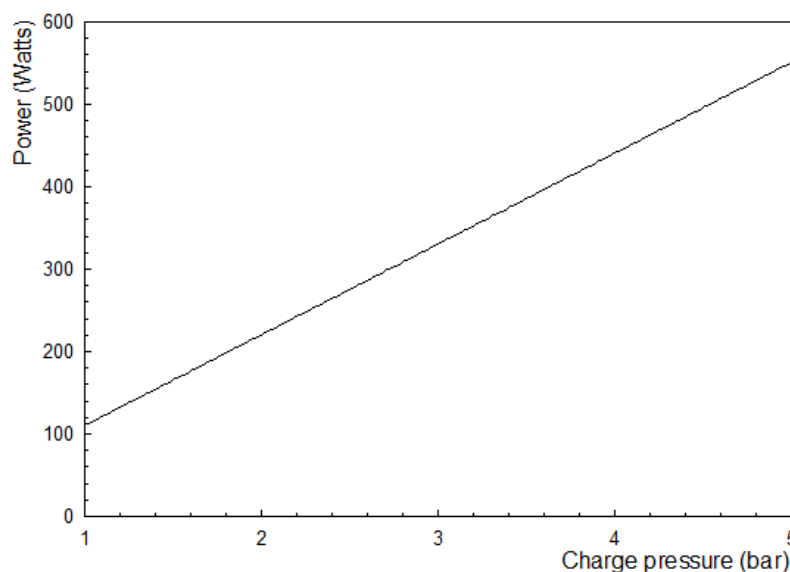


Figure 9. Effect of engines power at different working fluid charge pressure.

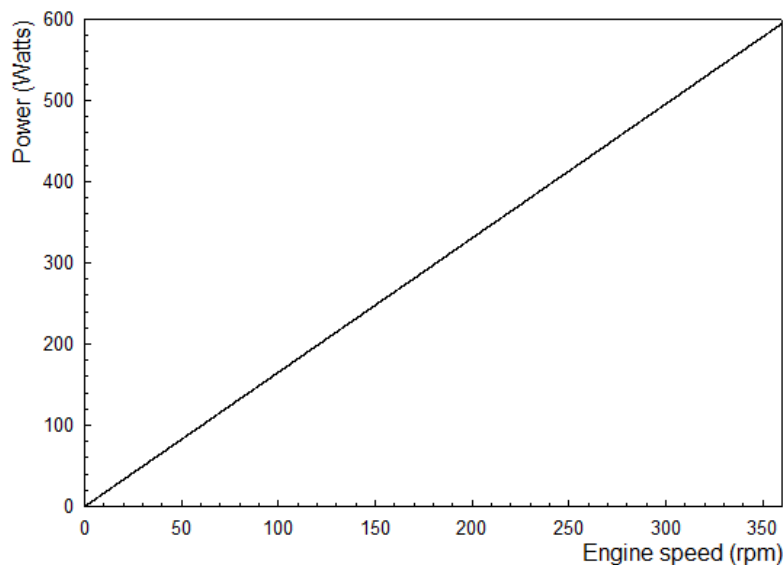


Figure 10. Effect of engines power at different engine speed.

4. Conclusion

The prediction of rhombic drive beta-configuration Stirling engine performance is carried out through a numerical model. The prediction of engines volumetric displacement, cycle pressure, cyclic energy flow and effect of engines performance at different phase angle setting, heat source temperature, charge pressure and engine speed within the numerical model are presented and discussed. Based on the variation of engine's power curve, the phase angle setting plays an important role in determining the maximum power output. It indicates the optimum heat addition during heating and heat rejection during cooling period as the engine runs at certain expansion space and cooling space temperatures. However, a 90° setting is not the essential phase angle setting for producing higher power output. Phase angle control is one of the method in achieving desired power output, depending on the engine designs and applications. From the simulation results, the engine is predicted generating approximately 500 Watts of power at indicated speed of 300 rpm. The indicated thermal efficiency is calculated to be 66% with a heat source temperature of 893 K and cooler temperature of 303 K. However, further experimental works and comparative study with other previous work will be carried out in order to validate the numerical results.

References

- [1] Chen W L, Wong K L and Po L W 2012 *Energy Conv. and Manage.* 62 84-92
- [2] Sripakagorn A and Srikam C 2011 *Renewable Energy* 36 1728-1733
- [3] Roberts A Brooks R and Shipway P 2014 *Energy Conv. and Manage* 82 327-350
- [4] Tlili I Timoumi Y and Nasrallah S B 2008 *Renewable Energy* 33 1911-1921
- [5] Kongtragool B and Wongwises S 2003 *Renew. and Sust. Energy Rev.* 7 131-154
- [6] Thombare D G and Verma S K 2008 *Renew. and Sust. Energy Rev.* 12 1-38
- [7] Cheng C H and Yu Y J 2010 *Renewable Energy* 35 2590-2601
- [8] Snyman H 2007 Second order analyses methods for Stirling engine design
- [9] Sorea N and Cernomazu D 2009 3rd International Symposium on Electrical Eng. and Energy Conver.
- [10] Cinar C, Yucesu S, Topgul T and Okur M 2005 *Applied Energy* 81 351-357
- [11] Ming G L 2012 Development of Dish-Stirling concentrating solar thermal-electric energy conversion system