

Adaptive Modulation and Superposition Coding for MIMO Data Transmission Using Unequal Error Protection and Ordered Successive Interference Cancellation Techniques

Wasan Kadhim Saad¹, Waheb A. Jabbar², and Bashar J. Hamza¹

¹Al-Furat Al-Awsat Technical University, Engineering Technical College-Najaf, 31001 Najaf, Iraq

²Faculty of Engineering Technology, Universiti Malaysia Pahang (UMP), Lebuhraya Tun Razak, 26300, Gambang, Kuantan, Pahang, Malaysia

Email: wasan.saad@ieee.org, waheb@ieee.org, mrym_bashar@yahoo.com

Abstract—This paper proposes and discusses an efficient multiple input multiple output (MIMO) system for adaptive modulation coding (AMC) based on unequal error protection (UEP) and superposition coding (SPC) by exploiting the features of sub channel partitioning. Using AMC, an appropriate order of modulation and code rate to suit the channel state information (CSI) can be selected. The realization of UEP is achieved through adaptive allocation and transmission of high and low-priority data signals over high and low quality sub channels respectively. A multistage decoding (MSD) receiver with the ordered successive interference cancellation (OSIC) technique is employed in the receiver by using two linear receiver signal combiner (RSC) techniques: zero-forcing (ZF) and minimum mean square error (MMSE). The data priority can be distinguished by the signal-to-noise ratio (SNR) and can be categorized as mode-B and mode-G. The simulation results show that the SNR performance enhancement for the UEP-MIMO scheme is approximately 9.4 dB compared to the others schemes. In addition, for the UEP-MIMO scheme, the overall data system transmission from mode-B outperforms that of mode-G with SNR gains of 8.2 dB compared to the 7.5 dB for the UEP-SISO scheme. Also, MMSE-SPC also outperforms the ZF-SPC with a 3 dB SNR at a bit error rate (BER) of 10⁻³.

Index Terms—Adaptive modulation and coding (AMC), multiple-input multiple-output (MIMO) channel, superposition coding (SPC), unequal error protection (UEP), spatial multiplexing (SM), zero-forcing (ZF) and minimum mean square error (MMSE).

I. INTRODUCTION

Providing high-quality video- and multimedia oriented services is regarded as a task of great importance for enhancing the next generation of wireless broadband communication systems. However, effective video data transmissions are highly sensitive to errors over time-varying wireless channels, which has become the major challenge. The data priority (high-priority (HI) and low-priority (LI) subchannels) can be categorized as mode-B (HI only) and mode-G (HI and LI). Thus, it is important to investigate what actually occurs when making a video call, for example, in real-time video conferencing, to

obtain a thorough and general understanding of this phenomenon. In this process, the user's face, which is taken in the foreground, is part of the high-importance (HI) data layer, whereas the background scene reflects the low-importance (LI) data layer "Ref. [1], [2]". There is a priority to transmit more reliable HI data than LI data, which is one requirement for optimising the quality of service (QoS). Hence, it is more important to protect the HI data than the LI data from being corrupted by the channel. In the last decade, there have been an increasing number of emergent plans or schemes devoted to develop error control schemes in the field of wireless communication. One of these schemes is known as UEP, where the original and initial proposal of this scheme was for single-carrier systems, but there is a potential extension of its use for multi-carrier systems "Ref. [2]". UEP has the ability to divide the data signal into two or more layers based on priorities. For instance, the HI layer carries more of the data signal and can perform self-decoding to reconstruct the original signal. However, the LI layer carries the data of less importance, which are employed to enhance the signal quality. Because errors in the HI layer have adverse impacts on the quality of the reconstructed signal, it is important to reduce the errors as much as possible. In contrast, errors in the LI layer can be tolerated more. Therefore, the goal of UEP is to protect the HI layer as much as possible to achieve a high-quality signal "Ref. [2], [3]". The effectiveness of UEP as a method is related to video transmission in error-prone wireless environments. Its effectiveness is attributed to its ability to protect various parts of the video data with various levels of importance. In its basic function, UEP is capable of making changes in the distribution of errors without consuming additional resources. Thus, the more important data suffers from fewer bit errors "Ref. [4]-[6]".

In contrast, AMC is a well-known technique that has gained wide consideration and investigation in the recent literature on wireless communication systems. It is also recognised as an effective link adaptation technique, which has been widely applied in wireless communication systems for the last few years "Ref. [7], [8]". The AMC technique permits the systems to select the most suitable modulation and coding scheme (MCS)

Manuscript received November 28, 2018; revised July 3, 2019.
Corresponding author email: waheb@ieee.org.
doi:10.12720/jcm.14.8.696-705

that best fits the instantaneous channel quality, therefore selecting the MCS with a higher modulating order and coding rate to maximise the transmission data rate, and vice versa for low-quality channels. Thus, different MCSs will be utilised for different channel conditions, so that, an optimal performance in terms of both bit error rate (BER) and data rate can be achieved “Ref. [9]”.

However, SPC modulation is considered as an alternative method to the other coded modulation techniques with bandwidth efficiency. In SPC modulation, the linear superposition is made for the number of encoded layers before the transmission “Ref. [10], [11]”. In the SPC modulation scheme proposed by “Ref. [12]”, the various bit streams are transferred on the same modulation periods. The authors in “Ref. [13]” proposed a SPC modulation scheme that utilises block codes as its component code, which is known as superposition block coded modulation. These researchers reported a significant gain from low encoding and decoding complexity with the proposed scheme.

This paper proposed an effective AMC technique, which employs UEP-SPC scheme for transmitting the data through the wireless fading MIMO channel. The proposed system in this paper aims to provide a reliable quality of reception for even the lowest-quality channels through the exploitation of the layered data and instantaneous CSI. However, the proposed scheme is capable of delivering diverse data signal layers over MIMO wireless channels along with different protection levels in an adaptive manner that depends on the SNR of the reception. The results obtained from the simulation revealed that the proposed system has efficiently and significantly improved in the execution of the wireless data transmission systems through MIMO channel compared to the single-input single-output (SISO) and Single-Input Multiple-Output (SIMO) systems. Furthermore, the study showed that flexible trade-offs in terms of execution improvement between the HI and LI data layers in addition to the overall (HI + LI) data system can be achieved by making adjustments to the modulation power fractions of the layers. Finally, a lower BER can be obtained when the superimposed signal transmission has a uniform constellation.

In addition, Spatial Multiplexing (SM) is the one type of the MIMO techniques that used to significantly increase the data rates (enabling high spectral efficiencies) or channel capacity. SM is achieved by transferring various data streams on the same time-frequency grid “Ref. [14]-[16]”. However, in SM-MIMO technique, the data stream is subdivided into independent sub streams, one for each transmitting antenna. Therefore, in a SM configuration, which that focuses on the current study, the system is capable of obtaining substantial gains in the data rate, and such a scheme can be use with or without the transmission of channel knowledge “Ref. [17]”. The standard linear RSC detection methods that are used on

the receiver side include the ZF and MMSE techniques. However, both of ZF and MMSE are considered in the simulation work.

The rest of the paper is organised as follows: The proposed UEP-AMC-SPC-MIMO system is discussed in section 2, where the system design for two modes of operation, mode-G and mode-B, is highlighted. Section 3 presents and discusses the performance evaluation of the proposed system, and section 4 provides the simulation results and discussion for the proposed system with the OSIC. Finally, section 5 is drawn the concluding remarks of this paper.

II. PROPOSED UEP-AMC-SPC-MIMO SYSTEM MODEL

“Fig. 1,” illustrates the block diagram of the proposed transmission system employing UEP, which is based on sub channel partitioning. For a simple illustration, the diagram will present only the functional blocks that are related to data transmission; the blocks that are related to the feedback are omitted. As observed on the transmitter side, the source data of the adaptive transmitter stage are split into several various priority layers based on the priorities of the data, i.e., the quality of the reception. Because the proposed scheme has the ability to support the data at different layers, we implemented a system with only two data layers for simplicity in the analysis, namely, (i) the HI data layer, which comprises the more important data, and (ii) the LI data layer, which comprises the less important data. In contrast to the LI data layer, a higher level of protection against propagation errors will be emphasised in the HI data layer during the data transmission because these errors have a significant effect on the quality of the data. Then, each layer is encoded and modulated separately by utilising AMC, which is subject to the CSI. Therefore, the CSI-based AMC is used here to encode and modulate each data layer individually. In the encoding stage, these two layers are encoded with an adaptive forward error correction (FEC) code to produce the HI and LI code words, v_{HI} and v_{LI} . In the modulation stage, these code words are modulated with the adaptive modulation (AM) order, and the level of UEP for each priority layer is used to protect the layer from error transmission.

The various UEP levels are equipped with the v_{HI} and v_{LI} code words by assigning various power ratios, α_{HI} and α_{LI} , of the overall transmitted power, P . Thus, the various modulated power ratios are assigned to the various priority layers, where modulation of a higher-priority data layer with power ratio is higher than data layer of a lower-priority. In addition, the power ratio of each layer is provided in accordance with its priority, i.e., $\alpha_{HI} > \alpha_{LI}$. Therefore, the total average power ratio for modulating bit streams is assumed to be one and can be stated as follows:

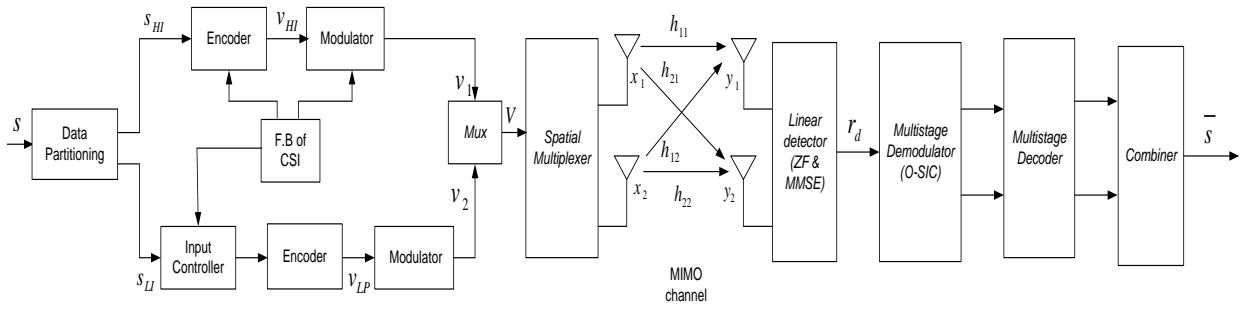

Fig. 1. Block diagram of the proposed UEP-AMC-SPC-MIMO system model.

$$\alpha_{HI} + \alpha_{LI} = 1 \tag{1}$$

where

$$\frac{P_{HI}}{P} + \frac{P_{LI}}{P} = 1 \tag{2}$$

Therefore,

$$P = P_{HI} + P_{LI} \tag{3}$$

where P_{HI} and P_{LI} are the power utilised in the HI and LI modulators, respectively. This criterion results in transmitting the data of the highest-priority layer with the highest reliability and those of the lowest-priority layer with the lowest reliability. To construct the transmission signal, the adaptive modulated signals of two layers are then superimposed, which can be illustrated as follows:

$$V = \sum_{n=1}^2 v_n \tag{4}$$

Therefore, to avoid losing generality and to achieve transmission of high spectral efficiency, the scheme proposed in the current study is operated by using two system modes, namely, mode-G and mode-B, which will be introduced based on the output of the CSI feedback signal (CFS). The MCS will be chosen according to the wireless channel quality or received SNR. Thus, depending on the CFS, the proposed system switches the modulation order and coding rate to match with the immediate channel quality. Therefore, at the receiver, the SNR is estimated and sent back to the transmitter through the feedback channel using the CSI signal. Thus, mode-G and mode-B are selected by the CFS when the CSI signal displays the SNR of the received signal placed between the designed SNR thresholds of SNR_1 and SNR_2 , where $SNR_2 > SNR_1$. The range of the received SNR is split into several regions using a set of threshold values. The values of the SNR thresholds are selected depending on the BER_{target} of the application, which is a real-time video application in this case. Therefore, depending on the SNR range that assesses the current SNR, the MCS of the proposed system is switched to preserve the BER of the system such that it remains below the target BER.

Therefore, mode-G is selected when $SNR \geq SNR_2$, where it represents a default mode. Alternatively, mode-G is selected when a good CSI feedback signal is received, i.e., high-quality channel. During the initial

transmission, the system is assumed to be in mode-G operation. Thus, the MCS is chosen with a higher modulation and coding rate. Reliable decoding of both the HI and LI bit streams is achieved when the operation of the system is in mode-G. However, mode-B is selected when $SNR \leq SNR_1$; therefore, it is selected to indicate a low-quality channel or lack of a CSI feedback signal. Thus, the MCS is chosen for this system with lower-order modulation techniques, which are highly robust against error without reducing the data rate for the HI layer. Reliable decoding of the HI bit stream only is achieved when the system is operated in mode-B. Then, these two data layers with two various levels of protection are superimposed, and the signal, V , is sent to the receiver with two transmitting antennas over two independent flat Rayleigh fading sub channels by spatially multiplexed MIMO (SM-MIMO) systems. Such systems are able to transmit data at a higher speed than MIMO systems by using antenna diversity techniques. Thus, spatial de multiplexing or signal detection at the receiver side is considered a challenging task for SM-MIMO systems, particularly when the spatial correlation between the receiving or transmitting antenna is very high (a correlation coefficient near unity), which means that signal detection and equalisation at the receiver are impossible. Because each of the independent channels or paths is linked with the corresponding receiving antenna, the received signal at the m -th antenna, y_m , is given by

$$y_m = \sum_{m=1}^2 h_m V_{x_m} + n \quad \text{for } m = 1, 2 \tag{5}$$

where V_{x_m} represents the spatially multiplexed user data signal that is transmitted from the m -th transmitting antenna, is the m -th column vector of the channel matrix H , and n refers to the additive white Gaussian noise (AWGN) with zero mean and a variance of at the m -th receiving antenna. At the receiver side, the received signals, y_m , are then used by the linear detectors, which are capable of retrieving the transmitted vector through MIMO systems. Various techniques can be used to separate the different symbol streams from one another.

These techniques involve the ZF and MMSE as linear receivers, which perform the function of detecting the received signals from multiple antennas and are used to

construct the r_d signal, which is then sent to a multistage demodulator to separate the code word of each m -th layer, $\bar{x}_{(m)}$, from those of the other layers. Moreover, MSD receiver with the OSIC technique is used to reconstruct the two layers of data from the superimposed received signal. This technique is used to enhance the performance without significantly increasing the complexity and separating the layers at the receiver side. It is defined as a bank of linear receivers, each of which functions as a detector of one of the parallel data streams. Thus, the detected signal components are successively cancelled from the received signal at each stage. More specifically, the detected signal from the received signal in each stage is subtracted to use the remaining signal with the reduced interference in the subsequent detection stage.

However, “Fig. 2,” shows the OSIC signal detection process for two spatial streams. Because the system is composed of two layers, the OSIC demodulator involves two stages. It performs the demodulation of each individual data layer according to its priority. Thus, through OSIC, it is possible to use either the ZF or MMSE method to estimate the symbols. In other words, demodulating the signal in the first stage of the OSIC demodulator is performed as follows. Because there are two data layers (HI and LI) in the proposed system, the OSIC demodulator consists of two stages, and it demodulates each data layer separately depending on its priority. Thus, in the first stage of the OSIC demodulator, (the highest-priority layer) will be recovered first by using the first row vector of the ZF weight matrix or with the first row vector of the MMSE weight matrix criterion on the signal.

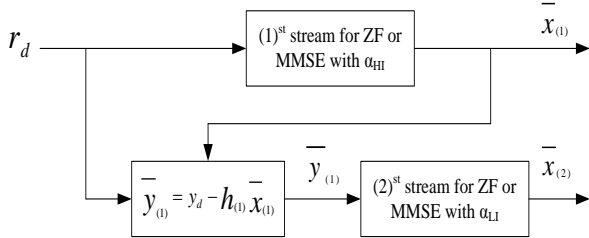

Fig. 2. Explanation of OSIC signal detection for two spatial streams (i.e., NT = 2).

After retrieving the $\bar{x}_{(1)}$ signal, the OSIC demodulator subtracts this signal from the received signal, r_d , to form the remainder of the signal in the first stage, that is,

$$\bar{y}_{(1)} = r_d - h_{(1)} \bar{x}_{(1)} \quad (6)$$

This result will be utilised in the second stage to retrieve the second-priority layer of the signal. This process is repeated successively to retrieve the data layer with the lowest priority. Thus, $\bar{x}_{(1)}$ and $\bar{x}_{(2)}$ can be derived as follows:

$$\bar{x}_{(1)} = \begin{cases} +\alpha_{HI} & \text{for } r_d \geq 0 \\ -\alpha_{HI} & \text{for } r_d < 0 \end{cases} \quad (7)$$

$$\bar{x}_{(2)} = \begin{cases} +\alpha_{LI} & \text{for } \bar{y}_{(1)} \geq 0 \\ -\alpha_{LI} & \text{for } \bar{y}_{(1)} < 0 \end{cases} \quad (8)$$

Therefore, the general formula to retrieve the modulated signal for the m -th layer is given by:

$$\bar{x}_{(m)} = \begin{cases} +\alpha_m & \text{for } r_d - \sum_{j=1}^{m-1} h(j) \bar{x}(j) \geq 0 \\ -\alpha_m & \text{for } r_d - \sum_{j=1}^{m-1} h(j) \bar{x}(j) < 0 \end{cases} \quad \text{for } (m = 1, 2) \quad (9)$$

Equation (9) thus shows that the procedure of retrieving the $\bar{x}_{(m)}$ signal uses the signal of the lower-priority data layer, $h(j) \bar{x}(j)$, as Gaussian interference. The separated data layers are then decoded and combined with a data layer combiner (shown in Figure 1) to reconstruct the original data signal. In addition, perfect channel knowledge on the transmitter side is assumed. The channel model used in this simulation is based on an independent, identically distributed (i.i.d.) frequency-flat Rayleigh fading MIMO channel with AWGN. To avoid any loss of generality, we employed simple block codes in our AMC. Therefore, the FEC code using cyclic codes with encode rate (7, 4) were considered for simulation purposes. The total average power is assumed to be one throughout this simulation.

For a high-spectral-efficiency transmission, the signal, V , is sent via two transmitting antennas. Each of these independent channels or paths is associated with a corresponding receiving antenna. The receiving signals of independent paths, y , will be used by linear detectors that are able to retrieve the transmitted vector through the MIMO systems to construct the r_d signal. At this stage, two linear receiver techniques, ZF and MMSE, are considered to detect the received signals from multiple antennas. The r_d signal is then sent to a multistage demodulator to separate the two layers using the OSIC technique. Therefore, the OSIC technique with a multistage decoder receiver is employed to reconstruct the two-layer data from the superimposed received signal. However, the simulation results validated this theoretical derivation through performing an extensive computer simulations using Matlab R2012 to prove the performance of the proposed system.

III. PERFORMANCE EVALUATION OF THE PROPOSED SYSTEM

In this section, the execution of the proposed system is analysed by considering the bit stream from the data

source that will be divided into two various data streams based on their priorities. Thus, the data source is split into HI and LI bit streams. The encoding and modulation of both streams are performed with different MCS levels to obtain a better match with the instantaneous channel quality to achieve a BER below the target level (BER_{target}). By adjusting the power ratio allocations of the data layers, the performance of the overall data can be achieved in a flexible manner. For protection against transmission errors, the proposed system identifies a UEP level for each priority layer in the modulation stage. Therefore, the various UEP levels are submitted by assigning various modulated power ratios for the various priority layers. Thus, the higher-priority data layer is modulated with a higher power ratio and transmitted with higher reliability and vice versa. As a result of this process, the adaptive modulated signals are superimposed to produce the signal that is transmitted in a flat Rayleigh fading MIMO channel. Therefore, it is important to select these power ratios carefully on the transmitter side to satisfy the system design requirements.

“Fig. 3,” shows the comparison of the SNR requirement for a target BER of (10^{-3}) as a function of the power ratio. When the power ratio increases, a lower SNR is required to achieve a BER of (10^{-3}) until the power ratio reaches a value of (0.8). However, power ratios larger than (0.8) require a greater SNR, although not as large as for a power ratio of (0.55) because when the power ratio increases, the effect of the spatial correlation and the loss of spatial diversity can be reduced. We can adjust the power ratio allocations on the transmitter side of the HI, LI, and overall data layers to achieve the trade-offs among these data layers in a flexible manner. Therefore, “Fig. 3,” shows that the best value for the HI power ratio to satisfy the system design requirements is (0.8). Furthermore, if the difference between the HI and LI ratios is increased, the proposed scheme will perform better. Thus, the proposed system will perform better at a high UEP level, where the gain for the HI stream is increasing, and vice versa. Thus, during the course of the simulations, two power ratio pairs were employed to modulate the HI and LI bit streams, (0.65, 0.35) and (1, 0) and were then compared with the best power ratio (0.8, 0.2). As a result, the system is expected to be in mode-G at the initial stage of the system operation or when the feedback signal of the CSI from the receiver displays a high-quality channel. Therefore, mode-G utilises the (0.8, 0.2) and (0.65, 0.35) pairs of the power ratios, whereas mode-B sends only the HI bit stream and thus uses the power ratio pair (1, 0). However, to achieve UEP levels in mode-G, the overall transmitted power, P , is divided unequally between the HI and LI bit streams in the modulation stage, where the power ratios that are assigned to the HI and LI bit streams become (0.65,0.35) for the first state and (0.8,0.2) for the second state.

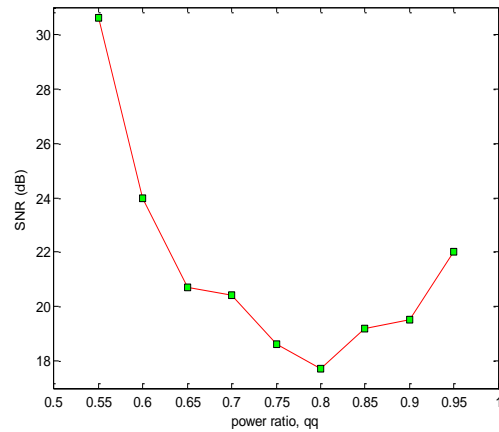

Fig. 3. SNR performance for various power ratios at a target BER of 10^{-3}

“Fig. 4,” illustrates the BER performance of the proposed scheme. The average curves of the HI and LI bit streams are shown for mode-G and mode-B. The BER performance of the proposed scheme for both AMC modes over three different power ratio settings, (0.65, 0.35), (0.8, 0.2), and (1,0) are shown in this figure. Based on these results, it is clear that the HI, LI, and overall data layers display almost similar performance at the UEP scenario of (0.65, 0.35). However, when the power ratio is (0.8, 0.2), the performance of the curve of the HI data layer is better than that of the LI data layer with a (2.4) dB gain in SNR, which implies that the performance of the HI data layer is proportional to its transmitted power ratio. Because of this processing is exclusive to the overall data layer, the overall data system transmission from mode-B outperforms that of mode-G with SNR gains of (8.2) dB at a BER target of (10^{-3}). In addition, the overall data transmission from mode-B outperforms the equal power allocation conventional quadrature phase shift keying (QPSK), 16-quadrature amplitude modulation (16-QAM), and 64-QAM schemes with SNR gains of (20.17, 23.17 and 26.67) dB, respectively. Moreover, as indicated in this figure, $SNR_2 > SNR_1$ and therefore the SNR_1 and SNR_2 threshold values can be determined to be (4 and 12.4) dB, respectively, at a BER target.

For comparison with the SISO system, “Fig. 5,” explains that if the channel is of high quality, the system switches to mode-G of operation. In mode-G, the FEC of the cyclic (15, 11) code is used to encode and decode both the HI and LI bit streams. As displayed in this figure, the performance of the SPC for the HI and LI bit streams with the UEP technique is conducted for two different scenarios of the UEP or power ratio pair, such as; (0.65, 0.35) and (0.8, 0.2), where it is important to assign the different power ratios of P to the HI and LI bit streams. Thus, when determining the rate of the system performance using mode-G operation, it is estimated to be 18.7 dB less overall when the power ratio (0.8, 0.2) is

used compared to the power ratio (0.65, 0.35), which is (20.8) dB when the channel is of high quality at a (BER = 10^{-3}). However, when there is no feedback signal detected or in the case of a low-quality channel, the system switches to mode-B operation. Therefore, the system proposed in this work will be exclusive to transmitting and decoding the HI bit stream. Consequently, it is expected that no effect is exerted by the LI bit stream on the performance of the received data, whereas there will be constant reception for the HI bit stream. Thus, in mode-B, the HI data layer and the overall data will be sent and a UEP power fraction pair is assigned as (1, 0). The results presented in “Fig. 5,” show that the similarity between the BER performance of the HI data layer and that of the overall data system in mode-B. Therefore, as evidenced by these BER curves for the two modes of

operation, it is clear that the aim of the work was achieved by transmitting the source data using an adaptive rate and UEP. However, the overall data system transmission from mode-B outperforms that of mode-G with an SNR gain of (7.5) dB at a BER of (10^{-3}). In addition, the overall data system transmission from mode-B outperforms the QPSK, 16-QAM, and 64-QAM conventional schemes, with SNR gains of (13.5, 16.5 and 20) dB, respectively. Moreover, as indicated in this figure, the SNR₁ and SNR₂ threshold values can be determined to be (10.5 and 18), respectively, at the BER_{target}. From this figure, we see that the two combining approaches with SPC outperformed the approach that did not employ SPC. In addition, the MMSE-SPC outperforms the ZF-SPC by a (3) dB gain at a BER target.

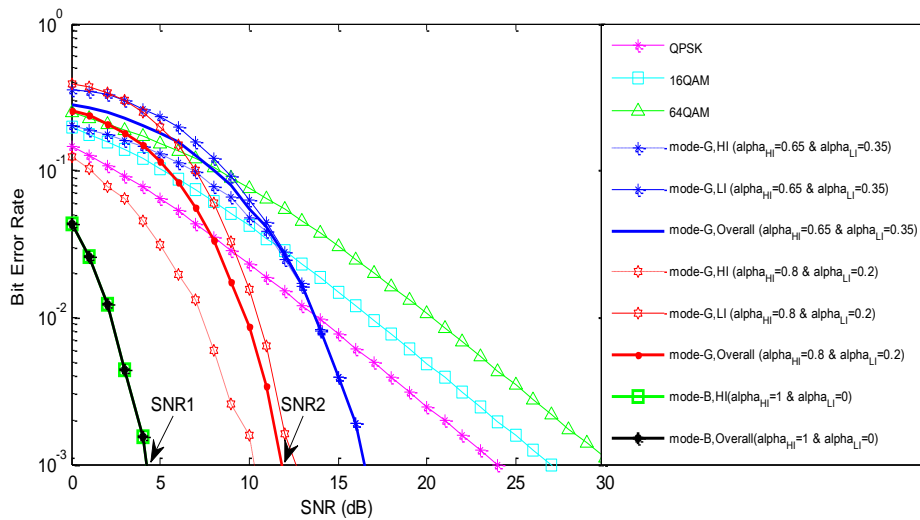

Fig. 4. BER performance of the HI, LI and overall data layers in mode-G and the HI and overall data layers in mode-B for two UEP scenarios over a Rayleigh fading MIMO channel for cyclic coding.

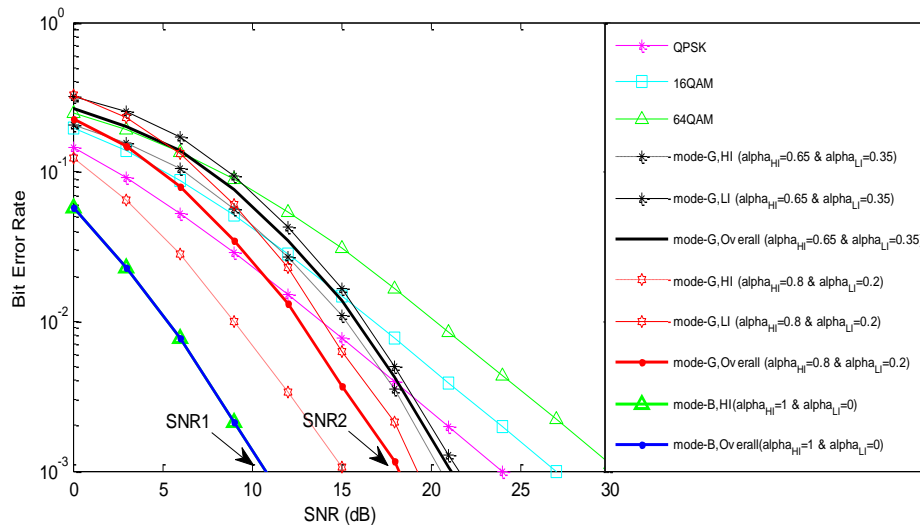

Fig. 5. BER performance of (HI, LI and overall) in mode-G and (HI and overall) in mode-B for two UEP scenarios over a (SISO) channel for cyclic coding.

“Fig. 6,” demonstrates the performance enhancement for the three different systems, SISO, SIMO, and MIMO, which used the same UEP scheme. The performances of these schemes are compared with a single-layer scheme

without UEP. The comparison shows that there is an enhancement for the UEP-MIMO scheme, which always outperforms the other schemes. Therefore, the gap among the three UEP schemes becomes more dramatic when the

number of receiving antennas is increased from one to two. For example, compared to the single-layer scheme without UEP, the enhancement for the UEP-MIMO scheme is approximately (9.4) dB, while it is (8.4) dB for the UEP-SIMO scheme and (6) dB for the UEP-SISO scheme. Thus, with two receiving antennas, the proposed scheme achieves a large performance enhancement compared to the other schemes which demonstrates the ability of UEP to enhance performance compared with the single layer without a UEP scheme that has the lowest performance level.

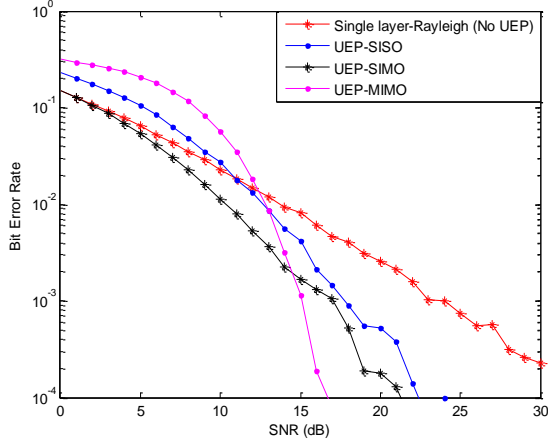

Fig. 6. BER comparison among the single-layer Rayleigh (without UEP), UEP-SISO, UEP-SIMO and UEP-MIMO systems.

IV. EVALUATION OF THE PROPOSED SYSTEM WITH THE OSIC

In this section, we evaluate and compare the BER performance of the proposed system over (2x2) MIMO fading channels with different receiver combining equalisers; such as; ZF-OSIC and MMSE-OSIC equalisers. Because there are two data layers (HI and LI) in the system, the OSIC multiuser demodulates each data layer individually according to its priority to retrieve the signals of these two layers.

“Fig. 7,” displays the BER performance of the proposed scheme with the various combining approaches, such as; ZF and MMSE, as well as compared the results without used SPC over a MIMO channel. However, the two combining approaches without SPC used on the receiver side is considered as the references for comparison. From this figure, we see that the two combining approaches with SPC outperformed the approach that did not employ SPC. In addition, the MMSE-SPC outperforms the ZF-SPC by a (3) dB gain at a BER target.

“Fig. 8,” illustrates the BER performance of the proposed scheme along with the ZF-OSIC equaliser. The performance of the HI layer is better than that of the LI layer for the (2x2) SM-MIMO system. According to these results, the HI, LI, and overall data layers clearly perform better in the UEP scenario of (0.8, 0.2) than the other scenario, such as; (0.65, 0.35). Specifically, when the power ratio is (0.8, 0.2), the performance of the HI layer exceeds that the LI layer with a (13.62) dB SNR at a BER of (0.1). Thus, the execution of the HI data layer is proportional to its transmitted power ratio. In addition, based on the overall data system transmission, mode-B outperforms mode-G.

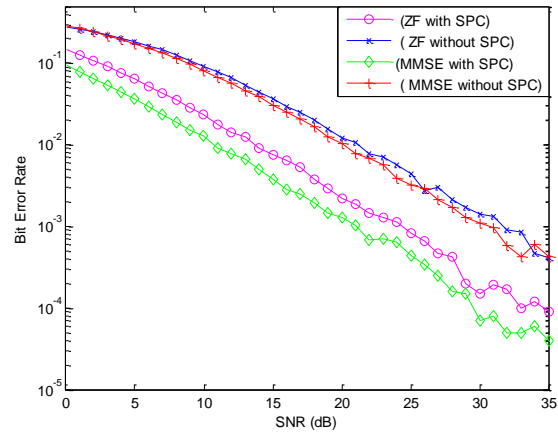

Fig. 7. BER comparison for ZF and MMSE with and without SPC over a MIMO channel.

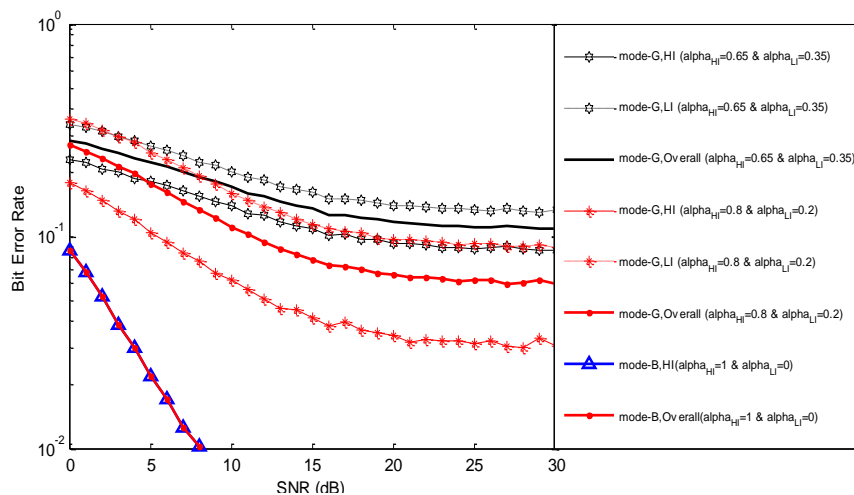

Fig. 8. Comparison of BER analysis of the UEP-SPC-MIMO system of a ZF-OSIC equaliser for mode-G and mode-B

The BER performance of the proposed scheme with the MMSE-OSIC equaliser approach was evaluated, and the results are shown in “Fig. 9”. The HI, LI, and overall data layers outperform the UEP scenario of (0.8, 0.2) in terms of BER. The HI layer outperforms the LI layer by (11) dB at a BER of 10^{-1} . In addition, the BER performance of mode-B is better than that of mode-G. Thus, given the results in Figures 8 and 9, at a low SNR value, the system selects the UEP scenario of (0.8, 0.2), and as the SNR increases, the error rates are continuously reduced, indicating that it is optimal to switch over to the UEP scenario of (0.65, 0.25). Consequently, it can conclude that the proposed scheme performs better when the difference between the HI and LI ratios increases

because of our proposed scheme performs better at a high UEP level, where the gain for the HI stream increases at a high UEP level and decreases at a low UEP level. Finally, it is observed that the MMSE-OSIC equaliser provides a more significant improvement in BER execution for all layers compared to the improvement achieved when the ZF-OSIC equaliser is used.

A summary of the execution comparison of the proposed system with ZF-OSIC and MMSE-OSIC equalisers is provided in Table I. Thus, in both mode-G and mode-B, the MMSE-OSIC equaliser provides (3.5, 12.5 and 4.5) dB SNR gains compared to the ZF-OSIC equaliser.

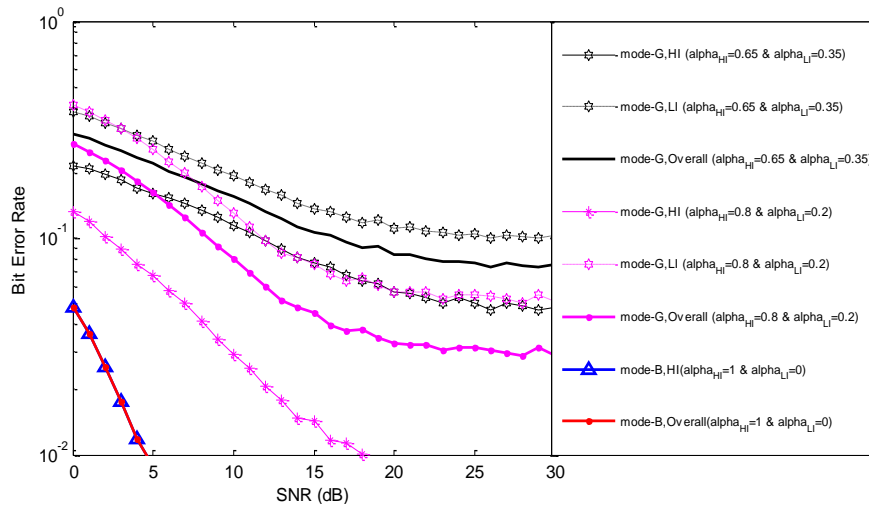

Fig. 9. Comparison of BER analysis of the UEP-SPC-MIMO system of a MMSE-OSIC equaliser for mode-G and mode-B.

TABLE I: PERFORMANCE EVALUATIONS OF THE PROPOSED SYSTEM WITH OSIC AND TWO RECEIVER SIGNAL COMBINER TECHNIQUES (ZF AND MMSE) IN TERMS OF SNR GAINS.

Equaliser	Mode-G		Mode-B
	HI Layer	LI Layer	HI Layer
ZF-OSIC	6	35	8
MMSE-OSIC	3.5	12.5	4.5

V. CONCLUDING REMARKS

This paper proposed an UEP-AMC-SPC-MIMO system for data transmission for next-generation wireless communication systems. This scheme is capable of providing UEP levels against error transmission for diverse valuable data layers according to their importance in terms of impact on the quality of reception over MIMO systems. The aim of the proposed system was to obtain the most appropriate MCS with the quality of the instantaneous channel such that the transmission reliability could be maximised. The study also aimed to provide more guaranteed reception of the higher priority data layer with even low-quality channels. To satisfy these aims and to maintain the QoS at acceptable levels, the proposed scheme is presented in two operating modes: mode-G and mode-B. Through these modes, a flexible adaptation of both the data rate and BER performance as

a function of channel quality was presented. The proposed scheme achieved higher BER performance enhancement compared to the UEP-SISO and UEP-SIMO schemes and the single-layer scheme without using UEP. The simulation results obtained in this study revealed that the proposed scheme achieved significant gains for higher-priority data over the lower-priority data compared to the conventional equal power allocation schemes. Furthermore, based on the obtained results, it is evident that the execution of the HI data layer is proportional to its transmitted power ratio. However, according to these results, the proposed scheme achieves two performance enhancements compared to the traditional techniques. The first improvement is maintaining the HI stream with a high level of protection against transmission errors that may occur during the transmission process, even in the case when a low-quality channel is presented. In contrast to conventional techniques, the results show that there is a continuation in the transmission when utilising the adaptive transmission rate even if the channel is of low quality or there is no feedback signal. This is achieved by switching to mode-B rather than having no transmission with small deviations in BER performance. The second improvement, it is proven that the proposed system resulted in a higher data rate with an acceptable BER for both the HI and LI bit

streams for high-quality channels. In addition, there is no transmission in the traditional schemes for low-quality channels. In addition, MSD receiver accompanied by the OSIC technique is employed using two linear RSC techniques, namely, ZF and MMSE, thus, it is shown that the RSC approaches with SPC outperformed the scheme without SPC.

ACKNOWLEDGMENT

The research was supported by the Ministry of Education, Malaysia under the grant scheme No. FRGS/1/2018/TK04/UMP/02/11.

REFERENCES

- [1] Y. G. Hua, S. Dongxu, and L. O. K. Victor, "Adaptive sub-channel allocation based UEP for video transmission in space-time coded OFDM systems," in *Proc. IEEE 15th International Symposium on Personal, Indoor and Mobile Radio Communications*, vol. 4, pp. 3054-3058, 2004.
- [2] L. Shuying, Z. Yaqin, H. Liang, W. Zhilu, and L. Yuanyuan, "A novel STBC-DCSK transmission scheme for scalable video with unequal error protection property," in *Proc. IEEE International Conference on Consumer Electronics (ICCE)*, 2016.
- [3] H. Changcai and W. Weiling, "UEP schemes for multimedia transmission in space-time coded systems," in *Proc. IEEE International Conference on Communications, Circuits and Systems*, pp. 602-606, 2007.
- [4] L. Yang, Z. Hui, Z. Bin, W. Wenbo, and W. Bin, "A novel unequal-error-protected STBC design for multimedia transmission," in *Proc. IEEE 73rd Vehicular Technology Conference (VTC Spring)*, 2011, pp. 1-5.
- [5] J. Jose and S. M. Sameer, "A new unequal error protection technique for scalable video transmission over multimedia wireless networks," in *Proc. IEEE International Conference on Signal Processing, Informatics, Communication and Energy Systems*, 2015.
- [6] S. O. Hazim and X. Wei, "A novel unequal error protection scheme for 3-D video transmission over cooperative MIMO-OFDM systems," *EURASIP Journal on Wireless Communications and Networking*, 2012, pp. 1-15.
- [7] K. S. Wasan, I. Mahamod, N. Rosdiadee, and E. S. A. Ayman, "Survey of adaptive modulation scheme in MIMO transmission," *Journal of Communications*, vol. 7, no. 12, 2012.
- [8] R. Fantacci, D. Marabissi, D. Tarchi, and I. Habib, "Adaptive modulation and coding techniques for OFDMA systems," *IEEE Transactions on Wireless Communications*, vol. 8, no. 9, pp. 4876-4883, 2009.
- [9] K. S. Wasan, I. Mahamod, N. Rosdiadee, and E. S. A. Ayman, "Throughput performance of adaptive modulation and coding scheme with link adaptation for MIMO-WiMAX downlink transmission," *Journal of Asian Scientific Research*, vol. 2, no. 11, pp. 641-650, 2012.
- [10] T. Jun, P. Li, and M. Xiao, "Superposition coded modulation with peak-power limitation," *IEEE Transactions on Information Theory*, vol. 55, no. 6, 2009.
- [11] H. P. Adam and W. Tianbin, "Superposition modulation: Myths and facts," *IEEE Communications Magazine*, vol. 49, no. 12, pp. 110-116, 2011.
- [12] P. P. Bergmans and T. M. Cover, "Cooperative broadcasting," *IEEE Transaction on Information Theory*, vol. 20, no. 3, pp. 317-324, 1974.
- [13] G. Karabulut and A. Yongacoglu, "Superposition block coded modulation," in *Proc. IEEE Canadian Conference on Electrical and Computer Engineering (CCECE)*, 2013 vol. 3, pp. 1629-1632.
- [14] M. Jan, S. Robert, L. Lutz, G. H. Wolfgang, and H. A. Peter, "Multiple-Antenna techniques for wireless communications - a comprehensive literature survey," *IEEE Communications Surveys & Tutorials*, vol. 11, no. 2, pp. 87-105, 2009.
- [15] R. Fa and R. C. D. Lamare, "Multi-branch successive interference cancellation for MIMO spatial multiplexing systems: Design, analysis and adaptive implementation," *IET Communications*, vol. 5, no. 4, 2011.
- [16] H. Thomas, L. Peng, R. C. D. Lamare, and W. Stephen, "Multi-Feedback successive interference cancellation with dynamic log-likelihood-ratio based reliability ordering," in *Proc. Tenth International Symposium on Wireless Communication Systems*, 2013, pp. 696-700.
- [17] H. Nohand and F. Xavier, "Massive MIMO wireless networks: An overview," *Journal of Electronics*, vol. 6, no. 63, pp. 1-29, 2017.



Wasan Kadhim Saad received the B.Sc. degree in Electrical and Electronic Engineering / Electronic & Communication from the University of Technology, Baghdad, Iraq, 1997. She received the M.Sc degree in the Satellite Communication Engineering from the University of Technology, Baghdad, Iraq, 2005, and her Ph.D. in Electrical, Electronics, and System Engineering from the University Kebangsaan Malaysia (UKM), Faculty of Engineering and Build Environment, Bangi, Selangor, Malaysia, 2017. She is currently working in the Al-Furat Al-Awsat Technical University, Engineering Technical College-Najaf, Iraq. Her research interests include Wireless Communications and Networking, Cognitive Radio Networks and Image Processing.



Waheb A. Jabbar received the B.Sc. in Electrical Engineering from the University of Basrah, Iraq, in 2001, the M.Eng. in Communication & Computer and the Ph.D. in Electrical, Electronics, and System Engineering from Universiti Kebangsaan Malaysia (UKM), Bangi, Selangor, Malaysia, in 2011 and 2015 respectively. He is currently a Senior Lecturer in the Faculty of Engineering Technology, Universiti Malaysia Pahang (UMP), Gambang, Pahang, Malaysia. His research interests include

Routing Protocols in Ad Hoc Networks, Mobile Communications and Wireless Networking. He also has keen interest in Internet of Things applications and Smart City.



Bashar J. Hamza received the B.Sc. degree in Communication Engineering from Al-Furat Al-Awsat Technical University, Engineering Technical College-Najaf, Iraq, 2002. He received the M.Sc degree in the Communication Engineering from the University of Technology, Baghdad, Iraq, 2005, and

His Ph.D in Wireless Communication Engineering from the Universiti Putra Malaysia (UPM), Faculty of Engineering, 2011. He is currently working in the Al-Furat Al-Awsat Technical University, Engineering Technical College-Najaf, Iraq. His research interests include Vertical handover, UMTS network, WLAN network and Heterogeneous network between UMTS/WLAN.