

## Conference Paper

# Application of Discrete Event Simulation (DES) for Queuing System Improvement at Hypermarket

Fazeeda Mohamad and Siti Filza Saharin

Faculty of Industrial Management, Universiti Malaysia Pahang, Lebuhraya Tun Razak, 26300 Gambang, Pahang, Malaysia

## Abstract

This paper focuses on the development of a computer simulation model for improving the queuing system at a hypermarket using Discrete Event Simulation (DES) and to propose the most efficient hypermarket queuing system for overall improvement. Data were collected from the Hypermarket A using the time study. The method of this study is using modeling and simulation. Arena Simulation Software is used to develop the model to replicate the actual system. Three scenarios had been tested, and the alternatives will be ranked based on the level of the efficiency of the system performance. The most efficient queuing system is identified based on the scenario analysis. In this study, the waiting time for each customer can be improved by up to 26%, which equivalent to 5.24 minutes. Overall, this study contributes to a better understanding of the queuing system performance.

**Keywords:** hypermarket, queuing system, waiting time, simulation, Discrete Event Simulation (DES)

Corresponding Author:

Fazeeda Mohamad

fazeedamohamad@ump.edu.my

Received: 5 August 2019

Accepted: 14 August 2019

Published: 18 August 2019

Publishing services provided by  
Knowledge E

© Fazeeda Mohamad and Siti

Filza Saharin. This article is distributed under the terms of the [Creative Commons](#)[Attribution License](#), which permits unrestricted use and redistribution provided that the original author and source are credited.

Selection and Peer-review under the responsibility of the FGIC2019 Conference Committee.

## 1. Introduction

There is a growing demand for the services offered, like getting treatment in the hospital or clinic, post office service, buying goods at the hypermarket and service at the banking system. Waiting line or queue is the normal situations in life, especially in the organization that making a profit (J.S.K.C & T.M.J.A, 2016). This type of services typically requires the customer to queue to be served. If the system management was inefficient, customers will face long queuing and require long waiting times.

As a growing retail industry, system management needs improvement in terms of their efficiency. Malaysia retailing industry is growing due to an increment in terms of hypermarkets available in the country, for instance, Giant, Tesco, Carrefour, and MYDIN (Kar, 2014). Most of the services provided by the hypermarket are related to the queuing problem and waiting time. Majority of the customer experienced long waiting time before getting served. In the retail industry, they recognize that waiting time is one of

### OPEN ACCESS

the important aspects of customer services. Therefore, this problem needs to be solved so that the service provided will increase customer satisfaction.

Nowadays, hypermarkets could be considered as a modern retailing format that provides everything under one roof. Although this concept is similar to the existing shopping center, hypermarkets focus more on fast-moving consumer goods (FMCG) (Hassan, Bakar Sade, & Sabbir Rahman, 2013). The hypermarket has to improve service operations to attract and fulfilling customer satisfaction. Customer satisfaction will give a big impact on the retail industry as contributes to overall performance.

In general, a hypermarket is a place for people to buy household goods and necessities. The hypermarket typically located outside a town with self-service superstore with a variety of products and also providing the car park. By providing a variety of products, it causes the hypermarket to became the focus of the public to buy all the required products in the one outlet. The typical queuing problem is because of several factors such as insufficient checkout system opens, especially during peak hours. This makes the waiting line will be too long, which lead to customer dissatisfaction. Due to this, the quality of the services will be decreased. Based on the previous study, most customer satisfaction lies in car park facilities and a short period for the payment process (Kar, 2014).

According to Xing, Li, & He (2015), there are different ways of handling the queuing problem, which is based on management. Therefore, the management experiences will lead to the decisions since it will be the different volume of the customer within a certain period. Some of the management take action to set the number for cashier opening. However, some of the management making the decisions by providing 'fast cashier' or 'express counter' for the customer that is only buying little quantity of products. Annas (2017) noted that to reduce the waiting times, the management needs to implement strategies to increase the service rate. It can be by adding servers, faster server, automated system, or a combination of these three strategies.

There are two general methods to evaluate the queuing length which affecting in waiting time, such as by applying a queuing theory or using simulation (Kim, Galiza, & Ferreira, 2013). This study will develop the model and analysis by using Arena simulation software. Thus, this model is to mimic the actual system. This simulation and modeling can enhance the level of efficiency of the queuing system without intruding the actual operations in the hypermarket. It is impossible to identify all the factors when the new system completed set up. According to Robinson (2015), Discrete Event Simulation (DES) is commonly used by other researchers in the services sector, such as supermarkets,

banks, and airports. Karnon et al. (2012) verifying that DES is a form of computer-based modeling that provides an intuitive and flexible approach to representing complex systems. DES also as a tool for analyzing the service performance that gives an impact on customer satisfaction (Xian, Hong, & Hawari, 2016).

Hypermarket A facing the similar problem as other researchers have mentioned in their study, which refers to the queuing problem. The queuing problem is due to the insufficient checkout system. There are several checkout systems at the Hypermarket A without standardization. For instance, the checkout system opened to all the customers without emphasizing the volume of the products, the mode of a customer making payment either using cash or credit card. This unstructured system leads to longer queuing time and unorganized checkout system. This contributes to customer dissatisfaction, especially when the customers have to be in the long queue just to buy a small amount of product. Therefore, this study was conducted to look at the possibility of improving the queuing line and the waiting time for the hypermarket under study.

## 2. Literature Review

### 2.1. Hypermarket

The hypermarket is one of the distribution channels that lead to selling product, especially for household necessities. Hypermarkets can also be considered as a normal retailing industry that sells a huge amount and diversity of products within one outlet (Hassan, Rahman, & Sade, 2015). It is confusing to identify differences between hypermarket and supermarket. A study conducted by Hassan et al. (2015) states that the number of hypermarket outlet is expected to constantly increase from year to year. In Malaysia, the retail industry has fierce competition. This is because of government adopted free trade with every developed and developing country. Therefore, many hypermarkets were built by a foreign entrepreneur (Firdaus & Et, 2016). The hypermarket usually located at high population density. The strategy to gain more consumer is by where the hypermarket located. Usually, the target market for a hypermarket is on the working people. So, the hypermarket located near to the workplace which can attract customers to buy after the working hours. Historical review

## 2.2. Queuing Concept

The concept of queues is a common procedure before getting served. A queue is the line of people or objects that are waiting to be operated. The waiting lines are also known as queuing theory. The study about a queue or waiting line is related to queuing theory. It is an important part of the operation and used by operations managers as an appraisal tool. Management can get started with an operational technique as a strategy for decreasing the waiting time (Tom & Lucey, 1995).

Waiting line models are handy for the manufacturing and services industry. In the service industry, a queue is a line of customers that waiting for the service. Almost all services require customers to wait until their turn to get the service. The formations of a queuing are based on some customers need to wait before getting serves. However, there is no queue if the service rates are less than the arrivals rates (Kim et al., 2013). The queue is analyzed in terms of the length of the waiting line, average waiting time, and another factor that used to understand the service system.

In the previous study, single-server with single-phase system and multiple-server with multiphase system usually used for service sectors. The servers are the channel provided in the system, while phases are the number of service stops that must be made. Prasad, V.H, & Koka (2015) noted that multi queue-multi server model as Figure 1 is the design for supermarket and hypermarket systems.

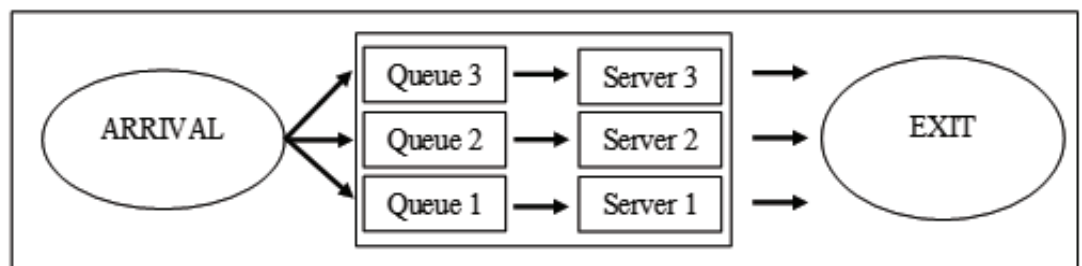

Figure 1: Multi-Queue, Multi-Server (Source: Town (2014)).

Ray & Bunday (1988) acknowledged the queuing theory to measure the performance of the system in terms of the variables. The variables included the volume of customers in the system, a volume of customer waiting, utilization of the servers, response time, waiting time of the customers, idle time in the system. The queuing theory used a mathematical model to analyze the performance of the checkout systems (J.S.K.C & T.M.J.A, 2016).

There are two costs related to the queuing concept, which are the cost of providing service and the cost of not providing service. To attract customer, the management

usually focuses on providing service with the shortest queue for customers. Operation manager requires a short queuing system to ensure high customer satisfaction in the process of buying rather than making the customer leave the checkout system without buying. The improvement in the level of services will reduce the cost of waiting time. Waiting costs are considered as a reflection of the efficiency in the operations.

### 2.2.1. Queuing System

According to Heizer & Render (2014), there are three parts of the waiting line system or queuing system. The queuing system includes arrivals, queuing discipline, and the service facility. The waiting line system is shown in Figure 2.

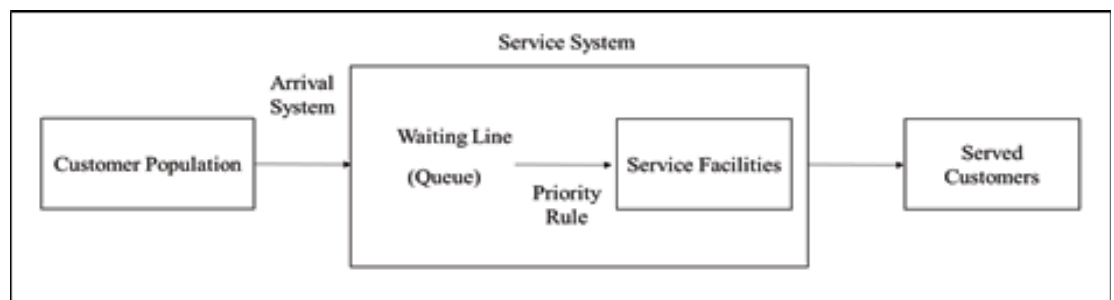

**Figure 2:** Queuing System (Source: Heizer & Render (2014)).

The characteristics for the arrival are the size of the population and the pattern of arrivals at the system. The population is either unlimited (infinite) or limited (finite). This study is the unlimited size of the population because the number of customer arrival at a hypermarket cannot be identified. Next, the pattern of arrivals at the system is either scheduled or randomly. The pattern of arrival is measured based on the number of arrivals. Indeed, the hypermarket pattern is random. It is because the occurrences cannot be predicted.

The queuing discipline refers to a guideline, which is the rule for the customers in the line before getting served. There are First In, First Out (FIFO) rule that customer needs to obey. In other words, FIFO was also known as First In, First Served (FIFS). This rule shows that the first customers in the line will be the first people to receive the services. The FIFS usually used in the service system. However, the other service discipline used is Last In, First Out (LIFO) which the customer comes later will be the first who leaves the system. Service in Random Order (SIRO) also one of the service disciplines which the customers will randomly be selected to be served.

Finally, is the service facility. It refers to the characteristics that including design and the statistical distribution of the time for services. This includes the type of server which

relates to serving rate and serving time. There are three types of customer behavior, such as balking, reneging, and jockeying (Upadhayay, 2017).

### 2.3. Simulation

Simulation is a method for evaluating the behavior of the model with a various situation that allows for making the decision (Ghaleb, Suryahatmaja, & Alharkan, 2015). This simulation requires developing a model that represents the system. Therefore, the simulation will act as an operation of the system. After simulating the model, the real effects of each alternative and actions will be identified. Vaisi, Raissi, & Vaisi (2015) states that it may be important to make improvements in the actual system by using simulation. This is because the whole performance of the system can be assessed.

Xian et al. (2016) state that simulation also can be clarified as a series of 'what if.' The 'what if' is experiments that will be implemented through the simulation. Simulations are of great importance to avoid the failures in the system due to the impact of change. This can be examined without interrupting the working of the actual system through new changes, procedures, information flow in the systems (Sharma, 2015). Modeling assists to understand the behavior of the system and to forecast the effects of changes in the system (Ozgormus, 2015).

Based on Ghaleb et al., (2015), a simulation is experimental of the model that represents real life. It can be studied through the computer simulation how the system operates. The prediction can be made if the variable changed. It also as a tool to virtually investigate the performance of the system. In the previous study mentioned that to improve the performance of service, industries need to use intelligence system such as simulation (Berhan, 2015). The better decision can be made for improving the queuing system if using simulation software. Moreover, there are complex decisions in the service industry since it will involve randomly in customer arrival and time of services.

Discrete Event Simulation (DES) models the operation of a system as a discrete sequence of events in time. Each event appears at a particular present in time and marks a change of state in the system (Sharma, 2015). Due to the changes in the system, this simulation will prevent failure without interrupting the actual system. Robinson (2015) mentioned that DES usually being used in the manufacturing system. However, it has rapidly increased in the service sectors.

According to Karnon et al., (2012), DES provides an intuitive and flexible tool to solve the complex system by using computer-based modeling. Moreover, DES also

can be identified as a flexible modeling method that has the ability to representing complex behavior within, and interaction between individuals, populations, and their environments. Among the simulation methods, only DES provides discrete sequences of the event in time.

### 2.3.1. Simulation Studies for Queuing Problem

In recent years, the research related to the queuing problem has been studied. To solve the problem, several researcher choosing to used discrete event simulation. There are several studies conducted for the queuing problem by using simulation. There is research conducted by Xing et al., (2015) related to simulation and queuing system. Based on their study, there are using simulation as a tool for improving the efficiency of the operation at the supermarket.

The previous study conducted by Xian et al. (2016) examined the service performance, which will affect customer satisfaction. In the study, they aimed to help the management to improve service performance by developing a simulation model. The best alternative will be improving the level of customer satisfaction against the service provided.

The study conducted by Kar (2014) was about the number of parking bays and checkout system. This study applied SAS simulation studio to modeling and analyzed the services provided. In the study, the simulation model is the parking area, normal and express checkout counter. There simulated all the scenarios which included several factors. The factors were based on time, day, shopping pattern, payment mode, and types of checkout system. This study also mentioned that the model would be used as a guide for the process of decision making.

According to Upadhayay (2017), developing a simulation model is needed to make a confirmation against the queuing theory. The study is about bank ATM, which applied to queue theory to reduce the queuing length. This theory requires calculating all the data using the mathematical model. The result also inaccurate because the data involves assumption. In this study mentioned that developing the model of simulation will give reflection to the actual operations compared to the analytical model.

Lastly, a study conducted by Kim et al., (2013) that related to simulation. This study is about modeling pedestrian queuing by using micro-simulation. The model was developed with the details that included travel time, waiting for a time length of the queue, and the number of customers in waiting lines. The main purpose of this study is improving the queue without high costs.

### 3. Methodology

The simulation method requires real data to complete this study. Therefore, this study using observation, interviews, and time study to gather all the information. The information obtained is original data specific for the study. The data taken is related to time and volume. This study needs the data consists of the volume of the customer queuing, and the time is taken for each customer to finished the buying process at the checkout system. The data collected obtain within the data collection period. Data collected must be accurate so that the final results are valid to the system.

Conducting this study require researcher for making plan visit. This is one of the methods to collect the data directly through the Hypermarket A. The data collected through observation at the Hypermarket A for the real customer flows. Observations at the Hypermarket A are required to understand the real situation such as the customer flows and the process of the system. Next, the interview session conducted by interviewing the personnel in charge from Hypermarket A. The personnel in charge are the employees that have more experiences with the Hypermarket A service system. Time study is an important part to get data in terms of time. Therefore, the time of customers in the system was recorded to measure the performance of the queuing system at the Hypermarket A. The time for each customer for completed their process of buying are recorded. Time study needs to be done since this study deal with time.

To view the actual performance, a simulation model was built using Arena simulation software. Moreover, the software also analyses the performance of the current system by using the data collected. This simulation is run for one hour, which is the peak hours at the Hypermarket A. The model was simulated 30 times, which is 30 replications. After running the simulation models, statistical results are collected and recorded to analyze the data. Statistical data produced is in term of the waiting time, the number waiting, and number busy. Those aspects are under performance measurement. Figure 3 shows the standard steps of the simulation process.

The initial step involves problem identification. Identify the problem occurs in the system to be studied. Further defined the requirements for the system and the process to be studied. After problems were identified, the objectives of this study must be established so that the researcher knows the process aimed at this study. Next is to collect and prepare the data. Collect the information on existing system and data needed to conduct the simulation. The data used to formulate the model and run the model using Arena simulation software. If the data did not meet with all the objectives, the process to refine the objectives need to be done. The data also should be recollected



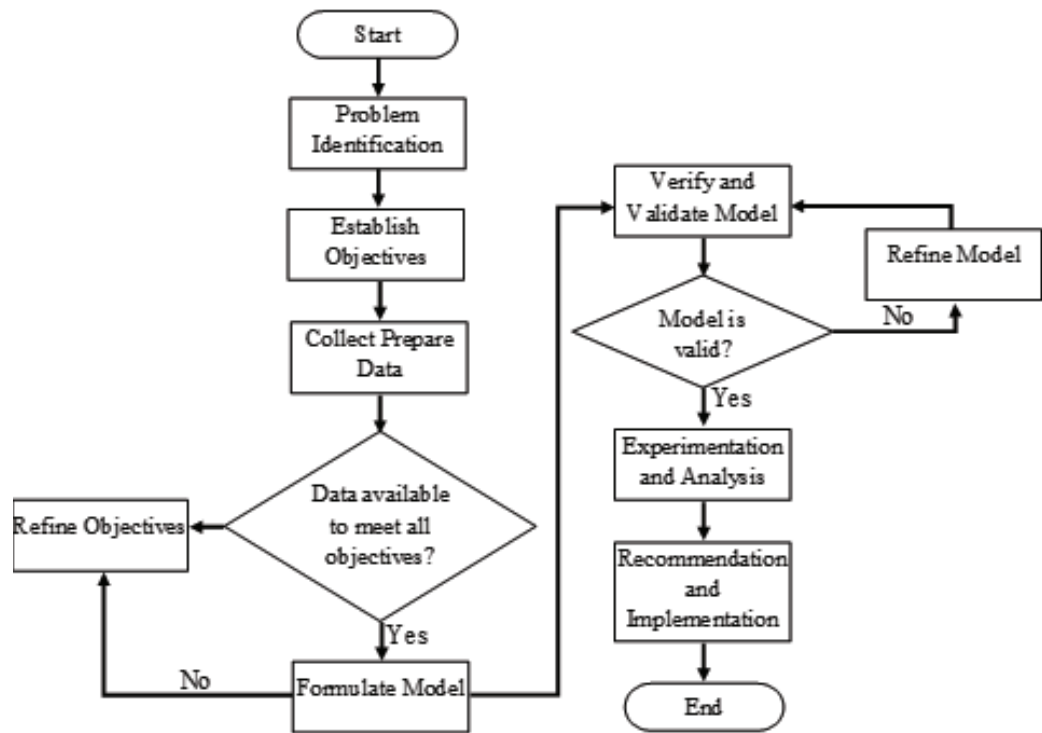

Figure 3: Simulation Modeling Process (Source: Centeno & Carrillo (2001)).

and prepared the model again. Otherwise, if the data available to meet all the objectives, proceed to the formulating model and running the model. To have accurate results in this study, the validation and verification process needs to be done. This process is to ensure that the model is accurate. Verification model is a process of ensuring that the model as intended which computerized model and implementation are correct. The model may be verified but not valid. Validation is to ensure that no difference exists between the model and the actual system.

R. Abdoel Djamali (2018) point out that the validation in this modeling which carried out by comparing the behavior of modeling and real system such as the test of Mean Absolute Percentage Error (MAPE). MAPE is one of the relative measures that relate to the percentage error. This test can be used to determine whether there is suitability between estimation result and actual data. This test can be calculated by the formula below:

$$MAPE = \sum \frac{|X_m - X_d|}{X_d} \times 100\%$$

$X_m$  = data of simulation result

$X_d$  = actual data

TABLE 1: MAPE Percentage and Analysis.

MAPE Percentage	Analysis
MAPE<5%	Very accurate
5<MAPE<10%	Accurate
MAPE>10%	Not accurate

Source: R. Abdoel Djamali (2018)

The next process after validate and verifying the model is conducting a model experiment to improve the queuing system performance. In an experiment, some scenarios have been realized as an alternative to making improvements. In a simulation, implement ‘what if’ analysis is important to improve the system performance. Then, the improvements have been made to improve the efficiency of the queuing system by making changes to the simulation model. Therefore, reducing the risk of the ineffectiveness of the improvement since it only involves computer software. This scenario was developed to see the changes in the result. After that, the recommendation is made for the management to decide on improving the queuing system.

#### 4. Results

There are several processes for the queuing system. Figure 4 shows the process flow of the checkout system at the hypermarket.

This process modeled for mimicking the actual system by using Arena simulation software. The modules that used are CREATE, PROCESS, DECIDE and DISPOSE module. The module is intended to build as a flow chart for introducing the system. Figure 5 shows the queuing system model using Arena simulation software.

The actual system showed that the release volume of customers is 129 people, while the model is 132 people. Therefore, the calculation of MAPE test is carried out. The value of MAPE for this research is 2.33%, which proved that the model is accurate for the next step, which is to perform the ‘what if’ or scenario analysis.

In the simulation, implementing ‘what if’ analysis is important to improve the system performance. Through the simulation model, the impact of the changes can be identified before implementing it in the actual system. Therefore, this can avoid the failures in the system due to the impact of the changes. The scenarios experimentation is important for the management as it contributes to the alternative action to reduce the waiting time at the queuing system in the hypermarket.

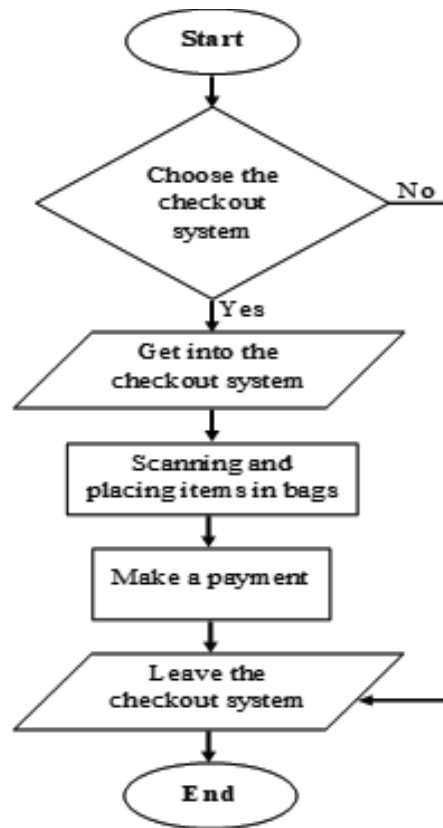

Figure 4: Process Flow of Checkout System at Hypermarket A (Source: Authors' own work).

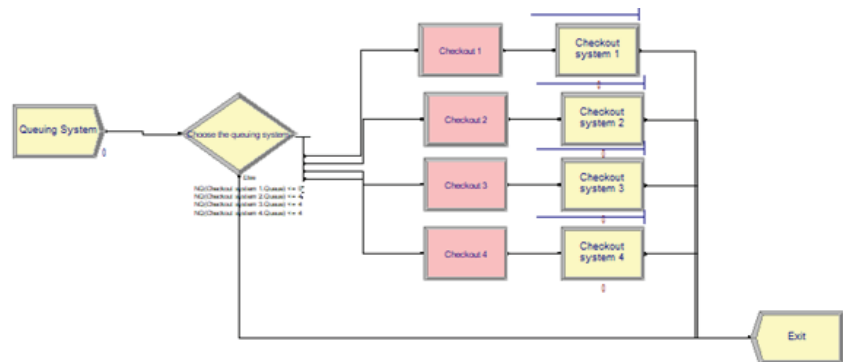

Figure 5: Queuing System Model using Arena Simulation Software (Source: Authors' own work).

In this study, five scenarios to analyze the changes in term of waiting time, number of waiting, and number busy had been conducted. The hypermarket has six checkout system including the express counter. The checkout counter for the hypermarket normally open for four checkout system with three checkout system operate as normal counters, and one checkout system operates as an express counter. Five scenarios have been tested using 'what if' analysis as the following:

1. Scenario 1: Maintain number of customer arrival and open five checkout system

2. Scenario 2: Maintain number of customer arrival and open six checkout system
3. Scenario 3: Increased number of customers and open four checkout system
4. Scenario 4: Increased number of customers and open five checkout system
5. Scenario 5: Increased number of customers and open six checkout system

Table 2 shows the overall results of the system performance between the base case which is the actual system and the scenarios experimentation. The results showed the system performance which is the average waiting time, the average number waiting, and the average number busy for resources usage were improved from the actual system. The increment volume of customers coming in brings to the increasing volume of customer release.

TABLE 2: Results between Base Case and Scenarios.

	Base Case	Scenario 1	Scenario 2	Scenario 3	Scenario 4	Scenario 5
<b>Output (People)</b>	132	132	132	180	180	180
<b>Average Waiting Time (Minutes)</b>	4.9273	3.8961	3.9844	5.1111	4.0363	4.0859
<b>Average Number Waiting (People)</b>	2.1716	1.5726	1.5017	2.2916	1.6465	1.5758
<b>Average Number Busy (Minutes)</b>	0.6808	0.6435	0.6139	0.7004	0.6606	0.6306

In order to recommend the most efficient queuing system, the overall results cannot be the main indicator since there are differences in terms of the aspect of changes for each scenario. Thus, the system performance is defined by referring to the average waiting time for each checkout system and the most efficient queuing system was analyzed. Table 2 and Table 3 showed the analysis in terms of the average waiting time for each checkout system. This shows the average waiting time for the base case and all the scenarios.

In this study, the scenarios for improving the queuing system performance as per suggestion will incur some cost. The costs involved will be either for the recruitment of the cashiers or for the training to improve the cashier efficiency. The overall result shows that the waiting time for all scenarios was decreased except for scenario one as the scenario was conducted to see the effect if no additional check out system open when the number of customer arrival was increased. It means that by opening up one

TABLE 3: Average Waiting Time for Base Case and Scenarios.

Average Waiting Time (Minutes)	Checkout system	Base Case	Scenario 1	Scenario 2	Scenario 3	Scenario 4	Scenario 5
		Checkout system 1 (Express counter)	0.0935	0.0900	0.0895	0.0937	0.0911
	Checkout system 2	7.3481	5.2477	4.8391	7.5257	5.3529	5.0286
	Checkout system 3	6.8971	4.8440	4.5985	7.1471	4.9853	4.5642
	Checkout system 4	5.3705	3.7062	3.5087	5.6778	4.0620	3.6976
	Checkout system 5	-	5.5924	5.2770	-	5.6902	5.4377
	Checkout system 6	-	-	5.5933	-	-	5.6976

checkout system, the overall waiting time for each customer can be decreased up to 21% which is equivalent to 1.03 minutes.

Among the scenarios suggested, scenario 2 was found to be the best strategy to be proposed. If the management implement scenario 3, there will only spend some expenses for recruitment of the cashier for checkout system 5. In addition, if the management implement scenario 2, the waiting time already showed the positive changes by reducing 20% of waiting time from the actual system. The difference number of waiting time for scenario 2 and scenario 3 was only in a second.

Therefore, scenario 2 is the best alternative to be proposed for the management to be implemented for this case. Despite the increased associated with the opening of an additional checkout system, it can reduce the waiting time for each customer. The improvement of scenario 2 is better as compared to the other two scenarios as it will incur lower investment with additional only one cashier.

Even though when the number of customers increased, still by adding up one additional counter as in scenario 4, the average waiting time for the customer still will be decreased by 21%. Kar (2014) mentioned that maintaining and enhancing customers satisfaction is important factors in providing convenience and efficient services. Therefore, from the analysis, this study can conclude that just by adding one checkout system during peak hours and peak day can help to reduce the average waiting time and reduce the number of queuing in the line.

## 5. Discussion

The waiting time is a common problem faced whether in service or production line. This study focused on the services which are hypermarket queuing system. The service sectors problem, especially at the hypermarket relates a lot with the insufficient checkout

system provided, which will lead to longer waiting time among customers. This situation will bring to customer dissatisfaction and frustration (Xian et al., 2016). There are several processes for the customers to complete the buying processes which are choosing the checkout system, get into the checkout system, cashiers scanning and placing all the items in bags and make a payment before leaving.

Management faced difficulties in deciding whether more checkout system should be added as it will also involve more cost. Therefore, the simulation tool is used as it can identify the problem and suggest an improvement to the management without interrupting the actual system. Other than that, the process of making the decision is quicker and more reliable since the model developed based on the actual system. The analysis of queue considers the length of the waiting line, average waiting time, and other factors that contribute to the system (Heizer & Render, 2014). Thus, the results showed that in terms of system performance which are average waiting time, the average number waiting and average number busy for resources usage are improving from the actual system

In this study, there are five scenarios for improving checkout system performance. The scenarios were based on the number of checkout system opened, and the level of staff efficiency. All scenarios tested considered the alternatives related to the additional number of the checkout system. This recommendation is based on the five scenarios that have been implemented in the simulation model.

## 6. Conclusion and Implications

Hypermarket needs to improve their service operations to attract more customer, earning loyalty, and also fulfilling customer satisfaction. Even though the waiting time and queue is a normal situation in the organization that makes a profit, the improvement is needed to ensure customer happiness. The study of a queuing system comprises five processes which are customer choosing the checkout system, get into the checkout system, scanning and placing items in bags by the cashier, making a payment and leave the checkout system. The problem faced by these processes has been analyzed by using the simulation model. The model was developed and running using Arena simulation software. After that, the model requires the process of validation and verification.

Next, 'what if' analysis was implemented to come out with several scenarios for improving the queuing system. The improvement of the queuing system is through the model. So, the improvement process is not interrupting the actual system. This also

reduces the risk and avoid the failures in the system due to the impact of changing the system. The results of these scenarios are related to the enhancement of the model simulation. Next, the recommendation is made to the management to take action for improving the queuing system. The most efficient queuing system will be proposed to the management.

The most efficient queuing system is by opening five checkout system, which reduces the number of waiting time, number of waiting and increasing the number busy of the resources usage. The whole process for developed the model and analyze the system is done virtually by using Arena simulation software. The modeling and simulation method reduces the risk of changing the real system by doing the scenario analysis using the model developed. However, this study is introducing the simulation to be used to make a quicker and reliable decision.

This research shows that the application of Discrete Event Simulation (DES) as a computer-aided tool can help the management to improve the queuing system at the hypermarket. There is a recommendation for further study which considered to calculate the costing involved while deciding the best scenario. The basic model for this research can be generalized by other hypermarket or retail store that have a similar operating system.

## Acknowledgment

We would like to thank Faculty of Industrial Management and FIM's Governance and Integrity Centre, Universiti Malaysia Pahang for the financial support by sponsoring this paper to be presented in the FGIC 2nd Conference on Governance and Integrity 2019.

## Funding

The authors would like to acknowledge the support of the Faculty of Industrial Management, Universiti Malaysia Pahang in funding this project.

## References

- [1] Annas, M. (2017). Modern Hypermarket Receiving Yard Utilization: The Implementation of a Simulation Model, 2(4), 33–39.
- [2] Centeno, M. A., & Carrillo, M. (2001). Challenges of introducing simulation as a decision making tool. *Winter Simulation Conference Proceedings*, 1, 17–21. <https://doi.org/10.1109/WSC.2001.989898>

[//doi.org/10.1109/WSC.2001.977241](https://doi.org/10.1109/WSC.2001.977241)

- [3] Firdaus, K., & Et, A. (2016). Critical Success Factors of Retail and Wholesale Industry: A Case Study. *International Journal of Supply Chain Management*, 5(2), 94–100. Retrieved from file:///C:/Users/Hp/Downloads/1195-4480-1-PB.pdf
- [4] Hassan, H., Bakar Sade, A., & Sabbir Rahman, M. (2013). Malaysian hypermarket retailing development and expansion. *International Journal of Retail & Distribution Management*, 41(8), 584–595. <https://doi.org/10.1108/IJRDM-09-2012-0085>
- [5] Hassan, H., Rahman, M. S., & Sade, A. B. (2015). Shopping Day and Time Preferences of Malaysian Hypermarket Consumers. *Australian Journal of Business and Economic Studies*, 1(1), 61–68.
- [6] Heizer, J., & Render, B. (2014). *Operations Management: Sustainability and Supply Chain Management*. (D. Battista, Ed.) (11th Editi). Pearson Education, Inc.
- [7] J.S.K.C, P., & T.M.J.A, C. (2016). Analysis of the Sales Checkout Operation in Supermarket Using Queuing Theory. *Universal Journal of Management*, 4(7), 393–396. <https://doi.org/10.13189/ujm.2016.040703>
- [8] Kar, L. S. (2014). An analysis of the number of parking bays and checkout counters for a supermarket using SAS simulation studio. *AIP Conference Proceedings*, 1605, 1195–1200. <https://doi.org/10.1063/1.4887760>
- [9] Karnon, J., Stahl, J., Brennan, A., Caro, J. J., Mar, J., & Möller, J. (2012). Modeling using Discrete Event Simulation: A Report of the ISPOR-SMDM Modeling Good Research Practices Task Force-4 Background to The Task Force. *Value in Health*, 15, 821–827. <https://doi.org/10.1016/j.jval.2012.04.013>
- [10] Kim, I., Galiza, R., & Ferreira, L. (2013). Modeling pedestrian queuing using micro-simulation. *Transportation Research Part A: Policy and Practice*, 49, 232–240. <https://doi.org/10.1016/j.tra.2013.01.018>
- [11] Prasad, V., V.H, B., & Koka, T. A. (2015). Mathematical analysis of single queue multi server and multi queue multi server queuing models: comparison study. *Global Journal of Mathematical Analysis*, 3(3), 97–104. <https://doi.org/10.14419/gjma.v3i3.4689>
- [12] R. Abdoel Djamali. (2018). Dynamic System Invention on the Development of Hulled Agro-industry for Supporting Food Autonomy in Papua Dynamic System Invention on the Development of Hulled Agro-industry, (January), 5–11.
- [13] Ray, W. D., & Bunday, B. D. (1988). Basic Queueing Theory. *Journal of the Royal Statistical Society. Series A (Statistics in Society)*, 151(3), 550. <https://doi.org/10.2307/2983006>



- [14] Robinson, S. (2015). Modelling without queues: Adapting discrete-event simulation for service operations. *Journal of Simulation*, 9(3), 195–205. <https://doi.org/10.1057/jos.2014.21>
- [15] Town, M. (2014). Efficient Queue Management in Supermarkets: A Case Study of, 6(39), 185–192.
- [16] Upadhayay, A. (2017). Bank ATM Queuing Model: A Case Study, (5), 40–45.
- [17] Xian, T. C., Hong, C. W., & Hawari, N. N. (2016). Modeling and simulation of queuing system for customer service improvement: A case study, 040020, 040020. <https://doi.org/10.1063/1.4966087>
- [18] Xing, W., Li, S., & He, L. (2015). Simulation model of supermarket queuing system. Chinese Control Conference, CCC, 2015–Septe, 8819–8823. <https://doi.org/10.1109/ChiCC.2015.7261032>