

PAPER • OPEN ACCESS

Investigation of Fatigue Failure Performance of Ankle Implant Mobile Bearing using Finite Element Method

To cite this article: Rosdi Daud *et al* 2020 *IOP Conf. Ser.: Mater. Sci. Eng.* **815** 012016

View the [article online](#) for updates and enhancements.

Investigation of Fatigue Failure Performance of Ankle Implant Mobile Bearing using Finite Element Method

Rosdi Daud^{1*}, M Z H Jantan¹, H M Ayu¹ and A Shah²

¹Faculty of Mechanical and Automotive Engineering Technology, Universiti Malaysia Pahang, 26600 Pekan, Pahang, Malaysia

²Faculty of Technical and Vocational, Universiti Pendidikan Sultan Idris, 35900 Tanjung Malim, Perak, Malaysia

*Corresponding author: rosdidaud@ump.edu.my

Abstract. The Fatigue of the mobile bearing component of ankle implant became one of the main causes of failure in ankle implant. This paper deal with the investigation of fatigue failure performance of mobile bearing for different gait cycles (normal, dorsiflexion and plantarflexion) using finite element method. The finite element analysis is one of the method to predict fatigue and identify the critical area that have highest contact stress on mobile bearing design of ankle implant. The three-dimensional solid modelling of STAR and BOX ankle implants are constructed using SolidWorks software. The finite element analyses are performed by using ANSYS software. The finite element model of the mobile bearing was analysed using static structural analysis approach. The most critical area on the mobile bearing of ankle implant was found on its middle bottom area. The obtained results also showed that the STAR mobile bearing has the higher life cycle than BOX before fatigue failure occurs. This finding is similar with experimental and clinical result done by previous researcher. Therefore, our Finite Element Model has potential to improve the mobile bearing at the designing stage to be better in future in term of fatigue failure resistance and has longer life span.

1. Introduction

Nowadays, fatigue of the mobile bearing component of ankle implant became one of the main causes of failure in ankle implant which is also lead to its loosening. Loosening of the mobile bearing component of ankle implant also occur because of wear. Previous research did study on the prediction of wear on the mobile bearing component [1, 2]. Wannomae et.al reported that the cyclic contact stress at articular surfaces such as between the polyethylene mobile bearing and metal components in ankle implant, mobile bearing undergoes pitting, delamination and changes in crystal structure resulting in low resistance to wear [3]. The current designs of the ankle implant needs a new improvement or innovation to improve the lifespan of the devices [4]. There has been a renewed interest in several new design of ankle implant component after several disappointing in clinical results of the earlier ankle implant designs [4, 5]. The first type of polyethylene used as mobile bearing material was ultra-high molecular weight polyethylene (UHMWPE) which was popularised by Sir John Charnley in the 1960s with his Low Friction Arthroplasty (LFA). Coupled with a metal bearing, UHMWPE provides a high rate of satisfaction, outcome and survivorship in both total hip replacement and total knee replacement. However, aseptic loosening is dominating ankle implant failures and revision [6]. In reducing the risk of aseptic loosening, UHMWPE is used as a liner material in ankle implant since 1960s. It is maybe due of its superior mechanical properties like high strength, low creep, low friction coefficient and good resistance to fatigue [7]. The wears of polyethylene leading to osteolysis in long term period due to the



development of wear particles which cause bone losses surrounding implants leads to instability and subsequently loosen of the implant components [8]. Major factors that contribute to failure of ankle implant such as are fixation method and component design [9]. In order for the ankle implant to have better function and improvement, it must be good in fundamental to enhance the understanding of postoperative performance. The knowledge is mainly on clinical and radiological assessments and survival rates [10]. However, knowledge to enhance understanding the ankle implant design also can be obtained by investigation using finite element method as be done by many previous researchers in investigation other implant performance or biomechanics [11-15]. Nevertheless, the approach of using finite element method to simulate the life cycle for different gait cycle in mobile bearing components is still lacking. Thus, this paper aim is to investigate the fatigue failure performance of mobile bearing for different gait cycles (normal, dorsiflexion and plantarflexion) using finite element method.

2. Methodology

The metals Co-Cr-Mo (ASTM F-75) was used as tibial and talar components for all the ankle implant models and highly cross-linked UHMWPE was used for the mobile bearing component. As we know the Co-Cr-Mo alloys have great resistant to pitting and crevice corrosion and these alloys have excellent wear resistance properties [16]. Table 1 shows the mechanical properties of ankle implant components.

Table 1. Mechanical properties of ankle implant components.

Properties	Mobile bearing (UHMWPE)	Tibial/Talar (Co-Cr-Mo)
Density (kg/m ³)	940	8768
Young Modulus (MPa)	557	210000
Tensile Strength (MPa)	40	655
Yield Strength (MPa)	25	450
Poisson Ratio, V	0.45	0.29

Finite element analysis recently used to assess the influence on contact pressure and internal stress distribution. An average male body weight of 732 N considered for this study with simple loading conditions applying in static loading. The load was remained the same as the force exerted on the surface of the tibial to generate stress distribution on the mobile bearing. The ankle implant was simulated using different gait cycle by applying dorsiflexion (10° angle) and plantarflexion (25° angle). In case of fixed bearing model, the mobile bearing fixed to the tibial component in neutral position by using 'connector' tool in ANSYS software.

2.1. Geometric Model

A three-dimensional (3D) model of an ankle implant was built using the SolidWorks software. By using SolidWorks software, the 3D model of STAR and BOX implant were constructed based on the dimensions obtained from the previous journal. The STAR and BOX implant were chosen because of the three components were congruence with physiologic ankle mobility. Figure 1 shows the 3D model of talar component, mobile bearing and tibial component of STAR implant.

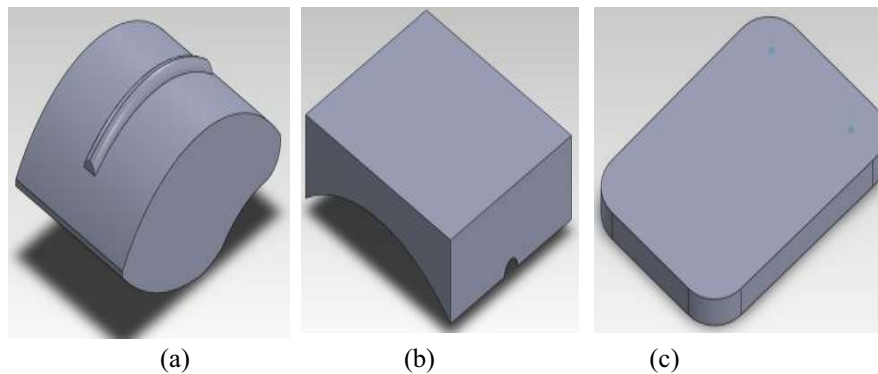

Figure 1. (a) STAR Talar implant (b) STAR mobile bearing and (c) STAR tibia implant

After all three-components of STAR implant was constructed, then it was assembled together by using SolidWorks software. Figure 2 shows completed 3D model of STAR implant.

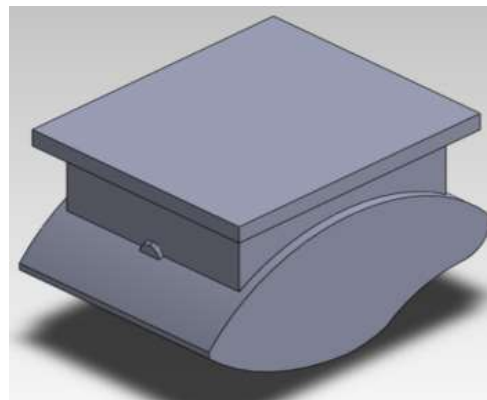

Figure 2. 3D Model of completed STAR ankle implant

Figure 3 shows the 3D model of talar component, mobile bearing and the tibial component of BOX implant.

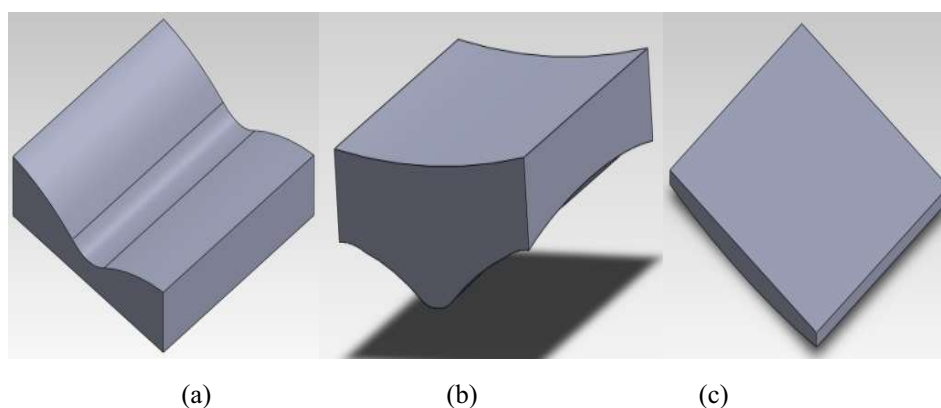

Figure 3. (a) BOX Talar implant (b) BOX mobile bearing and (c) BOX tibia implant

All these models were developed to simulate the right ankle implant. The metal part of tibial and talar components were assigned as Cobalt-Chromium alloy (Co-Cr-Mo) material properties where the Young's modulus of 210 GPa and Poisson ratio of 0.29 were applied to the model. The mobile bearing

component of STAR implants have a concave of 25 mm radius and both bearing on the inferior surface are intact with talar components [17]. The bearing component is ultra-high molecular weight polyethylene manufacture from GUR 1020 with Young's modulus of 557 MPa and Poisson ratio of 0.49.

2.2. Finite Element Analysis of Gait Cycle

The finite element analysis is very useful in predicting the fatigue failure on the mobile bearing. The finite element analysis was done using ANSYS software to get the contact stress in determining the maximum life cycle of the mobile bearing during different gait cycle (normal, plantarflexion and dorsiflexion). The finite element analysis was used to visualize the fatigue failure behavior of the mobile bearing for both STAR and BOX implant.

2.3. Apply Loads and Boundary Conditions

The tibial component was applied the force from the bone and the talar component was fixed at the articulating surfaces of the talar bone. In this simulation, the load created was an axial (vertical) load using concentrated force applied to the tibial component. Figure 4 show the axial force applied to the tibial component of ankle implant.

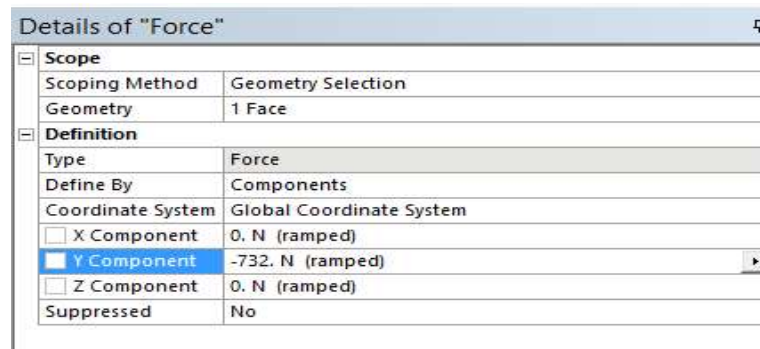

Figure 4. Force applied to the tibial component of ankle implant.

As can be seen from figure 4, the value of load -732 N was applied as the load direction going downward in y-axis while figure 5 shows the fixed part at the bottom of the talar component.

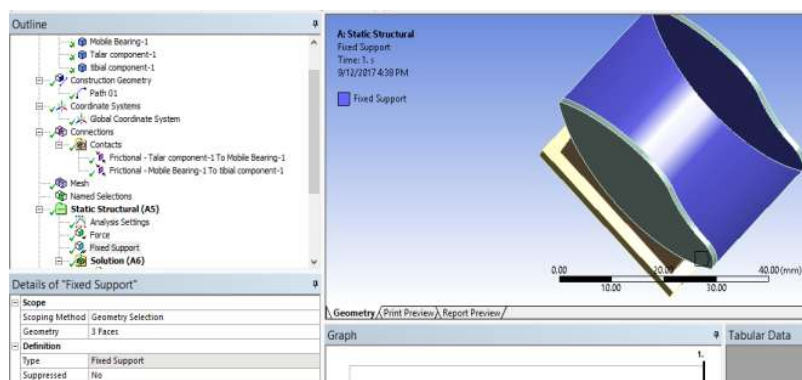

Figure 5. The fixed at the bottom of the talar component

In finite element simulation, the concept of contact and target surface is used for each contact region. One side of a contact region is referred as the contact surface while the other side is referred as target surface. The contact surfaces are restricted from penetrating through the target surface. When one side

is designated the contact and the other side is target this is called asymmetric contact. Figure 6 shows contact surface of mobile bearing with tibial component.

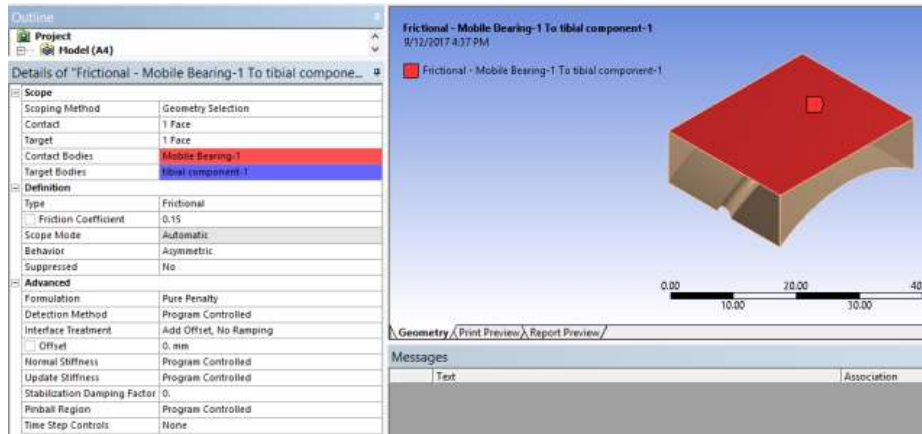

Figure 6. shows contact surface of mobile bearing with tibial component.

From figure 6 show the assemblies in frictional body contact with 0.15 frictional coefficient for both contact of mobile bearing, talar and tibial.

2.4. Mesh the Model

There are hexa, wedge and tetra elements for the solid mesh element available in ANSYS. Tetrahedral element is used in automatic meshing algorithms. Figure 7 shows the mesh of mobile bearing using ANSYS software.

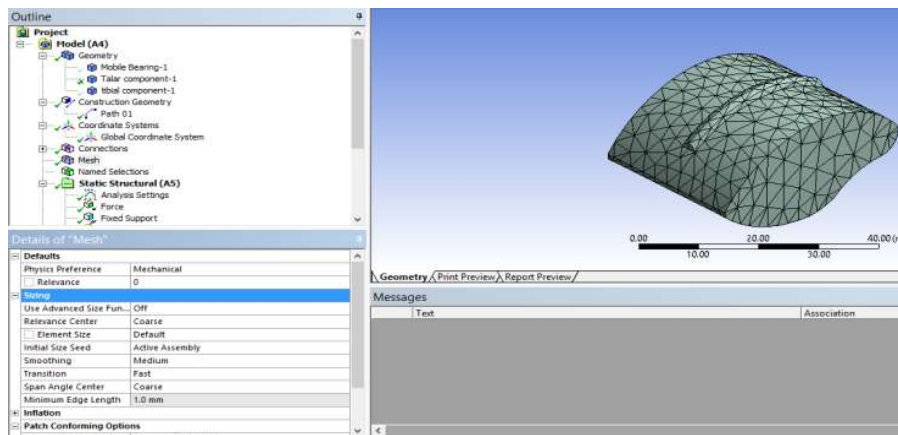

Figure 7. The mesh of mobile bearing using ANSYS software

3. Result and Discussions

Based on FE simulation results obtained as shown in figure 8, the stress Von Mises shows maximum stress of 20.939 MPa exerted at the bottom surface of the mobile bearing during normal gait cycle. During normal gait cycle most of the force exerted on the middle area of the mobile bearing. While, the stress Von Mises shows maximum value 17.603 MPa exerted at the bottom surface of the STAR mobile bearing during dorsiflexion. Most of the force exerted on the upper area of the mobile bearing.

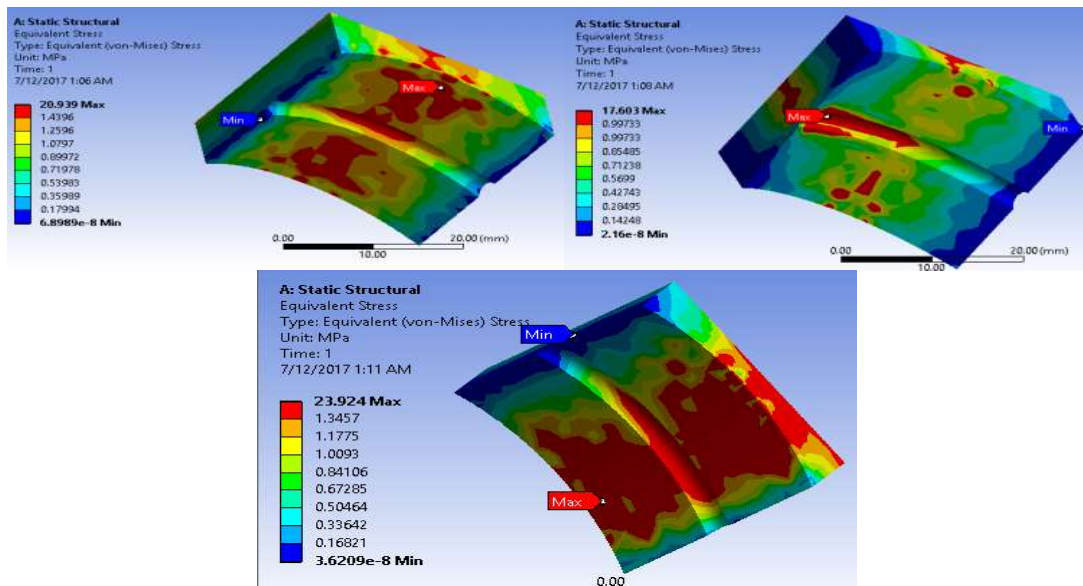

Figure 8. The FE simulation results (stress von-mises) for STAR implant during normal, dorsiflexion and plantarflexion gait cycle

The stress values reach the peak, which is 23.924 MPa during plantarflexion. Most of the force exerted on the lower area of the mobile bearing. However, the stress value during normal, dorsiflexion and plantarflexion are still under the yield strength, thus ensured that the stress relaxation of the material is within acceptable limit. Based on FE results obtain on BOX implant, the figure 9 show the stress Von Mises of 53.962 MPa exerted at the bottom surface of the mobile bearing during normal gait cycle. While, during dorsiflexion gait cycle, stress Von Mises maximum value of 31.129 MPa exerted at the bottom surface of the BOX mobile bearing. The highest value of stress Von Mises, 40.439 Mpa can be seen exerted at the bottom surface of the BOX mobile bearing during plantarflexion. By the way, most of the force exerted on the middle area of the mobile bearing which is can be claimed the most critical region on the mobile bearing.

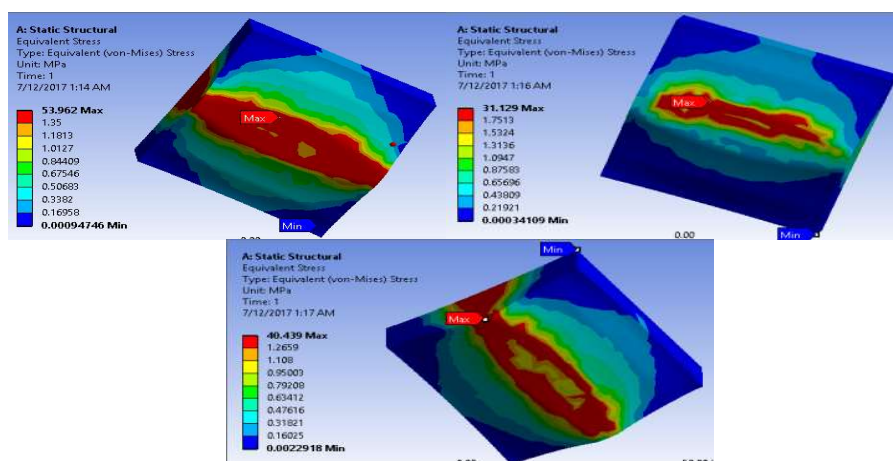

Figure 9. The FE simulation results (stress Von Mises) for BOX implant

Based on the life cycle result obtained as shown in figure 10, the minimum life cycle of 1213.9 is at the bottom surface of the mobile bearing. As we can see, during normal gait, most of critical area is occur on the middle area of the mobile bearing. While, the life cycle result shows minimum life cycle of 941.24 at the bottom surface of the mobile bearing. As we can see, during dorsiflexion, most of the critical area is occur at the middle to upper area of the mobile bearing. The shortest life cycle, 776.87 can be seen at the bottom middle area of the mobile bearing during plantarflexion.

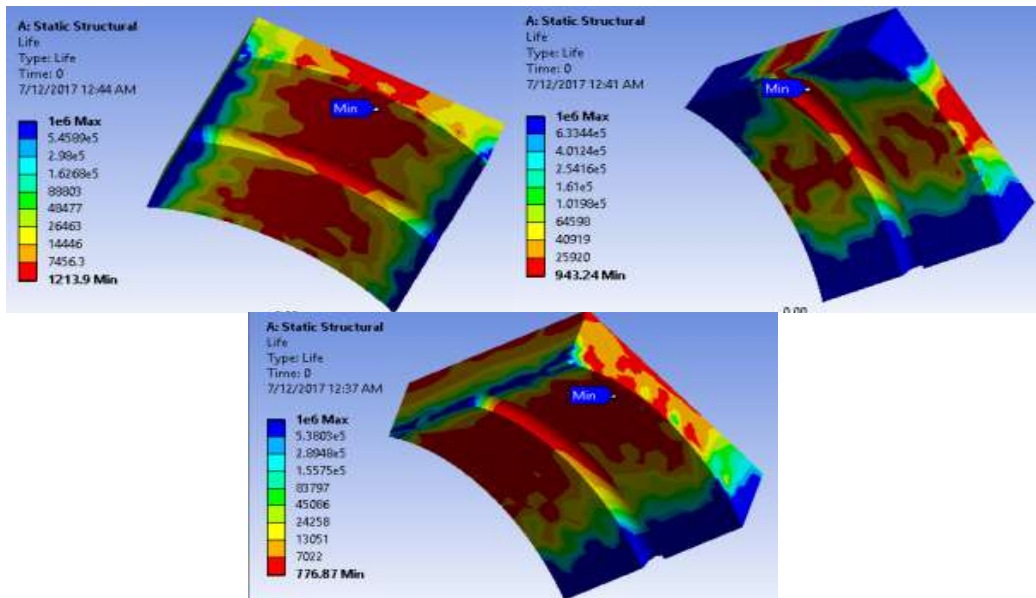

Figure 10. The FE simulation results (fatigue life cycle) for STAR implant

The S-N curve (fatigue limit) of the STAR mobile bearing during plantarflexion is as shown in figure 11. Fatigue limit for plantarflexion is chosen instead of normal or dorsiflexion gait cycle is due to the highest stress value is found during plantarflexion gait cycle.

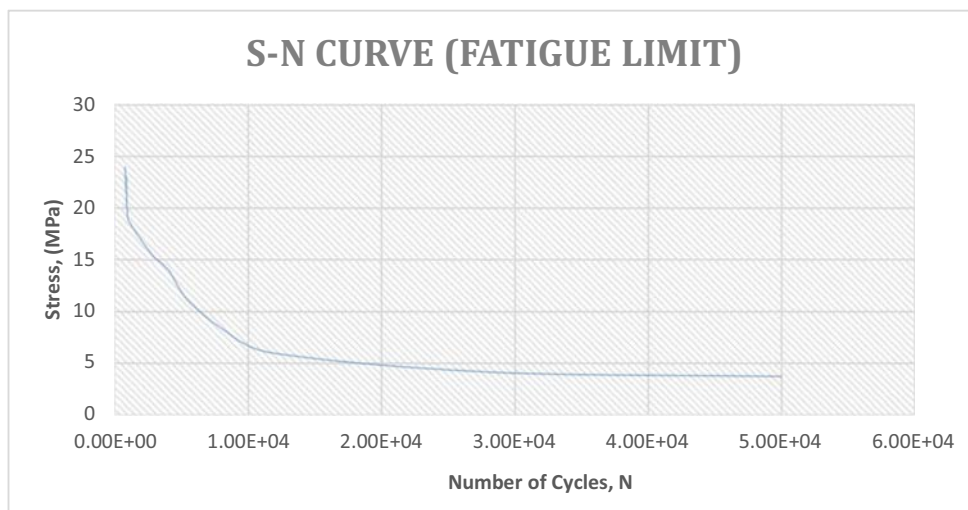

Figure 11. The FE simulation results (fatigue life cycle) for STAR implant

Based on the data shows in figure 11, during peak stress at 23.924 MPa the lowest cycle is 776.87. This finding is in agreement with the previous research that reported due to relatively low yield point and high wear resistance of UHMWPE, the contact pressure acting on the surface causes higher fatigue failure rates in ankle implant [18]. When the higher loads acting on the ankle joint during gait cycle, it generate higher contact pressure which leads to ankle implant failure. Overall, refer to Table 2 we can see that the lowest life cycle of mobile bearing is clearly happen during plantarflexion gait cycle. While, the STAR implant gave highest life cycle of mobile bearing which almost 80% longer than BOX implant. This is maybe due to STAR mobile bearing design is in concave shape, which makes it larger surface area than BOX mobile bearing. While, based on mating surface principle the larger surface area will distribute the loads at the contact to a large amount of body material and thereby induce a more uniform stress pattern.

Table 2. Comparison of Life Cycle of Mobile Bearing between STAR and BOX implant

Life cycle of Mobile Bearing	STAR	BOX
Normal	1213.9	331.78
Dorsiflexion	943.24	243.77
Plantarflexion	776.87	172.67

The success of an ankle implant depends on the design of the implant's mobile bearing itself to overcome fatigue failure to occur. Fatigue is one of the main failure that caused the failure of the mobile bearing on the ankle implants due to cyclic motion in stance phase. Direct comparison of the present results with previous research results is difficult because there is lack of analysis done on fatigue performance of ankle implant mobile bearing.

4. Conclusion

The main objective of this study was achieve since our finite element model able to predict the most critical area which is fragile to the cyclic load during gait cycle (normal, dorsiflexion and plantarflexion). Our FE model is also able to predict life cycle of mobile bearing for both most popular ankle implant, STAR and BOX. Thus, based on the finite element simulation result obtained, we can concluded that the BOX implants have higher potential for the fatigue failure to occur than the STAR implant due to its highest stress approximately 53.96 MPa although during normal gait cycle. If the mobile bearing fails, it leads to the loosening of the whole ankle implant. While, STAR implant showed that it is a reliable choice to use since it has higher life span.

5. References

- [1] A.M.S. Putra et al. 2014 *Advanced Materials Research* **845**
- [2] Nicolo Martinelli, Silvia Baretta, Jenny Pagano, Alberto Bianchi, Tomaso Villa, Gloria Casaroli & Fabio Galbusera 2017 *BMC Musculoskeletal Disorders* **18**
- [3] Wannomae, K.K., Christensen, S.D., Freiberg, A.A., Bhattacharyya, S., Harris, W.H., Muratoglu, O.K. 2006 *Biomaterials* **27**.
- [4] Kathryn O'Connor, Sandra Klein, Patrick Ebeling, Adolph Samuel Flemister, Phinit Phisitkul 2018 *Foot and Ankle Ortho-paedics* **10**
- [5] Cracchiolo A, DeOrio JK 2008 *J Am Acad Orthop Surg* **16**
- [6] S. Giannini, M. Romagnoli, J. J. O'Connor, F. Catani, L. Nogarini, B. Magnan, F. Malerba, Massari, M. Guelfi, 2011 *Journal of Foot and Ankle Surgery* **50** pp 641-647
- [7] Li, S., Burstein, A. H., 1994 *J Bone Joint Surg Am* **76** 1080
- [8] E. Ingham and J. Fisher 2005 *Biomaterials* **26** pp. 1271-1286.
- [9] Nishikawa, M., Tomita, T., Fujii, M. Watanabe, T., Hashimoto, J., Sugamoto, K., Yoshikawa, H. 2004 *Int. Orthop.* **28** pp. 123-126.

- [10] Stengel D, Bauwens K, Ekkernkamp A, Cramer J 2005 *Arch Orthop Trauma Surg* **125**, pp. 109–119
- [11] EL Sin Jian, Rosdi Daud, HM Ayu, MH bin Yusoff, J Jamiluddin, A Shah 2019 *IOP Conference Series: Materials Science and Engineering* **469**
- [12] NMA Azam, Rosdi Daud, H Mas Ayu, J Ramli, MFB Hassan, A Shah, MAHM Adib 2018 *MATEC Web of Conferences* **225**
- [13] Rosdi Daud, Sulaiman Suaidah, H Mas-Ayu, Siti Haryani Tomadi, MS Salwani, Arman Shah, Mohammed Rafiq Abdul-Kadir 2018 *Materials Science Forum* **916** pp.153-160
- [14] FA Zakaria, R Daud, H Mas Ayu, SH Tomadi, MS Salwani, Mohammed Rafiq Abdul Ka-dir 2017 *Matec Web of Conferences* **108**
- [15] Li-Xin Guo, Jia-Yu Yin 2019 *Medical & Biological Engineering & Computing* **57** pp 89–98
- [16] Mitsuo Niinomi 2010 *Metals for Biomedical Devices* (Woodhead Publishing)
- [17] Leardini, J. J. O'Connor, F. Catani and S. Giannini 2004 *Clin. Orthop* **424**
- [18] Reggiani B, Leardini A, Corazza F, Taylor M. 2006 *Journal of Biomechanics* **39**

Acknowledgement

We would like to thank Universiti Malaysia Pahang through research grant RDU180395 for fully support the facilities and resources for this research.