



# INTERNATIONAL JOURNAL ON INFORMATICS VISUALIZATION

journal homepage : [www.joiv.org/index.php/joiv](http://www.joiv.org/index.php/joiv)



## Drivers of Cloud Computing Adoption in Small Medium Enterprises of Indonesia Creative Industry

Andres Gui<sup>a,\*</sup>, Yudi Fernando<sup>b</sup>, Muhammad Shabir Shaharudin<sup>b</sup>, Mazita Mokhtar<sup>b</sup>, I Gusti Made Karmawan<sup>a</sup>, Suryanto<sup>a</sup>

<sup>a</sup>Information Systems Study Program, School of Information Systems, Bina Nusantara University, Jakarta 11480, Indonesia

<sup>b</sup>Faculty of Industrial Management, Universiti Malaysia Pahang, Pahang, 26000, Malaysia

Corresponding author: \*[anderesgui@binus.edu](mailto:anderesgui@binus.edu)

**Abstract**— Cloud computing is one of the enablers of Industrial Revolution 4.0 (IR.40). IR 4.0 is advantageous as it allows companies to increase performance and productivity. However, there are many enablers of IR 4.0, such as big data analytics, cloud computing, machine learning, and blockchain. However, the readiest to be used technology is cloud computing. While the advantages of cloud computing are well understood from the perspective of the literature and companies' point of view, the empirical evidence is still scarce. The research explores the drivers of cloud adoption between small and medium-sized enterprises (SMEs) in Indonesia. The study method is a quantitative method through e-survey data collection analyzed using IBM SPSS and Smart PLS software. The recognition of drivers will allow IT decision-makers to design the right platform for SMEs, increasing their company competitiveness. The findings revealed that cloud flexibility, perceived concern, privacy, relative advantage, perceived cost-benefit, quality of service, and top management support are among the top cloud adoption priorities that need to be improved in the creative industry to ensure the adoption of cloud computing more apparent. The study's contribution revealed that cloud computing is no longer at the infant stage in terms of adoption. Thus, the findings paved the way for scholars to undertake future research focusing on cloud computing implementation. Companies, on the other hand, can learn from this research by improving the adoption aspects.

**Keywords**— Cloud computing; decision making; SMEs; creative industry; industry revolution 4.0.

Manuscript received 20 Nov. 2020; revised 16 Dec. 2020; accepted 2 Feb. 2021. Date of publication 31 Mar. 2021. International Journal on Informatics Visualization is licensed under a Creative Commons Attribution-Share Alike 4.0 International License.



### I. INTRODUCTION

The immense growth in the global creative industry demonstrates a promising market impact. The production of innovative goods and services begins in 2015 at USD 509 billion, compared with USD 208 billion in 2002 [1]. Indonesia's creative sector becomes a new driving force for the country's economy as the trend is similar. Statistics show that Indonesia's creative industry created USD 56.8 billion or 7.3 percent of the goods in the last three years. The new business model implemented by Creative Industries will establish a sustainable Indonesian economy. It was claimed that it would respond to the demands of future ASEAN-free economies. The entertainment field has tremendous business potential. The number of people and the digital revolution propel the business to maximize productivity. Indonesia also has a competitive market that encourages innovative firms to be debated, and the exchange will take place in social media. Consumer demand relative to other countries is considered

vital. The government also plays a vital role in promoting the artistic industries; 16 sub-sectors have been separated based on presidential regulation No 72 of 2015. A creative industry consists of architecture, interior design, graphic design, product design, video animation, illustration, fashion, music, catering, application, television printing, performing arts, and arts [2]. The head of the Bekraf agency, consisting of three sectors covering 16 industries, says that continuous growth, especially in the fashion, culinary, and craft sectors, is expected to enhance Indonesia's creative industries' competitiveness, and technical help will be needed in order to boost business efficiency. There is no consensus, though, how the technologies will function so well for creative industries and the kind of technology they use to increase their business performance. One of the most common innovations discussed recently argued that cloud computing would help the industry foster data storage, security, and management. It would allow the industry to support and cooperate with other manufacturers and business partners. It can be controlled and

assisted by the administration. Understanding the drivers of cloud adoption will help companies and IT specialists build the best software environment for SMEs in the creative industry. They should be able to work on the potential growth of the creative industry.

However, up to now, Indonesia does not have integrated creative industries in terms of development and marketing. The government must encourage the cooperation of any part of the creative industry. According to many companies of Indonesia's creative industries, several challenges such as a lack of selling added value, focusing only on the product, does not adapt to change as required, lack of study, and do not venture to be different are hampering the performance of the company in the industry. The industry's innovative actors are the binding force in improving its sector through increased manufacturing efficiency and improved human capital. Six steps are taken to maximize the innovative industry-workers' hiring procedures, educational development, preparation for employees to achieve expertise, measure and increase teamwork, awards and encouragement, and countless initiatives to improve non-stop programs.

This study suggested cooperation through one of the foundations of Industry Revolution 4.0 to enable the innovative industry to achieve its market success. The use of cloud computing would allow businesses to work more effectively with their supply chain partners [3; 4]. Companies will now exchange critical information quicker in their network, and the introduction of cloud services can save enterprise data storage and management costs. Furthermore, cloud infrastructure allows organizations to spend significantly on business and government technologies, corporate preparedness, and assistance. Research is also proposed on the implementation of cloud computing. Since there are numerous small and medium enterprises (SMEs) in Indonesia, their success will allow the country to expand, and these small and medium-sized businesses will be able to compete with other industries.

## II. MATERIAL AND METHOD

### A. Materials

The independent and dependent variables grouped accordingly. The dependent variable of this study is cloud computing adoption. The independent variables consist of cloud protection, cloud safety, cloud availability, quality of operation, difficulty, compatibility, costs perceived, competitive pressure, top management support, competitive pressure, perceived concern.

1) *Cloud Security*: Security is characterized as a sense of fear of secure data movement and storage through electronic databases and media [5]. Security challenges of cloud computing are generally seen as a question regarding the secrecy, usability, and integrity of data to third parties for cloud users. The confidence levels against host data, which cannot be treated as totally accountable, data leakage, vulnerability virtualization, and hypervisor vulnerability are significant issues relevant to cloud protection. However, cloud hosting platforms are more secure than conventional media storage [6]. Therefore, it can be hypothesized that *Hypothesis 1: Security may positively affect the decision to adopt cloud computing.*

2) *Cloud Privacy*: Privacy is a crucial consideration in implementing clouds representing concerns regarding data collected and accessed in the cloud [7]. The possible lack of power over data stored and used by others without the possibility of data owners being confronted are significant issues related to privacy problems. These issues hinder the usage of cloud storage. However, the cloud service has been developed to enhance better privacy and encryption [8]. Therefore, it can be hypothesized that *Hypothesis 2: Privacy may positively affect the decision to adopt cloud computing.*

3) *Cloud Flexibility*: Cloud flexibility is a feature that can rapidly and efficiently adapt to new market needs [9]. According to [10], cloud services' versatility allows the company system to be distributed over the Internet, which can be viewed at low costs anytime and wherever users. The flexibility capabilities of the cloud service will have a significant effect on cloud usability. For example, Australia's Government and industry advancements provide tremendous flexibility over cloud resources. Moreover, cloud computing offers a range of critical organizational developments through versatile techniques [11]. Therefore, it can be hypothesized that *Hypothesis 3: Flexibility may positively affect the decision to adopt cloud computing.*

4) *Quality of service*: The quality of cloud computing services is critical for consumers' acceptance level. Cloud computing users are demanding a high-quality cloud computing service, as there are abundant service providers. Thus, service quality is one of the fundamental indicators for consumers or users to adopt cloud computing [11; 12]. Therefore, it can be hypothesized that *Hypothesis 4: Quality of service may positively affect the decision to adopt cloud computing.*

5) *Relative advantage*: Cloud infrastructure offers greater creativity to build a plan for strategy effectiveness, revenue development and efficiency. Besides, it reduces the cost of cloud computing when taking into consideration of non-monetary benefits [13; 14; 15]. A relative benefit for cloud usage, which improves resources' availability, automates hardware infrastructure costs, accessibility, possibilities for collaboration, future savings, increased productivity, and administration control [16; 17]. Therefore, it can be hypothesized that *Hypothesis 5: Relative advantage may positively affect the decision to adopt cloud computing.*

6) *Complexity*: Complexity in cloud computing can negatively impact emerging technological advances and can adversely influence SME's efforts to implement cloud computing as it needs preparation to reduce the complexity of cloud computing. Furthermore, the complexity of cloud computing and IT professionals' lack can also contribute to dissatisfaction among consumers [18]. Therefore, it can be hypothesized that *Hypothesis 6: Complexity may negatively affect the decision to adopt cloud computing.*

7) *Compatibility*: Compatibility is the view that stable inventions with their present value [18], and it is confirmed that relative benefits, compatibility, and simplicity in innovation can have a positive effect on innovations [19]. If technology is used consistently with an existing program, SMEs are expected to embrace the cloud. If the technology is not compatible, then SME's goal to carry on new technology

that would be compatible. It has proven to be a significant factor in the SME's decision to implement cloud computing as a consequence that the need for improvements to existing structures such as data encryption is separate from the cloud service provider [18]. Therefore, it can be hypothesized that *Hypothesis 7: Compatibility may positively affect the decision to adopt cloud computing.*

8) *Perceived cost-benefit:* The perceived cost-benefits can be described as a result that individuals and organizations view and receive [20]. The cost advantage perceived in the adoption of cloud computing is to minimize upfront costs and hardware maintenance. Also, the software has a positive impact on adopting cloud computing, especially by SMEs with minimal resources. Another benefit of cloud computing is the pay-per-use customer does not have to think about installation and device maintenance costs with the cloud storage service feature [21]. Therefore, it can be hypothesized that *Hypothesis 8: Perceived cost of benefit may positively affect the decision to adopt cloud computing.*

9) *Top management support:* The top management influences the adoption of cloud computing in the ICT organization as it can bind individuals with developments in cloud adoption so that vision improvements in the ICT

organization can indirectly occur [22]. Through support from top management, the IT department, especially in adopting cloud computing, can take place. This practice's result is that the company's operations using cloud computing will support the company's vision and mission. Therefore, it can be hypothesized that *Hypothesis 9: Top management support may positively affect the decision to adopt cloud computing.*

10) *Reliability:* Cloud data reliability can detect faults easily and in time to ensure high reliability in cloud computing [23]. Service compatibility and redundancy schemes always make cloud service secure [20]. Therefore, it can be hypothesized that *Hypothesis 10: Reliability may positively affect the decision to adopt cloud computing.*

11) *Perceived concern:* The business community's perceived concern is providing resources that allow business continuity to use cloud computing. Data lock-in dependency can lead to issues such as not adding data programs or not making data calculations over the Internet in case of a communication disruption [20]. Therefore, it can be hypothesized that *Hypothesis 11: Perceived concern may positively affect the decision to adopt Cloud computing.*

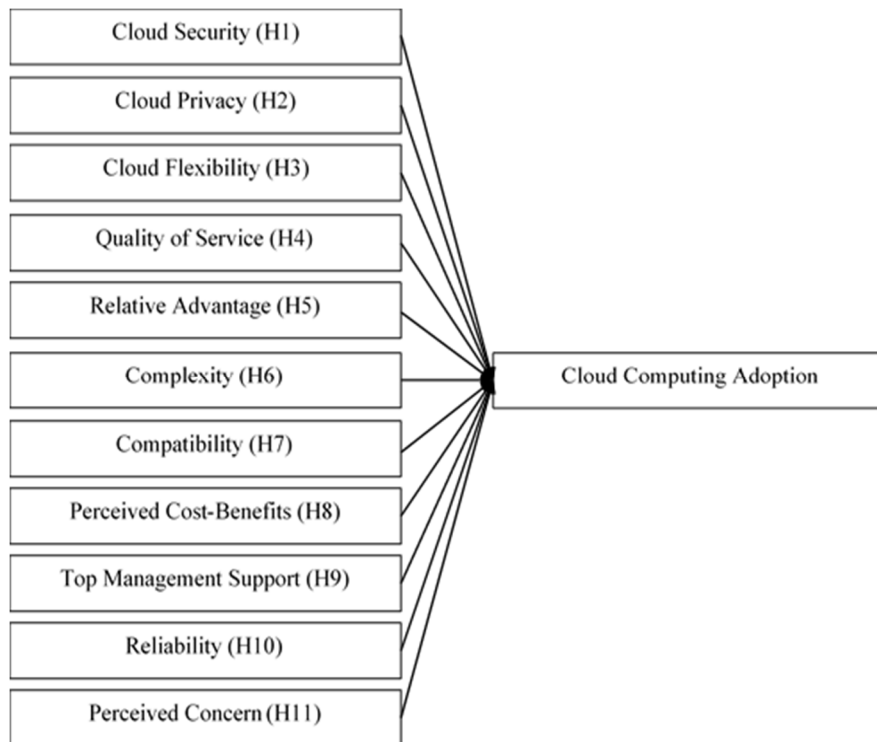

Fig. 1 Research Framework

**B. Method**

The first step is to test the questionnaire's validity and reliability, which collect data from 30 respondents; all item was valid and reliable. Primary data collection is using questionnaires through Google Form. The questionnaire is divided into the respondent profile, and another part is the determinants of cloud computing adoption (cloud security, cloud privacy, quality of service, relative advantage, complexity, compatibility, perceived cost-benefit, top

management support, reliability, & perceived concern). This questionnaire measures the item using five Likert scales.

**III. RESULTS AND DISCUSSION**

**A. Results**

Table 1 shows the demographic of the respondents. Most respondents with age more than 50 years old, position as purchasing/sales/warehouse manager, with company age between 5 until 10 years.

TABLE I  
DEMOGRAPHIC PROFILE

Demographic	Item	Frequency	%
Age	< 25	51	40.8
	25-50	10	8.0
	> 50	64	51.2
Role in the company	Staff	55	44.0
	Supervisor	11	8.8
	Manager	12	9.6
	CEO/Director	29	23.2
	Others	18	14.4
Position in the company	Purchase/Sale/Warehouse	68	54.4
	HRD/Legal/General	13	10.4
	Accounting/Finance	23	18.4
	IT	18	14.4
	Others	3	2.4
Total employees in the company	<=19	61	48.8
	20-99	64	51.2
	< 5	37	29.6
Company age	5-10	57	45.6
	> 10	31	24.8
	Service	35	28.0
Type of company	Trading	11	8.8
	Manufacturing	32	25.6
	Mixed	47	37.6

Demographic facts of respondents (n=125)

To prove that the result is reliable and valid, there is a need to establish convergent validity. The cut-off value for loadings is 0.5 and the Average Variance Extracted (AVE) also is 0.5 and above. The Composite Reliability (CR) should be 0.7 and above, while the  $f^2$  minimum effect is 0.002, and the most prominent effect should be 0.35. The predictive relevance ( $Q^2$ ) should be more than zero to establish that the result accurately predicts the targeted variable. All of the cut-off value is following the guideline by [25]. In Table 2 and Figure 2, all value meets the cut-off value except for  $f^2$  for cloud computing, cloud complexity, cloud perceived concern, cloud reliability, relative cloud advantage, perceived cost-benefit, and cloud security. To decide that those variables do not affect cloud computing adoption, there is a need to investigate the hypothesis in Table 3. If the hypothesis is accepted, then the result with lower or insignificant  $f^2$  means that it has a lower effect on the dependent variable and does not mean it is insignificant. The  $R^2$  shows that all eleven variables can explain 58 percent of cloud computing adoption, which is a satisfactory result.

TABLE II  
CONVERGENT VALIDITY

Variable	Items	Loadings	CR	AVE	$f^2$	$R^2$	$Q^2$
Cloud Computing Adoption	CCA	1	1	1		0.585	
Cloud Compatibility	CCp1	0.814	0.831	0.711	0.002		0.170
	CCp2	0.872					
Cloud Complexity	CCx1	0.735	0.826	0.614	0.014		0.246
	CCx2	0.845					
	CCx3	0.768					
Cloud Flexibility	CF1	0.894	0.885	0.793	0.035		0.346
	CF2	0.887					
Cloud Privacy	CP1	0.755	0.857	0.667	0.027		0.338
	CP2	0.838					
	CP3	0.854					
Cloud Perceived Concern	CPC1	0.890	0.831	0.712	0.020		0.172
	CPC2	0.795					
Cloud Reliability	CR1	0.837	0.852	0.743	0.014		0.235
	CR2	0.885					
Cloud Relative Advantage	CRA1	0.810	0.768	0.623	0.003		0.113
	CRA2	0.768					
Perceived Cost-Benefit	PCB1	0.786	0.820	0.696	0.018		0.133
	PCB2	0.880					
Quality of Service	QoS1	0.774	0.845	0.577	0.036		0.301
	QoS2	0.813					
	QoS3	0.724					
	QoS4	0.724					
Top Management Support	TMS1	0.896	0.899	0.817	0.041		0.400
	TMS2	0.912					
Cloud Security	CS1	0.851	0.826	0.704	0.005		0.145
	CS2	0.827					

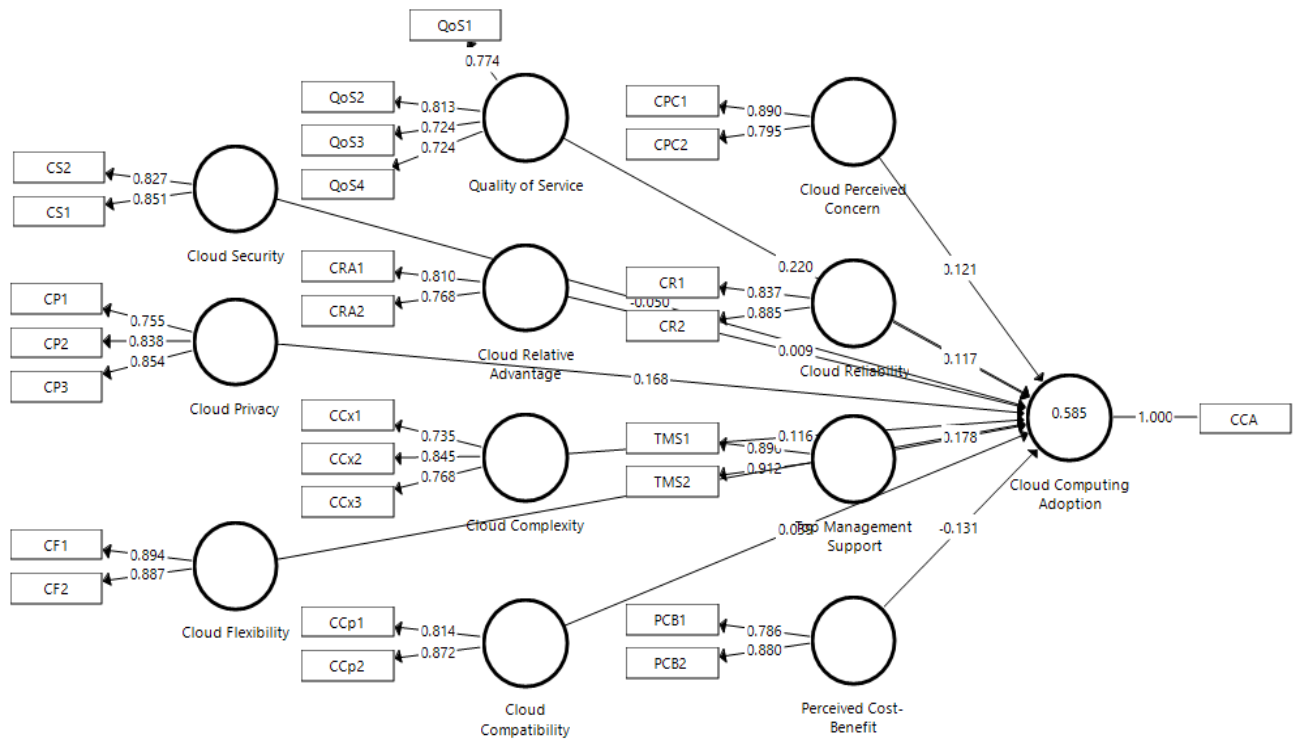

Fig. 2 Convergent validity based on SmartPLS.

TABLE III  
DISCRIMINANT VALIDITY

	1	2	3	4	5	6	7	8	9	10	11	12
1.CCp	0.83											
2.CCx	0.69	0.64										
3.CCA	0.77	0.71	0.74									
4.CF	0.59	0.60	0.68	0.68								
5.CPC	0.87	0.73	0.67	0.80	0.74							
6.CP	0.80	0.78	0.73	0.81	0.62	0.86						
7.CRA	0.84	0.65	0.67	0.79	0.78	0.79	0.83					
8.CR	0.86	0.86	0.69	0.83	0.84	0.85	0.89	0.86				
9.CS	0.87	0.77	0.57	0.69	0.64	0.86	0.80	0.85	0.84			
10.PCB	0.88	0.82	0.74	0.82	0.71	0.77	0.80	0.70	0.84	0.84		
11.QoS	0.70	0.39	0.58	0.58	0.75	0.54	0.45	0.76	0.69	0.75	0.53	
12.TMS												

Table 3 shows the discriminant validity based on Heterotrait-Monotrait ratio (HTMT). The proposed cut-off value is 0.9 to show that the respondents can differentiate each

variable when identifying the variable based on the survey [24]. The result shows that discriminant validity is established.

TABLE IV  
HYPOTHESIS TESTING

Path	Beta	Std Error	t-value	p-value	Decision
CCp -> CCA		0.039	0.083	0.462	0.322 <b>Reject</b>
CCx -> CCA		0.116	0.083	1.389	0.083 <b>Reject</b>
CF -> CCA		0.189	0.081	2.323	0.010 <b>Accept</b>
CPC -> CCA		0.121	0.071	1.716	0.043 <b>Accept</b>
CP -> CCA		0.168	0.094	1.796	0.037 <b>Accept</b>
CRA -> CCA		0.179	0.096	2.095	0.002 <b>Accept</b>
CR -> CCA		0.117	0.101	1.163	0.123 <b>Reject</b>
CS -> CCA		0.050	0.101	0.495	0.310 <b>Reject</b>
PCB -> CCA		0.121	0.089	1.674	0.001 <b>Accept</b>
QoS -> CCA		0.220	0.104	2.11	0.018 <b>Accept</b>
TMS -> CCA		0.178	0.074	2.39	0.009 <b>Accept</b>

Table 4 shows that there are seven hypotheses accepted and four hypotheses rejected. The cut-off value to decide whether to accept or reject the hypothesis is based on t-value and p-value. The proposed t-value cut-off point is 1.645 for one-tailed and 0.05 for p-value [25].

### B. Discussion

The objective of this research is to investigate cloud computing adoption drivers. The findings show that all of the investigated drivers were significant to the Indonesia SMEs managers. The finding suggests that the creative industry has already made aware of cloud computing's benefits and importance. In that regard, companies are moving toward the adoption of cloud computing in their entire business process and supply chain network.

The demographic profile has shown that SMEs in Indonesia is ready for Industry Revolution 4.0. Future research should look into the policies and incentives provided by the industry and the Indonesian government. Investigation of micro, small-medium enterprises, medium-sized, and large companies are also recommended to get the bigger picture of cloud computing adoption in the industry.

This research has laid the groundwork for the understanding of technology acceptance in companies. As shown in the result, the hypotheses were geared for the operations of the company. The result has contributed empirically to the literature because companies adopted technology to improve their efficiency and operational excellence. On the other hand, future research should focus on the environmental and social aspects of cloud computing adoption to contribute to sustainable development goals.

The finding proved that SMEs can compete with larger companies, and technology adoption, such as cloud computing, is not hampering their competitive edge. However, the Indonesian government, policymakers and scholars especially should look into the integration of SMEs in the more massive companies' supply chain. The integration will result in better adoption of Industry Revolution 4.0 technology and improvement in business performance.

This research limitation lies in the data collection timeline. The data was collected during the pandemic Covid-19. Thus, getting a higher response rate from the population is not possible. Future research should look into other types of businesses and industries to further enhance the theory, literature, and policy. Lastly, the research has underlined 11 drivers of cloud computing from the managerial perspective. To understand SMEs' readiness, the future unit of analysis should include technicians, engineers, or IT experts.

### IV. CONCLUSION

This research suggested 11 cloud adoption variables. Only seven hypotheses have been accepted. Such as cloud flexibility, cloud perceived concern, cloud privacy, relative cloud advantage, perceived cost-benefit, quality of service, and top management support. The result shows that small and medium-sized enterprises in Indonesia are conscious of cloud computing. Besides, SMEs are strategizing for the incorporation of their activities of cloud computing. This research contributes to the empirical findings of cloud adoption in small and medium-sized enterprises and Indonesia. Also, this study allows policymakers to direct

benefits and strategies that can be changed or created for Industry Revolution 4.0 readiness. For businesses that do not have cloud infrastructure, it will be a pillar to see if the company can compete on the level ground with companies that have already implemented cloud computing.

### ACKNOWLEDGMENT

Research and Technology Transfer Office supports this work, Bina Nusantara University, as a part of Bina Nusantara University's International Research Grant entitled Application of Cloud Computing Management Systems for Creative Industries: Studies on Micro and Small Enterprises in Indonesia with contract number: No.026/VR.RTT/IV/2020 and contract date: 6 April 2020.

### REFERENCES

- [1] UNCTAD (2019). Global creative economy shows resilience, growth. Switzerland: United Nations Conference on Trade and Development.
- [2] Jakarta Post (2017). Bekraf develops conducive creative economy ecosystem. Retrieved from <https://www.thejakartapost.com/adv-longform/2017/11/10/bekraf-develops-conducive-creative-economy-ecosystem.html>
- [3] Shaharudin, M. S., Fernando, Y., Chiappetta Jabbour, C. J., Sroufe, R., & Jasmi, M. F. A. (2019). Past, present, and future low carbon supply chain management: A content review using social network analysis. *Journal of Cleaner Production*, 218, 629–643.
- [4] Fernando, Y., Elias, F., Shaharudin, M. S., & Rajan, J. (2019). Transforming Food Waste into Value Added Products: A Circular Economy Analysis of Malaysian Fisheries Sector. *Proceeding of Nano-Micromaterials for Circular Economy and Sustainability in the East Asia Pacific*, 1, 1–13.
- [5] Wang, Z., Wang, N., Su, X., & Ge, S. (2020). An empirical study on business analytics affordances enhancing the management of cloud computing data security. *International Journal of Information Management*, 50, 387-394.
- [6] Namasudra, S., Devi, D., Kadry, S., Sundarasekar, R., & Shanthini, A. (2020). Towards DNA based data security in the cloud computing environment. *Computer Communications*, 151, 539-547.
- [7] Sun, P. J. (2020). Security and privacy protection in cloud computing: Discussions and challenges. *Journal of Network and Computer Applications*, 102642.
- [8] Kocabas, O., & Soyata, T. (2020). Towards privacy-preserving medical cloud computing using homomorphic encryption. In *Virtual and Mobile Healthcare: Breakthroughs in Research and Practice* (pp. 93-125). IGI Global.
- [9] Kayes, A. S. M., Rahayu, W., Watters, P., Alazab, M., Dillon, T., & Chang, E. (2020). Achieving security scalability and flexibility using Fog-Based Context-Aware Access Control. *Future Generation Computer Systems*, 107, 307-323.
- [10] Abada, A., & St-Hilaire, M. (2020, June). Energy Credits Auction Mechanism for Enhancing the Grid's Upward Flexibility Using Datacenters. In *2020 European Conference on Networks and Communications (EuCNC)* (pp. 336-341). IEEE.
- [11] Senarathna, I. R. (2016, February). Cloud Computing Adoption by SMEs in Australia. Retrieved August 14, 2020, from Deakin.edu.au: <http://dro.deakin.edu.au/eserv/DU:30088887/senarathna-cloudcomputing-2016A.pdf>
- [12] Ali, M. B. (2020). Multi-Perspectives of Cloud Computing Service Adoption Quality and Risks in Higher Education. In *Handbook of Research on Modern Educational Technologies, Applications, and Management* (pp. 1-19). IGI Global.
- [13] Yudi Fernando, Shaharudin, M. S., Haron, H., Karim, N. A., Ganesan, Y., Fernando, Y., Shaharudin, M. S., Haron, H., Karim, N. A., & Ganesan, Y. (2018). A Moderating Impact of ISO 14001 Certified Firms on Reverse Logistics Implementation: Analysis of A Second-Order Model. *8th International Borneo Business Conference, Iso 14001*, 31–43.
- [14] Fernando, Y., Jasmi, M. F. A., & Shaharudin, M. S. (2019). Maritime green supply chain management: Its light and shadow on the bottom line dimensions of sustainable business performance. *International Journal of Shipping and Transport Logistics*, 11(1), 60–93.

- [15] Altowaijri, S. M. (2020). An architecture to improve the security of cloud computing in the healthcare sector. In *Smart Infrastructure and Applications* (pp. 249-266). Springer, Cham.
- [16] Fernando, Y., Wah, W. X., & Shaharudin, M. S. (2016). Does a firm's innovation category matter in practising eco-innovation? Evidence from the lens of Malaysia companies practicing green technology. *Journal of Manufacturing Technology Management*, 27(2), 208–233.
- [17] Alzakholi, O., Shukur, H., Zebari, R., Abas, S., & Sadeeq, M. (2020). Comparison Among Cloud Technologies and Cloud Performance. *Journal of Applied Science and Technology Trends*, 1(2), 40-47.
- [18] Pathan, Z. H., Jianqiu, Z., Latif, Z., Memon, S., & Hao, D. (2017). Research on ICT Patterns and Integration in Small & Medium Enterprises" A Case Study of Pakistan. *Human Systems Management*, 197-209.
- [19] El-Haddadeh, R. (2020). Digital innovation dynamics influence on organisational adoption: the case of cloud computing services. *Information Systems Frontiers*, 22(4), 985-999.
- [20] Montes, D., Añel, J. A., Wallom, D. C., Uhe, P., & Pena, T. F. (2020). Cloud Computing for Climate Modelling: Evaluation, Challenges and Benefits. *Computers*, 9(2), 52.
- [21] Kumar, D., Verma, P., & Samalia, H. V. (2017). Exploring suitability of cloud computing for small and medium-sized enterprises in India. *Journal of Small Business and Enterprise Development*.
- [22] Khayer, A., Talukder, M. S., Bao, Y., & Hossain, M. N. (2020). Cloud computing adoption and its impact on SMEs' performance for cloud supported operations: A dual-stage analytical approach. *Technology in Society*, 60, 101225.
- [23] Mesbahi, M. R., Rahmani, A. M., & Hosseinzadeh, M. (2018). Reliability and high availability in cloud computing environments: a reference roadmap. *Human-centric Computing and Information Science*
- [24] Kline, R. B. (2015). *Principles and practice of structural equation modeling*. Guilford publications.
- [25] Hair, J. F. J., Hult, G. T. M., Ringle, C. M., & Sarstedt, M. (2017). *A Primer on Partial Least Squares Structural Equation Modelling (PLS-SEM)* (Second Edn). Sage.