

We are IntechOpen, the world's leading publisher of Open Access books Built by scientists, for scientists

5,000

Open access books available

124,000

International authors and editors

140M

Downloads

Our authors are among the

154

Countries delivered to

TOP 1%

most cited scientists

12.2%

Contributors from top 500 universities



WEB OF SCIENCE™

Selection of our books indexed in the Book Citation Index
in Web of Science™ Core Collection (BKCI)

Interested in publishing with us?
Contact book.department@intechopen.com

Numbers displayed above are based on latest data collected.
For more information visit www.intechopen.com



Various Methods for Removal, Treatment, and Detection of Emerging Water Contaminants

Wan Norfazilah Wan Ismail and Siti Umairah Mokhtar

Abstract

This review covers various methods to remove, treat, and detect emerging contaminants (ECs) in water and wastewater. ECs have drawn the attention of many countries due to their potential threat to human health as well as the environment. They are found in many human everyday products that are continuously released into the environment and will accumulate over time. In order to remove ECs, a number of methods have been developed, which include adsorption, membrane technology, biological treatment, and advanced oxidation process. In addition, advances in detection techniques and instrumentation are now able to detect ECs in which they occur at low concentrations. All the removal, treatment, and detection methods will be covered in this review. The removal, treatment, and detection of ECs and their transformation products in water and wastewater are challenging tasks due to their complexity in water samples. Therefore, such information should be emphasized in order to improve the current methods and develop new advanced methods.

Keywords: emerging contaminants, adsorption, membrane technology, biological treatment, advanced oxidation process, chromatography, spectroscopy

1. Introduction

In recent years, emerging contaminants (ECs) have been of great concern to environmentalists and governmental agencies due to their potential threat to human health as well as the environment. Three main sources of ECs have been identified, which include daily products used by humans, hormones, or medicines used by livestock and pesticides or nanomaterials (to improve the uptake of nutrient) used on plants [1]. They enter the environment in various ways. For example, the daily use products produced by humans will enter the wastewater, which will then be treated in conventional wastewater treatment plant (WWTP) without any ECs removal facility. Treated wastewater and wastewater sludge that still contain ECs will be released back into water sources and used as fertilizer on soil, respectively. ECs from livestock will go into their manure, while ECs on plants will be directly applied on soil from which they are eventually leached out by rain water thereby going all the way into nearby water sources. **Figure 1** summarizes the release of ECs into water from three main sources.

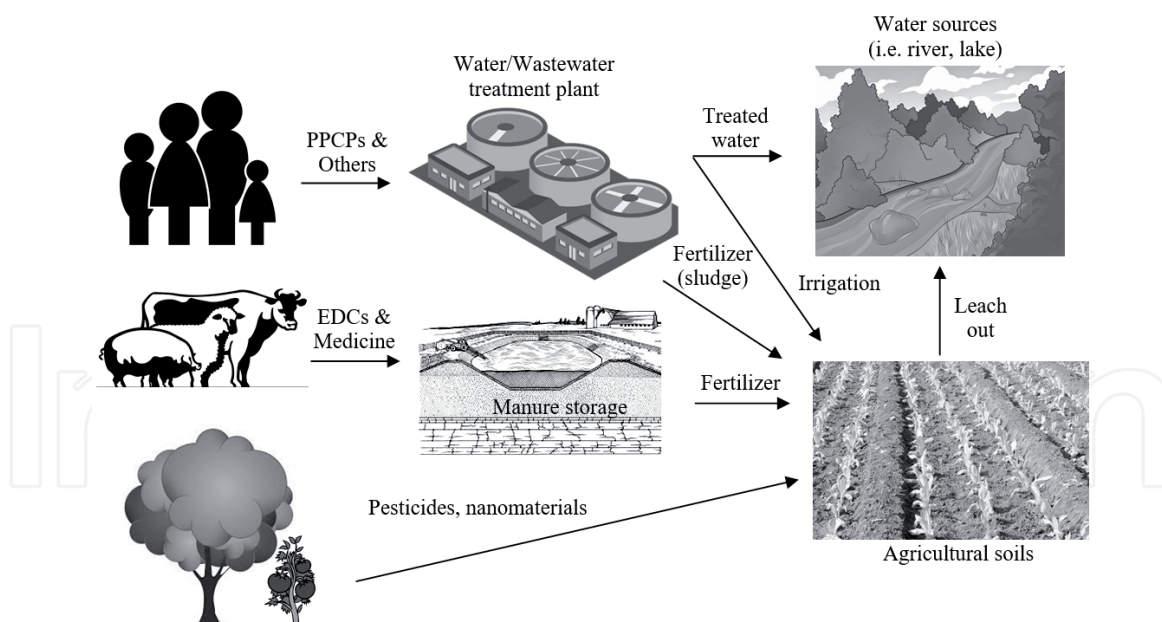

Figure 1.
Sources of ECs and their release to the water sources.

Water consumption in particular potable water increases every year due to population growth, urbanization, industrial development as well as changes in agricultural and land use practices [2]. One of the most serious problems faced by billions of people today is the availability of fresh water. Governments and organizations all over the world have realized that sustainable water and wastewater management are necessary components of functioning communities. However, current situation has shown that different classes of ECs have been identified in waters with low elimination rates [3]. Furthermore, for most of the ECs, it is difficult to predict their circumstances in the aquatic environment due to insufficient data on their occurrence, risk assessment, and ecotoxicological [4]. The reason behind this is partially due to the limitation of analytical methods for low concentrations measurement of ECs (usually part per billion or part per trillion levels), diversity of their chemical properties, and the complexity of matrices [5].

In order to improve the current analytical methods by removing or treating ECs in water and wastewater, a number of methods have been developed and reviewed in this paper, which included adsorption, membrane technology, biological treatment, and advanced oxidation process. Such information should be taken into consideration in order to improve the current methods or develop new advanced methods.

2. Emerging contaminants (ECs)

According to US Geological Survey (2015), ECs are defined as “any synthetic or naturally occurring chemicals or microorganisms that are not commonly monitored in the environment and cause known or suspected adverse ecological and/or human health effects” [6]. Three kinds of target can be generally defined as “ECs” in scientific research, namely (i) new compounds and molecules that recently appeared, (ii) existed contaminants with undiscovered environmental issues or emerging interests, and (iii) new information on their environmental risks that challenges the understanding of some legacy contaminants [7].

Obviously, ECs are found in many of our everyday products, such as human and veterinary pharmaceuticals, personal care products, surfactants and residues of surfactants, plasticizers, and different industrial additives that are continuously

released into the environment and will accumulate over time. Although they bring great convenience and benefits, humans face the risks resulting from their growing applications. Potential carcinogenicity, reproductive dysfunction, and endocrine disrupting influences are some of the major adverse effects on human health associated with ECs. In the 1990s, research started on the hormonal disruption of fish in surface waters. Jobling et al. were the first to document widespread sexual endocrine disruption in wild fish—consistent with exposure to hormonally active substances in the surface waters of Great Britain [8]. Hormones found in surface water mostly came from sewage water and were not removed by treatment [9].

Beyond the health concerns, these substances that are entering the environment inevitably are not only sourced from daily use but also from the field of healthcare, industry, transport, agriculture, and so on [10]. Most of these emerging contaminants are released into the environmental waters mainly due to their incomplete removal in the sewage effluent via the WWTP. The determined concentrations of most emerging contaminants in surface water generally range from under ng/L to thousands of µg/L level [11]. Such low concentrations may sometimes lead to underestimation of their environmental impacts. However, it has been reported that some of these organic compounds showed strong persistence after being released into the environmental waters. Due to the lack of risk assessment for ECs, this is not included in policy and monitoring programs [12]. However, the absence of standard does not imply that a substance is safe.

There are many ECs that act as endocrine disrupting chemicals (EDCs) [13–15] which can disrupt animal reproduction and development at low level exposure by mimicking the naturally occurring hormones that bind to a receptor and block the endogenous hormone, or interfere with the normal hormonal function [16]. EDCs are defined by the World Health Organization (WHO) as chemicals that may alter the reproductive function in males and females, increase incidence of breast cancer, abnormal growth patterns, and neurodevelopmental delays in children as well as changes in immune function [17]. EDCs include natural hormones created in the body or synthetic hormones as well as industrial/commercial compounds which can have some hormonal functions, such as pharmaceuticals and personal care products (PPCPs) [18–20], pesticides [21–23], plasticizers [24, 25], nanoparticles [26, 27], and so on.

Natural estrogen hormones such as estrone, estradiol, and estriol are widely found in wastewater streams that mainly derive from human urines [28]. Human excretes estrogens from the body, even without taking hormonal drugs. As a result, natural hormones are believed to be present in a wide range of concentrations in wastewater from households, which are conveyed to the WWTP through the sewer system. Consequently, the aquatic species in downstream waters will pose elevated dosages of estrogenic compounds. These compounds can cause feminism at certain dosage to the exposed fish [29]. Länge et al. reported that a low concentration of 4 ng/L of ethinylestradiol can block the development of secondary sexual characteristics for male fathead minnows [30].

Pharmaceutically active compounds, namely prescription drugs, over-the-counter therapeutics, and veterinary drugs as well as personal care products, such as microbial disinfectants, represent the major portion of the domestically produced EDCs [31]. The health risks of these contaminants are a real concern in preserving a healthy ecosystem for aquatic life creatures and for water reuse purposes [32]. Even though the concentrations of pharmaceuticals in the aquatic environment are generally reported to be low, these compounds possess a high biological activity so often associated with high stability and their potential impact on the aquatic wildlife even at trace levels [33]. Bisphenol-A (BPA) is one of the most common EDCs found in every house, a monomer for the production of polycarbonate and

epoxy resins found in some plastics that has been linked to heart disease, infertility, and behavioral and developmental problems in children exposed in utero [34].

Furthermore, pesticides are a class of compounds that may produce a wide range of potentially hazardous toxic side effects to the environment despite their benefits. Their extensive past or present use contributes to their prevalence as environmental contaminants in groundwater and surface water [35]. Reemtsma et al. studied the occurrence of 150 pesticides and their metabolites in 58 groundwater and surface water samples. The results revealed that 17 of the 27 highly ranked metabolites were denoted as emerging metabolites. Therefore, they concluded that metabolites could be found more frequently in groundwater than their parent compounds [36]. Besides the use of these compounds as herbicides or pesticides, some synthetic steroid hormones are used as growth promoters in beef cattle. It had shown that the soil and runoff from large feedlots contain a large amount of bioactive steroids that may affect wildlife and the environment around these cattle feeding operations [37]. Consequently, although they are in low concentrations, the elimination of these trace contaminants from entering the water resources is required.

3. Removal or treatment method of ECs

The traditional wastewater treatment process such as activated sludge is designed to remove solids, organic loadings, and pathogens. Although several treatment steps in a wastewater treatment plant can contribute to the partial removal of ECs, complete removal has been proven to be a challenge due to high variety, extreme low concentration, and unique characteristics of ECs [38]. Due to the increased number of trace ECs detected in water and wastewater streams and the fact that EDCs have adverse effects on the human endocrine system, investigation on the removal or treatment of these micro contaminants grabs considerable attention of many researchers worldwide [39].

Adsorption technology, membrane technology, biological treatment, and advanced oxidation method are among various remediation options considered to be effective removal or treatment methods for ECs from wastewater or water sources. The removal and treatment of ECs and their transformation products in water and wastewater are challenging tasks due to their complexity in water samples. Therefore, information on the mentioned treatment methods should be taken into consideration in order to improve the current methods and develop new advanced methods.

3.1 Adsorption technology

Adsorption is a process which involves the mass transfer of substances between two phases, namely liquid-liquid, liquid-solid, gas-liquid, or gas-solid interface [40]. Adsorbents are used to adsorb any particular pollutant (adsorbate) from wastewater with the help of intermolecular forces [41]. There are two types of interaction between the solid surface and adsorbates, namely physisorption and chemisorption. The process is called physisorption if the interaction has a weak physical nature such as van der Waals forces and the process results are reversible [42]. Additionally, it occurs at lower or close to the critical temperature of the adsorbate. Contrary to physisorption, chemisorption involves the chemical bonding between solid surface and adsorbates. In contrast, it occurs only as a monolayer, and adsorbates are hardly removed because of the strong interaction. Both processes can occur simultaneously or alternatively, depending on the circumstances [43]. To study on adsorption method, one should consider the factors that affect the adsorption process, such as (i) surface area, (ii) nature and initial concentration of

adsorbate, (iii) solution pH, (iv) temperature, (v) interfering substances, and (vi) nature and dose of adsorbent [44].

Adsorption is simple and effective, but it requires high operating costs associated with the generation of commercial adsorbents (i.e., activated carbons, minerals, and natural clays) [45]. Various researchers have attempted to prepare alternative adsorbents from agricultural and industrial wastes to replace the commercial adsorbents in order to reduce the costs as well as the environmental effects [46]. Therefore, this review presents the use of unconventional adsorbents, especially agriculture wastes instead of commercial adsorbents. Hemicellulose, starch, lipids, proteins, water, lignin, hydrocarbons, and simple sugars are the basic components of agricultural waste materials that contain a variety of functional groups [47]. Many previous studies have shown that agricultural materials containing cellulose have a high sorption capacity of various pollutants. Their applications as adsorbents can be extended through chemical treatment with numerous chemicals, such as to increase their chelating functional groups [41]. Generally, the adsorption takes place by complexation, ion exchange, and hydrogen bonding [48, 49]. Cheap and readily available resources of agricultural solid wastes such as rice husk and straw [50, 51], coconut husk and coir dust [52, 53], wood sawdust and chips [54, 55], and fruit peels and stones [56–59] have been investigated for the removal of pollutants from aqueous solutions.

Mandal et al. [50] studied on bamboo chips, corn cob, eucalyptus bark, rice husk, and rice straw as low-cost adsorbent for the removal of pesticides, namely atrazine and imidacloprid. The experimental data obtained were modeled with Freundlich and Elovich isotherm equations. The authors tested the effect of contact time, pH, pesticide concentration, and adsorption-desorption behavior of the adsorbents. The authors concluded that the kinetics study for both pesticides on rice straw adsorbent was well represented by the modified Elovich model, with a maximum adsorption capacity of 70.7% (atrazine) and 77.8% (imidacloprid). They also carried out further studies to evaluate the adsorption efficiency of rice straw adsorbent by treating it with phosphoric acid and found that it was able to further enhance the sorption of both pesticides. From the results obtained, the authors suggested that among the five unconventional adsorbents used, rice straw adsorbent has great potential for pesticide industrial waste water treatment.

The removal of heavy metals from wastewater using rice husk as adsorbent was carried out by Hegazi [51] who found that the low-cost adsorbent was able to effectively remove Fe, Pb, and Ni simultaneously within a concentration range of 20–60 mg/L. The author evaluated the effect of adsorbent amount on the removal of the selected heavy metals, and the results showed that the removal percentage increased with the increase of adsorbent amount. The maximum adsorption (76–96%) of heavy metals was achieved at room temperature with the optimum contact time of 2 h and pH range of 6.0–7.0. Another analyte that is removed by rice husk adsorbent is tetracycline, a commonly used personal care and veterinary drug [60]. Moreover, Jing and co-authors have modified the rice husk by methanol to improve the adsorption capacity of tetracycline and reduce the inherent organic compound content in the rice husk. Comparison between the modified rice husks with untreated rice husk adsorbents showed approximately 45.6% enhancement of adsorption capacity in 12 h and 17.2% in equilibrium time. They reported that the main factor responsible for the enhancement of tetracycline adsorption was the change in O-containing groups in the modified adsorbent, which affects π - π electron-donor-acceptor interactions between the adsorbent and tetracycline.

The ability to remove dye using coconut husk and its coir dust as adsorbents was investigated by Bello et al. [53] and Etim et al. [52], respectively. The coconut coir dust is a remaining dust after the extraction of fiber from the coconut husk, which is about 70% of the coconut husk weight. Bello and colleagues used acid-activated

coconut husk for the removal of rhodamine-B (Rh-B) dye, and the effects of different operational parameters were examined, namely initial concentration, contact time, and solution temperatures. Adsorption data were fitted to Langmuir, Freundlich, Dubinin-Radushkevich, and Temkin isotherm models. Langmuir isotherm was found to be the most fitted model with the maximum adsorption capacity of 1666.67 mg/g. The authors indicated that the coconut husk adsorbent has greater affinity for Rh-B dye adsorption due to the increase of pore development via acid activation. Meanwhile, Etim et al. used coconut coir dust to remove methylene blue dye, and the effects of adsorbent amount, pH, and concentration with time were studied. Three isotherm models were tested, namely Langmuir, Freundlich, and Temkin, and adsorption was found to fit well into these models with $R^2 \geq 0.90$. The authors suggested that the increase in adsorption capacity of the dye was due to the chemical interaction of the functional groups on the surface of the adsorbent according to the Fourier transform infrared (FTIR) results obtained.

Studies outlined by Thue et al. on wood chips and wood sawdust have revealed their potential as low-cost adsorbents for phenol [54] and metals [55] removal from aqueous solutions, respectively. Former study has modified the wood chips by mixing them with inorganic components before they were pyrolyzed and treated with hydrochloric acid to produce inorganic:organic ratios of 1.0 and 1.5 (ZnCW-1.0; ZnCW-1.5; FeZnCW-1.0; FeZnCW-1.5). The maximum amounts of phenol adsorbed onto activated carbons at 25°C were 434.2, 667.9, 256.5, and 233.5 mg/g for ZnCW-1.0, ZnCW-1.5, FeZnCW-1.0, and FeZnCW-1.5, respectively. The results indicated that ZnCW-1.0 and ZnCW-1.5 exhibited excellent performance in the treatment of simulated effluents contaminated with mixtures of phenols in a complex medium. On the other hand, the latter study focused on the use of first-row transition metals (Co, Ni, Cu, and Zn) in the preparation of activated carbons from wood biomass via microwave-assisted irradiation. Results showed that the metals were bound successfully in different amounts with surface functional groups of the wood biomass through ion exchange and surface complexation interaction during the impregnation step. An adsorption experiment revealed that samples prepared using $ZnCl_2$ showed the highest sorption capacities for the tested adsorbates, followed by $CuCl_2$, $CoCl_2$, and $NiCl_2$.

Three different fruit peels, such as orange, pomelo, and passion fruit peels have been used by Nhung et al. to develop unconventional adsorbents to remove Rh-B from aqueous solution [56]. Equilibrium isotherms were determined and analyzed using the Freundlich equation. Capacities of adsorbent were found to be in the order of passion fruit peels > orange peels > pomelo peels for Rh-B. Other than that, orange peel as an adsorbent has also been studied by Foo and Hameed [57] for the removal of methylene blue. The authors investigated the effects of initial dye concentration (50, 100, 200, 300, 400, and 500 mg/L) and pH (2–12) at room temperature with the contact time of 48 h and adsorbent dosage of 0.20 g. The adsorption capacity of methylene blue was found to be 382.75 mg/g at the initial pH 6.33. In addition, Ben-Ali et al. [58] studied the removal of copper ions onto untreated pomegranate peel in order to explore its potential use as low-cost adsorbents from an agricultural waste. Adsorption isotherms were determined at 313 K, and the experimental data obtained were modeled with the Langmuir, Freundlich, Dubinin-Radushkevich, and Temkin isotherm models. The authors concluded that the equilibrium data were well represented by the Langmuir isotherm equation with the maximum adsorption capacity of 30.12 mg/g.

Torrellas et al. [59] used activated carbons from peach stones as adsorbent for the removal of caffeine (stimulant), diclofenac (anti-inflammatory drug), and carbamazepine (psychiatric drug) from aqueous solution and reported that the adsorption capacity of carbamazepine was higher than caffeine and diclofenac,

reaching to 335 mg/g. The modified adsorbents exhibited an increase in adsorption capacity for carbamazepine due to the existence of hydrophobic character and water solubility properties. Oxidation of the activated carbon had greatly enhanced the hydrophilic character of the material, thereby decreased the adsorption capacity and highly affected the breakthrough times and adsorption capacity values in the fixed-bed adsorption process. The same adsorbent was used to remove dye (methylene blue) [61] and metal (platinum) [62].

The economical and readily available adsorbent would certainly make an adsorption-based process, a viable alternative for the treatment of wastewater that contains pollutants. Depending upon the adsorbent and adsorbate characteristics, the selection of an appropriate adsorbent is the most crucial part to ensure a maximum removal of different types of pollutant. Various environmental conditions and variables are used to ensure the effectiveness of adsorption process, such as initial adsorbate and adsorbent concentration, particle size of adsorbent, temperature, pH, selectivity, ionic strength, contact time, and the rate of rotation. A summary of various agricultural wastes as sources of adsorbents for the removal of various types of ECs is summarized in **Table 1**.

3.2 Membrane technology

Membrane technology is one of the promising technologies for the excellent removal of micropollutants in water. This technology uses both biological (membrane bioreactors) and nonbiological processes (reversed osmosis, ultrafiltration, and nanofiltration). Membrane bioreactors (MBRs) are the combination of membrane-based filtration processes, such as microfiltration (MF) or ultrafiltration (UF) system with suspended growth biological reactors. MBRs are the most prominent and proven processes these days to achieve a relatively clean water from wastewater through the combination of membrane and biological treatments [63, 64].

Agricultural waste	Emerging contaminants	References
Bamboo chips, corn cob, eucalyptus bark, rice husk, and rice straw	Pesticides (atrazine and imidacloprid)	[50]
Rice husk	Metal ions (Fe, Pb and Ni)	[51]
Coconut coir dust	Dye (methylene blue)	[52]
Coconut husk	Dye (Rhodamine-B)	[53]
Wood chips	Phenol	[54]
Wood sawdust	Metal ions (Co, Ni, Cu, and Zn)	[55]
Orange, pomelo, and passion fruit peels	Dye (Rhodamine-B)	[56]
Orange peel	Dye (methylene blue)	[57]
Pomegranate peel	Metal ion (Copper)	[58]
Peach stones	Stimulant (caffeine), anti-inflammatory drug (diclofenac) and psychiatric drug (carbamazepine)	[59]
Rice husk	Personal care and veterinary drug (tetracycline)	[60]
Peach stones	Dye (methylene blue)	[61]
Peach stones	Metal ion (Platinum)	[62]

Table 1.
 Summary of various agricultural wastes as sources of adsorbents for the removal of diverse types of ECs.

Nonbiological processes or pressure-driven membrane technology known as reverse osmosis (RO), nanofiltration (NF), MF, or UF utilizes high pressures across the membranes to accomplish the filtration of contaminants from the produced water [65]. These technologies are the most common membrane techniques of water purification. The membranes are also continuously upgraded or modified for further improvement in performance and usage. Consequently, membrane processes are ideal for removing turbidity and microbiological contaminants. However, high-operation costs still limit its full-scale usage. Membranes easily suffer from fouling problems that could result in unexpected interruptions during the treatment of aqueous contaminants [66].

In Keucken et al. report published in 2017, it proved that using UF can achieve a stable operation even in difficult circumstances and excellent effluent water quality can be achieved as well [67]. Cui and Choo concluded that although fouling cannot be prevented since there must be natural organic matter (NOM) existed in water, it can still be minimized [68]. Potential of hydrogen (pH), ionic strength, and calcium ion concentration are parameters that need to be considered to affect membrane filtration process. Sun et al. conducted experiments to measure the fouling potential when the membrane system is maintained at different values of pH, ionic strength, and calcium ion concentration. They discovered that the fouling potential increased with the increase of the feed solution acidity, ionic strength, and calcium ion concentration [69]. Martin et al. and Bu et al. conducted UF experiments with powdered activated carbon (PAC) adsorption and coagulation as a pretreatment to improve removal efficiency, which provided good examples [70, 71]. The advantage of combining UF with PAC is mainly in terms of the adsorption capacity of PAC and retaining ability of membrane.

In a pilot scale membrane treatment system, Wang et al. compared the removal efficiency of MBR system with integrated membrane systems (MBR/RO or MBR-NF) toward 27 PPCPs. The results suggested that the integrated membrane systems can achieve even higher removal rates of above 95% for most of them. Further studies showed that MBR-RO achieved even better results with the removal of 20 compounds to below detection limits as compared to 13 compounds by MBR/NF [72]. A study conducted by Baransi-Karkaby et al. reported the improved rejection of multiple EDCs and pharmaceutically active compounds (PhACs) by RO membrane elements using concentration polarization- and surfactant-enhanced surface polymerization [73]. The researchers performed experiments using RO membranes modified by grafting poly(glycidyl methacrylate) and as compared to commercial brackish water RO membranes. One of the conclusions was that the modified membrane generally exhibited enhanced rejection comparable with the commercial membrane. However, both membranes did not exhibit a complete rejection for the tested compounds.

3.3 Biological treatment

Many studies have shown that the major removal of ECs is by biodegradation and adsorption during biological treatment (secondary treatment). Therefore, this section will focus on the circumstances and behavior of ECs during the biological treatment processes, which usually consist of two main kinds of treatment, namely activated sludge process (ASP) and trickling filter (TF). The presence of aerobic bacteria and other microorganisms is one of the features of this process in order to oxidize or incorporate into cells of organic matter. The bacteria need a sufficient amount of oxygen in order for the treatment to occur [74]. TF contains fixed surface with a large population of microorganisms, while ASP is where large population of microorganisms combine with wastewater. Normally, after going through TF or ASP, the dense microbial biomass is separated from water by secondary sedimentation [75].

The most common and widely used ASP is to treat both industrial and domestic wastewater. The general process of activated sludge system involves the injection of air into the reactor and continuous re-circulation of biomass into the aeration tank. There are three main divisions in an activated sludge system [76], namely (i) reactor (to keep the microorganisms in suspension and aerators that are used for treatment purposes), (ii) separator system or (allow solids to sediment in sedimentation tank), and (iii) recycle system (solids from sedimentation tank are moved to the aeration tank) (**Figure 2**).

Depending on the type of ASP, there are many benefits as well as drawbacks from using it. Reduced level of ammonia, small space usage, and odor free are a few benefits of some types of ASP. However, a high energy is required to operate aeration tank, and the changes of the effluent characteristics are very rigid [77]. Some examples of factors that affect ASP are the availability of oxygen, temperature, features of the treated wastewater, detergents that produce foam, and return rate [78]. The performance of ASP to remove steroid estrogens in WWTPs was better (up to 100%) than that of the trickling filter (up to 75%) [79]. Han et al. investigated the total removal of organic pollutants in eight full-scale municipal WWTPs by three modified ASP, namely anoxic/oxic (A/O), anaerobic/anoxic/oxic (A²/O), and oxidation ditch process [80]. From the results obtained, it was concluded that the oxidation ditch process appeared to have the advantage of removing tyrosine-like substances and presented a slightly better removal efficiency of tryptophan-like fluorescent substances than the A/O and A²/O processes.

On the other hand, microbial biomass grows on an inert or solid medium in film form with continuous wastewater being sprinkled over them, known as ultrafiltration (fixed film or attached growth systems) [81]. Nowadays, the treatment capacity of the conventional TF has been enhanced with the use of plastic packing as the packing material to replace circular rock. A lot of benefits have been highlighted on this type of biological treatment, including better sludge thickening, low maintenance cost, less energy consumption, and ease of operation. However, the TF system has poor effluent quality as compared to suspended growth systems [82]. The effluent quality of TF is based on the biochemical oxygen demand (BOD) and suspended solids (SS). Temperature, retention time, type of media and its depth, and hydraulic and organic matter are some parameters that might affect the TF performance [83] which lead to a relative removal efficiency difference of some

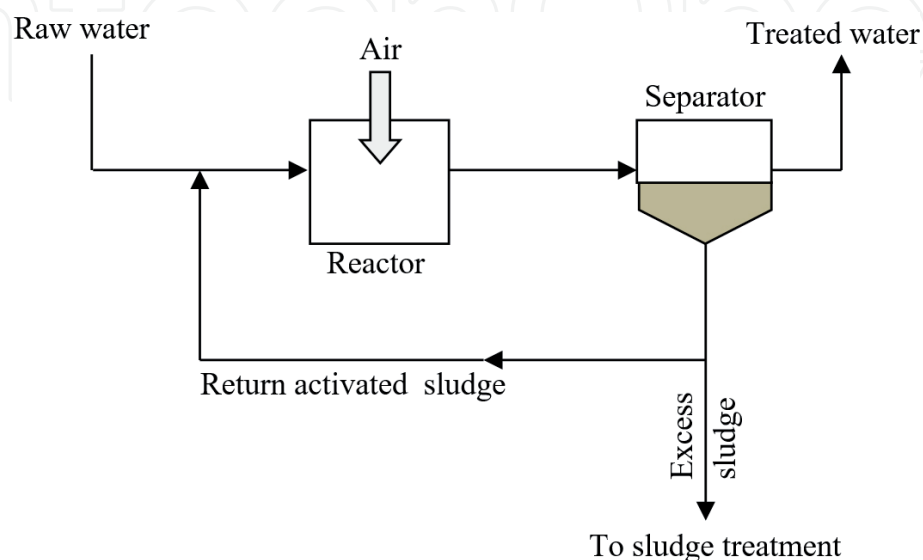

Figure 2.
Diagram of activated sludge process.

ECs, like estrogens in TF [28]. The removal efficiency of 18 different ECs from 42 WWTPs in five different regions of India was studied using different treatment solutions, including TF by Visanji et al. [84]. The results of using TF showed that this treatment is able to remove ofloxacin, dichlofenac, and ibuprofen but unable to remove ampicillin, ciprofloxacin, and naproxen. The authors concluded that although ECs classed under the same category have similar physical, chemical, and biological parameters, these contaminants are not always removed in the same way.

3.4 Advanced oxidation method

Advanced oxidation method (i.e., ozone, O_3/H_2O_2 , H_2O_2/UV , Fenton, ultrasound, photocatalytic, and electrochemical oxidation) can achieve effective degradation of EDCs. Highly reactive oxidant species, such as hydroxyl radical, ion superoxide, hydroperoxyl radical, and organic peroxide radical can highly react with a wide range of organic compounds in a nonselective oxidation way [85]. The target compounds could be quickly and efficiently converted into small inorganic molecules, such as CO_2 and H_2O . Among the advanced oxidation methods used to remove or reduce the concentrations of some hormones and PPCPs from wastewater, ozone oxidation is the most promising technique [86–92]. In secondary effluents, ozonation was found to be very useful in decreasing the concentrations of bisphenol-A, estriol, and 17- β estradiol and their estrogenicity [92, 93]. In addition, the high removal efficiency of estrogens has been observed at low pH by Cesaro and Belgiorno [93]; however, it was impractical to change the sewage pH.

A study by Sun et al. [94] reported that ozone could completely oxidize three estrogens, namely estrone, 17- β estradiol, and 17- α ethinylestradiol in wastewater samples at the dose of 0.3 mg/L. Similar results were achieved by Si et al. [95], showing that combined process of 5.5 mg/L ozone and UF could completely remove the estrogens, with ultraviolet absorbance reduction enhanced from 11–18% or 24–26% as compared to the UF or ozonation alone. Another study by Li et al. [96] found that the application of 1.0–5.0 mg/L ozone was able to decrease the concentration of antibiotics and EDCs to below the limit of detection (LOD). However, other compounds like nitrite and carbonyl compounds as by-products were still detected with a similar level of ozone dosage. In order to remove the by-products, the authors have combined the ozone oxidation process with biological aerated filtration.

The ozone dose applied was found to affect the removal efficiency of some PPCPs. Apart from ozone dose, the reaction time was also found to be one of the main factors to remove ECs, as can be seen in the study conducted by Paucar et al. to remove 38 PPCPs [97]. Among the 38 PPCPs detected in the secondary effluent, 31 PPCPs were degraded to or below their LOD at the ozone dosage of 6 mg/L in 10 min. Of these, eight PPCPs, including dipyridamole, diclofenac, mefenamic acid, diltiazem, ciprofloxacin, chloramphenicol, naproxen, and isopropylantipyrine were readily degraded (below LOD) at the ozone dosage of 1 mg/L in 5 min, and seven PPCPs, namely clarithromycin, sulpiride, N,N-diethyl-3-methylbenzamide, ketoprofen, theophylline, azithromycin, and roxithromycin, were undegraded (below LOD) at the ozone dosage of 6 mg/L with the reaction time of 10 min. As a result, it was found that ozone dose, pH, temperature, compounds of interest and wastewater characteristics, and contact time were among the many factors that could affect the performance of ozonation [98].

Advanced oxidation method with low concentration of ECs would result in low reaction rates and efficiencies, while the short lifetime of the oxidants requires the use of large amounts of oxidants to oxidize the trace levels of ECs and thus leading to the increase in operation costs. In addition, this method also generates toxic intermediate or by-products under suboptimum conditions. Unfortunately, the common

disadvantage shared between all advanced oxidation methods is the high operating cost, which has a somewhat limited large-scale application of this otherwise very powerful technology. However, with the advent of higher efficiency UV lamps, visible light catalysts, and improved reactor design, with the help of computational fluid dynamics and energy modeling, both UV and solar-based photocatalysis have great potential for large-scale application [99]. However, further research is still needed in developing new immobilized photocatalysis reactors and improving the performance, immobilization, and illumination in the reactor of the photocatalyst.

4. Detection methods of emerging contaminants

Previous studies reported that the release of emerging chemical or microbial contaminants to the environment had likely occurred for a long time but may not have been recognized until new detection methods were developed [100]. The detection methods of ECs can be performed by using chromatographic and spectroscopic techniques as well as metal analysis. Chromatographic methods are the most common analytical methods for the identification and detection of various compounds in any kind of samples. Nonpolar, thermostable, and volatile ECs, such as flame retardants, filters, and some pesticides are determined by gas chromatography (GC), while non-volatile, polar, and thermolabile ECs are analyzed by liquid chromatography (LC).

4.1 Liquid chromatography

High-performance liquid chromatography (HPLC) or LC is a gold analytical method used to analyze a wide number of ECs that are relatively polar and nonvolatile in various samples, as can be seen in **Table 2**. In many cases, ultra-high-performance liquid chromatography (UHPLC) has been selected instead of conventional HPLC since these LC techniques provide a more efficient stationary phase through the reduction in particle size, which leads to a better resolution and shorter time [101]. UHPLC applies columns with particle size $<1.7 \mu\text{m}$ and almost always carried out in the reversed phase mode mainly using C18 stationary phases [102]. Generally, for the reversed phase separation of ECs acidified water (with small amounts of formic or acetic acid), methanol, or acetonitrile as organic solvents (in some cases also acidified with formic acid or acetic acid) are used as mobile phases. Furthermore, as stated by Díaz-Cruz et al., among the LC modes, reversed phase (RP) with octadecyl C18-bonded or octyl C8-bonded, silica packing is the most commonly used stationary phase for pharmaceutical analysis [103].

LC coupled with mass spectrometry (MS) allows a successful detection with high sensibility and selectivity of extremely polar, thermally unstable, and large molecular weight compounds [100]. Although MS has been used for quantifying compounds or residues in the environment, MS/MS detection is preferred due to high analytical sensitivity and selectivity in complex matrices. Generally, MS/MS method is based on monitoring selected MS/MS transitions (precursor-product) of the compounds of interest [104]. This approach is known as the most sensitive and rugged for the quantitation purposes of environmental samples at trace levels. In fact, MS/MS showed excellent specificity, but the instrument eliminates the matrix background, which could not be visualized [105]. However, this method is blind to other untargeted species, and thus, the untargeted analysis of unexpected compounds is not feasible.

As an alternative to MS/MS, the use of high-resolution mass spectrometers (LC-HRMS) enables the acquisition of a theoretically unlimited number of species by means of accurate mass measurements in full-scan mode. This allows obtaining the elemental composition of acquired ions which is useful for the identification

Methods	Extraction methods	Instrumental analysis	Emerging contaminants	Samples	References
LC	HFLPME	LC-MS/MS	Pesticides, pharmaceutical product, PCPs, Industrial products, lifestyle products	Water samples	[125]
	SPE	LC-QTOF/MS	Endocrine active compounds	Lakewater	[126]
	SPE	LC-TOFMS	Pharmaceuticals, lifestyle products, drug of abuse, pesticides, nitrosamines, flame retardants, plasticizers, perfluorinated compounds	Surface water and wastewater	[108]
	SPE	LC-Orbitrap-MS	Pharmaceuticals	Wastewater	[127]
	MAE	UHPLC-MS/MS	PCPs, pharmaceuticals and illicit drugs	Crude wastewater, final effluent and river water	[128]
	SPE	UHPLC-Q-Exactive Orbitrap MS	Pesticides, drug residues	Tap water	[107]
	SPE	UHPLC-HRMS	Pharmaceutical, herbicides, stimulant, illicit drugs, preservative agent	Surface water, wastewater, suspended particulate matter, sediments	[129]
	SPE	UHPLC-Q-Orbitrap-MS	Pharmaceutical and personal care products	Wastewater samples	[130]
	MASE	UHPLC-Q-orbitrap	Antibiotics	Aquifer sediments	[106]
	SPE	LC-MS	Drug of abuse, pharmaceuticals	Drinking water	[131]
	Direct injection	UHPLC-QqLIT-MS/MS	Pharmaceuticals, transformation products, pesticides	Treated wastewater	[132]
	SPE	LC-HRMS/MS	Artificial sweeteners, flame retardants, fungicides, herbicides, industrial chemicals, insecticides, pharmaceuticals, plasticizers.	Surface waters	[133]
	SPE	LC-HR MS/MS	Pesticides, veterinary drugs	European rivers and canals	[134]
		LC-QTOFMS	Pesticides, pharmaceuticals	Groundwater and stormwater runoff	[135]
	Soxhlet extraction	UHPLC-QTOFMS	Pharmaceuticals	Freshwater sediments	[136]
	SD-DLLME	LC-MS/MS	Pharmaceuticals, personal care products, pesticides	Water samples	[137]
	SPE	LC-MS/MS	Pharmaceuticals, personal care products	Wastewater samples	[138]

Methods	Extraction methods	Instrumental analysis	Emerging contaminants	Samples	References
GC	QuEChERS	GCxGC-TOFMS	Pesticides, organohalogens	Wastewater samples	[114]
	Rotating-disk sorptive extraction (RSDE)	GC-MS with derivatization	Parabens, hormones, anti-inflammatory drugs, triclosan, bisphenol A	Water samples	[110]
	Disk-based SPE and ultrasound-assisted extraction (UAE)	GC-MS/MS	Polycyclic and nitro-aromatic musks, brominated, chlorinated flame retardants, methyl triclosan, chlorobenzenes, organochlorine pesticides, polychlorinated biphenyls	Seawater	[113]
Metal Analysis	—	SP-ICP-MS	Metal contaminants (Cd)	Wastewater	[139]
	LLE	GC-ICP-MS	Flame retardants	Water samples	[122]
	Online-SPE	HPLC-ICP-MS	Mercury	River and seawater	[123]
	Microwave assisted digestion	ICP-MS	Trace metals	Atmospheric and lake water samples	[118]
	—	ICP-OES	Heavy metals	Soil samples	[140]
	Cross-flow ultrafiltration and LLE	ICP-MS	Colloidal trace metals	Seawater	[120]
	Microwave assisted enzymatic extraction	HPLC/ICP-MS	Heavy metals and organic contaminants	Ground water samples	[141]
Spectroscopic	—	FT-NIR	pharmaceuticals	wastewater	[124]

Table 2. Several studies on the determination of emerging contaminants in water by different techniques for the last 5 years.

of targeted and untargeted compounds, metabolites, or transformation products. In HRMS, mass accuracy is critical for identification purposes. Normally, mass errors of below 5 ppm are observed in routine analysis [101]. Therefore, the use of LC-HRMS for screening contaminants in environmental samples has been extensively reported in literature, such as time-of-flight (TOF), Orbitrap, quadrupole-time-of-flight (Q-TOF), or Q-Orbitrap, as tabulated in **Table 2**.

With the advantage of high resolution, Orbitrap, an ion trap mass analyzer in MS has been used widely for a large number of compounds screening. Referring to hybrid quadrupole Orbitrap mass spectrometry, the qualification and quantification of complicated compounds can be obtained in one analysis [106]. This method is a promising analytical technique, especially as the full scan mode enables the post-target and nontarget analyses of chemical fingerprints which are proven by Cotton et al. [107]. In the study, the screening of a large number of ECs was developed by the combination of SPE and UHPLC-Orbitrap-MS in water samples. As reported by Robles-Molina et al., over 400 ECs have been detected in the analysis of surface water and wastewater, such as pharmaceuticals, lifestyle products, drugs of abuse, pesticides, flame retardants, and plasticizers compounds. The combination of LC with time-of-flight mass spectrometry (TOFMS) has provided a high resolution data from accurate masses of target ions along with retention time data and characteristic insource fragment ions [108].

4.2 Gas chromatography

GC is one of the analytical methods that can be used to separate, analyze, and identify the chemical compounds of any sample. GC coupled with MS is the most common technique and able to produce accurate result. However, GC is less often used than LC to separate ECs because the majority of the studies focused on the determination of very polar contaminants, such as pharmaceuticals and personal care products [100]. Due to the high polarity and low volatility of analytes, such as hydroxyl, phenolic EDCs, amines, and amides, GC method demands the inclusion of a derivatization reaction to improve the chromatographic behavior of the analytes [109]. In fact, derivatizing the ECs into more volatile derivatives is compulsory to enhance detection sensitivity and selectivity as well as improve separation.

Different strategies for derivatization usually involve the use of acylation, alkylation, or silylation reagents. Silylation is the principal derivatization technique in which active hydrogen in the functional groups of ECs is replaced by trimethylsilyl (TMS) which increased the volatility and stability of the compounds. The most common silylation agents are N-methyl-N-(trimethylsilyl) trifluoroacetamide (MSTFA), N,O-bis(trimethylsilyl)-trifluoroacetamide (BSTFA) and N-(t-butyltrimethylsilyl)-N-methyltrifluoroacetamide (MTBSTFA). Based on the study by Arismendi et al., for derivatization method, water sample extract was evaporated under a N₂ stream. A derivatizing agent of N-methyl-N-(trimethylsilyl) trifluoroacetamide (MSTFA) with pyridine was then added and heated at 80°C for 35 min [110] before the derivatized solution was analyzed by using GC-MS.

However, derivatization requires a complicated, tedious procedure, resulting in a number of disadvantages, such as losses and unexpected oxidation of some compounds, less stability of derivatives, and incomplete derivatization and extraction. Although derivatization procedures may be time-consuming and have some limitations, they are still widely used and well established for routine work. In fact, in situ derivatization has been developed as an alternative to avoid preparative steps, accelerate reaction rates, and reduce evaporative losses. This method offers higher chromatographic response, reduction of reagent usage, and less sample preparation time as compared to the manual derivatization. However, the limitation of in situ

derivatization is that a high amount of reagent needs to be injected into the instrument and thus affects the performance of the chromatographic column over time [111].

GC-MS/MS provides a high selectivity and sensitivity as compared to other conventional GC-MS. MS/MS is able to improve the detection by reducing co-extractive compound interferences and sample matrix effects, especially for complex samples [112]. A study by Zhang et al. showed the application of GC-MS/MS in determining the organic pollutants and emerging organic contaminants in seawater samples [113]. It has proven the sensitivity of this method of which the detection limits typically went down to parts per quadrillion (ppq) ranges, while in another study, GC-MS/MS method was developed to determine the ECs, such as personal care, hormones, pharmaceuticals, and organophosphorus flame retardants and plasticizers in various types of vegetables (salads, carrots, lettuce, onions, and tomatoes) [111]. In this study, *in situ* derivatization was carried out in the injection port of the GC system as an alternative to manual procedures because it simplifies the sample preparation and avoids the manipulation of hazardous reagents, and higher chromatographic response can be achieved. The high selectivity of MS/MS detection allowed the identification and quantification of various selected analytes without performing an additional clean-up step [111].

A recent advanced technique namely comprehensive two-dimensional gas chromatography (GC × GC) is a technique that is capable of enhancing the separation of 150–250 relevant compounds with high sensitivity within a complex matrix. It means that many compounds are now completely separated, so there is less need of GC-MS identification/quantitation for routine samples. The two orthogonally aligned columns comprised two different stationary phase chemistries which allow for the increase of peak capacity [114]. Based on Jover et al., three main benefits of GC × GC are (i) increase in chromatographic resolution; (ii) improved analyte detectability due to the cryofocusing that occurs in the thermal modulator, and (iii) chemical ordering in the contour plots [115]. Due to the mentioned benefits, various studies have revealed the application of this technique in various types of samples. In the previous years, GC × GC coupled with TOFMS was applied to determine the numbers of organic contaminants, such as pharmaceuticals, plasticizers personal care products, herbicides, triazines, organophosphorus compounds, pheylureas, organochlorine biocides, polycyclic aromatic hydrocarbons, benzothiazoles, and benzotriazoles in various water samples [114–117].

Prebihalo et al. have reported the identification of some ECs in wastewater and soil samples by using GC × GC-TOFMS. Coupling fast-scanning TOFMS with GC × GC provided the capabilities necessary for the identification of compounds within a complex matrix. In this work, the results showed the presence of halogenated benzotriazoles in wastewater and soil samples. It has also proven that this method is able to decrease the data interpretation time by 50% as compared to traditional methods [114].

4.3 Metal analysis

One of the ECs is heavy metal ions that are gradually being introduced into the environment from various resources. Inductively coupled plasma mass spectrometry (ICP-MS) is the technique of choice for the determination of toxic heavy metal contaminants and nanoparticles in numerous types of samples. The environmental pollution caused by trace metals is a long-term, irreversible process and can be toxic even at low concentrations. ICP-MS is considered as one of the most sensitive techniques for the multi-elemental analysis of trace metals in various elemental samples [118]. The main advantages of this technique lie in the high precision, low economic cost, multi-element, and simultaneous analysis of most elements and isotopes present in the periodic table in a few minutes [100].

ICP-MS also offers extremely low detection limits, ranging from subpart per billion (ppb) to trillion (ppt) for most elements. It has a rapid multi-element scanning capability over a wide range of masses with lower detection limits as compared to graphite furnace-atomic absorption spectroscopy (GF-AAS) and inductively coupled plasma-atomic emission spectroscopy (ICP-AES) [119]. In most cases, the detection limits were 100–1000 times superior than those achieved by ICP-AES. These detection limits were broadly achieved for almost all the elements across the periodic table.

Lu et al. reported an analysis of trace metals, namely Cu, Cd, and Pb in seawater by ICP-MS. The developed method demonstrated a simple, efficient, and convenient analysis with low detection limit (0.13–1.18 pmol/L). The method was successfully applied for the analysis of seawater samples collected from the sites off the south coast North Yellow Sea in Shandong Peninsula, China. In the study, prior to the analysis of the water samples by ICP-MS, the seawater samples were first treated with cross-flow ultrafiltration (CFUF) for the separation of colloidal matter with different molecular weights and was then continued with the liquid-liquid extraction (LLE) procedure. This method was performed to eliminate the possible interference of salt matrix and chloroform during instrumental analysis and concentrate the metals in each sample [120].

In addition, ICP-MS combined with chromatographic techniques is of great importance in the characterization and identification of impurities, degradation products, and speciation studies in pharmaceuticals [121]. It provides valuable information on impurity profiling of drugs and pharmaceuticals. It is becoming the method of choice for quality control and assurance within the pharmaceutical industry. A number of chromatographic techniques, viz., HPLC, capillary electrophoresis (CE), gel permeation chromatography (GPC), ion chromatography (IC), supercritical fluid chromatography (SFC), and GC have been coupled with ICP-MS for the purpose of speciation. A study of GC-ICP-MS was performed for the detection of the six polybrominated diphenyl ether (PBDEs) congeners in environmental water samples [122]. These PBDEs belong to group of brominated flame retardants which are considered as one of the ECs that are added into different industrial products. Apart from that, Jia et al. reported on a simultaneous analysis of mercury speciation in environmental water samples by using HPLC-ICP-MS [123]. HPLC was preferred for the mercury speciation, while ICP-MS is the most used detection technique for elemental analysis. The study revealed a good repeatability and wide linear range achievements of this coupled technique.

4.4 Other techniques

Recently, another technique has been developed to overcome the drawbacks from the traditional techniques, which is Fourier transform near-infrared (FT-NIR) spectroscopy. This technique offers no reagents use, nondestructive character, allowing the reuse of sample after measurement, fast technique, and there is a possibility of online monitoring. Based on Quiñtelas et al. (2018), the combination between FT-NIR and chemometrics was developed to determine pharmaceutical compounds, such as ibuprofen, carbamazepine, β -estradiol, ethinylestradiol, and sulfamethoxazole in wastewaters [124]. A chemometric approach was used by employing a Kolmogorov-Smirnov test to check the normality of the data, a boxplot analysis for outliers' identification and a principal component analysis (PCA) aiming to identify samples interrelationships and define the data sets. Next, a partial least squares (PLS) regression analysis was performed in order to obtain a prediction model that is suitable for pharmaceuticals quantification purposes.

5. Conclusion

Although EC compounds occur in trace concentrations of waters, their adverse effects to aquatic organisms, animals, and humans cannot be underestimated due to their continuous release into the water systems. The removal and detection of ECs and their transformation products in natural and drinking waters are challenging tasks due to the complexity of contaminants in water samples. However, tremendous progress has been made on the assessment of many ECs due to the great efforts and times committed by many scientists working in different research fields. The future trends in the removal of emerging water contaminants will be on the advanced oxidation method because it can effectively degrade the contaminants and has not yet been fully explored. However, it should also be noted that the presence of degradation intermediates can be more toxic than their parent compounds, which remains a great challenge to overcome in advanced oxidation method. In short, feasible techniques need to be in place to remove ECs or at least reduce them below the regulated levels and more research is necessary to completely describe the mechanisms and optimize the main parameters related to the removal of emerging water contaminants in real applications.

Acknowledgements

The authors gratefully acknowledge the grant provided by the Ministry of Education, Malaysia (MOE) under the Fundamental Research Grant Scheme (FRGS) (vote number: RDU1901101) and Universiti Malaysia Pahang (UMP) under the RDU Grant (vote number: RDU1903109).

Declaration of interest statement

The authors certify that they have NO affiliations with or involvement in any organization or entity with any financial or non-financial interests in the subject matter or materials discussed in this manuscript.

Author details

Wan Norfazilah Wan Ismail^{1*} and Siti Umairah Mokhtar²

¹ Faculty of Industrial Sciences and Technology, Universiti Malaysia Pahang, Kuantan, Pahang, Malaysia

² Faculty of Chemical and Process Engineering Technology, Universiti Malaysia Pahang, Kuantan, Pahang, Malaysia

*Address all correspondence to: norfazilah@ump.edu.my

IntechOpen

© 2020 The Author(s). Licensee IntechOpen. This chapter is distributed under the terms of the Creative Commons Attribution License (<http://creativecommons.org/licenses/by/3.0>), which permits unrestricted use, distribution, and reproduction in any medium, provided the original work is properly cited. 

References

- [1] Fawell J, Ong CN. Emerging contaminants and the implications for drinking water. *International Journal of Water Resources Development*. 2012;**28**:247-263
- [2] Falconer IR, Chapman HF, Moore MR, Ranmuthugala G. Endocrine-disrupting compounds: A review of their challenge to sustainable and safe water supply and water reuse. *Environmental Toxicology*. 2006;**21**:181-191
- [3] Petrovic M. Analysis and removal of emerging contaminants in wastewater and drinking water. *TrAC Trends in Analytical Chemistry*. 2003;**22**:685-696
- [4] Huang Q, Bu Q, Zhong W, Shi K, Cao Z, Yu G. Derivation of aquatic predicted no-effect concentration (PNEC) for ibuprofen and sulfamethoxazole based on various toxicity endpoints and the associated risks. *Chemosphere*. 2018;**193**:223-229
- [5] Oetjen K, Giddings CGS, McLaughlin M, Nell M, Blotvogel J, Helbling DE, et al. Emerging analytical methods for the characterization and quantification of organic contaminants in flowback and produced water. *Trends in Environmental Analytical Chemistry*. 2017;**15**:12-23
- [6] Philip JM, Aravind UK, Aravindakumar CT. Emerging contaminants in Indian environmental matrices—A review. *Chemosphere*. 2018;**190**:307-326
- [7] Sauvé S, Desrosiers M. A review of what is an emerging contaminant. *Chemistry Central Journal*. 2014;**8**:15
- [8] Jobling S, Nolan M, Tyler CR, Brighty G, Sumpter JP. Widespread sexual disruption in wild fish. *Environmental Science & Technology*. 1998;**32**:2498-2506
- [9] Mompelat S, Le Bot B, Thomas O. Occurrence and fate of pharmaceutical products and by-products, from resource to drinking water. *Environment International*. 2009;**35**:803-814
- [10] Lei M, Zhang L, Lei J, Zong L, Li J, Wu Z, et al. Overview of emerging contaminants and associated human health effects. *BioMed Research International*. 2015;**2015**:1-12
- [11] Petrie B, Barden R, Kasprzyk-Hordern B. A review on emerging contaminants in wastewaters and the environment: Current knowledge, understudied areas and recommendations for future monitoring. *Water Research*. 2015;**72**:3-27
- [12] Lapworth DJ, Baran N, Stuart ME, Ward RS. Emerging organic contaminants in groundwater: A review of sources, fate and occurrence. *Environmental Pollution*. 2012;**163**:287-303
- [13] Tri TM, Anh DH, Hoai PM, Minh NH, Nam VD, Viet PH, et al. *Emerging Endocrine Disrupting Chemicals and Pharmaceuticals in Vietnam: A Review of Environmental Occurrence and Fate in Aquatic and Indoor Environments*. Washington, DC: American Chemical Society; 2016
- [14] Petrovic M, Eljarrat E, Lopez de Alda MJ, Barceló D. Endocrine disrupting compounds and other emerging contaminants in the environment: A survey on new monitoring strategies and occurrence data. *Analytical and Bioanalytical Chemistry*. 2004;**378**:549-562
- [15] Barceló D, Rodriguez-Mozaz S, Marco M-P, Lopez de Alda M. Biosensors for environmental monitoring of endocrine disruptors: A review article. *Analytical and Bioanalytical Chemistry*. 2004;**378**:588-598

- [16] Schug TT, Janesick A, Blumberg B, Heindel JJ. Endocrine disrupting chemicals and disease susceptibility. *The Journal of Steroid Biochemistry and Molecular Biology*. 2011;127:204-215
- [17] Bergman Å, Heindel JJ, Jobling S, Kidd KA, Zoeller RT. State of the Science of Endocrine Disrupting Chemicals - 2012. United Nations Environment Programme (UNEP) and WHO; 2013
- [18] Ebele AJ, Abou-Elwafa Abdallah M, Harrad S. Pharmaceuticals and personal care products (PPCPs) in the freshwater aquatic environment. *Emerging Contaminants*. 2017;3:1-16
- [19] Liu J-L, Wong M-H. Pharmaceuticals and personal care products (PPCPs): A review on environmental contamination in China. *Environment International*. 2013;59:208-224
- [20] Mottaleb MA, Meziani MJ, Matin MA, Arafat MM, Wahab MA. Emerging Micro-Pollutants Pharmaceuticals and Personal Care Products (PPCPs) Contamination Concerns in Aquatic Organisms - LC/MS and GC/MS Analysis. Washington: American Chemical Society; 2015
- [21] Kairo G, Biron DG, Ben Abdelkader F, Bonnet M, Tchamitchian S, Cousin M, et al. Nosema ceranae, Fipronil and their combination compromise honey bee reproduction via changes in male physiology. *Scientific Reports*. 2017;7:8556
- [22] De Jesús Andino F, Lawrence BP, Robert J. Long term effects of carbaryl exposure on antiviral immune responses in *Xenopus laevis*. *Chemosphere*. 2017;170:169-175
- [23] Ewence A, Brescia S, Johnson I, Rumsby PC. An approach to the identification and regulation of endocrine disrupting pesticides. *Food and Chemical Toxicology*. 2015;78:214-220
- [24] Nagel SC, Bromfield JJ. Bisphenol A: A model endocrine disrupting chemical with a new potential mechanism of action. *Endocrinology*. 2013;154:1962-1964
- [25] Rocha BA, Azevedo LF, Gallimberti M, Campiglia AD, Barbosa F. High levels of bisphenol A and bisphenol S in Brazilian thermal paper receipts and estimation of daily exposure. *Journal of Toxicology and Environmental Health. Part A*. 2015;78:1181-1188
- [26] Ema M, Kobayashi N, Naya M, Hanai S, Nakanishi J. Reproductive and developmental toxicity studies of manufactured nanomaterials. *Reproductive Toxicology*. 2010;30:343-352
- [27] Schilling K, Bradford B, Castelli D, Dufour E, Nash JF, Pape W, et al. Human safety review of 'nano' titanium dioxide and zinc oxide. *Photochemical & Photobiological Sciences*. 2010;9:495-509
- [28] Koh YKK, Chiu TY, Boobis A, Cartmell E, Scrimshaw MD, Lester JN. Treatment and removal strategies for estrogens from wastewater. *Environmental Technology*. 2008;29:245-267
- [29] Vajda AM, Barber LB, Gray JL, Lopez EM, Woodling JD, Norris DO. Reproductive disruption in fish downstream from an estrogenic wastewater effluent. *Environmental Science & Technology*. 2008;42:3407-3414
- [30] Länge R, Hutchinson TH, Croudace CP, Siegmund F, Schweinfurth H, Hampe P, et al. Effects of the synthetic estrogen 17 α -ethinylestradiol on the life-cycle

of the fathead minnow (*Pimephales promelas*). Environmental Toxicology and Chemistry. 2001;20:1216-1227

[31] Maeng SK, Sharma SK, Lekkerkerker-Teunissen K, Amy GL. Occurrence and fate of bulk organic matter and pharmaceutically active compounds in managed aquifer recharge: A review. Water Research. 2011;45:3015-3033

[32] Kashiwada S, Ishikawa H, Miyamoto N, Ohnishi Y, Magara Y. Fish test for endocrine-disruption and estimation of water quality of Japanese rivers. Water Research. 2002;36:2161-2166

[33] Collier AC. Pharmaceutical contaminants in potable water: Potential concerns for pregnant women and children. EcoHealth. 2007;4:164-171

[34] vom Saal FS, Hughes C. An extensive new literature concerning low-dose effects of bisphenol A shows the need for a new risk assessment. Environmental Health Perspectives. 2005;113:926-933

[35] Hayes TB, Collins A, Lee M, Mendoza M, Noriega N, Stuart AA, et al. Hermaphroditic, demasculinized frogs after exposure to the herbicide atrazine at low ecologically relevant doses. Proceedings of the National Academy of Sciences. 2002;99:5476-5480

[36] Reemtsma T, Alder L, Banasiak U. Emerging pesticide metabolites in groundwater and surface water as determined by the application of a multimethod for 150 pesticide metabolites. Water Research. 2013;47:5535-5545

[37] Bartelt-Hunt SL, Snow DD, Kranz WL, Mader TL, Shapiro CA, Donk SJ, et al. Effect of growth Promotants on the occurrence of endogenous and synthetic steroid

hormones on feedlot soils and in runoff from beef cattle feeding operations. Environmental Science & Technology. 2012;46:1352-1360

[38] Ross I, McDonough J, Miles J, Storch P, Kochunarayanan PT, Kalve E, et al. A review of emerging technologies for remediation of PFASs. Remediation Journal. 2018;28:101-126

[39] Archer E, Petrie B, Kasprzyk-Hordern B, Wolfaardt GM. The fate of pharmaceuticals and personal care products (PPCPs), endocrine disrupting contaminants (EDCs), metabolites and illicit drugs in a WWTW and environmental waters. Chemosphere. 2017;174:437-446

[40] Sharma SK. Heavy Metals in Water: Presence, Removal and Safety. Cambridge: Royal Society of Chemistry; 2014

[41] De Gisi S, Lofrano G, Grassi M, Notarnicola M. Characteristics and adsorption capacities of low-cost sorbents for wastewater treatment: A review. Sustainable Materials and Technologies. 2016;9:10-40

[42] Deng F, Luo X-B, Ding L, Luo S-L. Application of Nanomaterials and Nanotechnology in the Reutilization of Metal Ion from Wastewater. Amsterdam: Elsevier; 2019

[43] Tareq R, Akter N, Azam MS. Biochars and Biochar Composites. Amsterdam: Elsevier; 2019

[44] Patel H. Fixed-bed column adsorption study: A comprehensive review. Applied Water Science. 2019;9:45

[45] Uddin MT, Rahman MA, Rukanuzzaman M, Islam MA. A potential low cost adsorbent for the removal of cationic dyes from aqueous solutions. Applied Water Science. 2017;7:2831-2842

- [46] Kyzas G, Kostoglou M. Green adsorbents for wastewaters: A critical review. *Materials*. 2014;**7**:333-364
- [47] Sen TK. *Air, Gas, and Water Pollution Control Using Industrial and Agricultural Solid Wastes Adsorbents*. Boca Raton: CRC Press; 2017
- [48] Fang Y, Zhou A, Yang W, Araya T, Huang Y, Zhao P, et al. Complex formation via hydrogen bonding between rhodamine B and montmorillonite in aqueous solution. *Scientific Reports*. 2018;**8**:229
- [49] Crini G, Lichtfouse E, Wilson LD, Morin-Crini N. *Adsorption-Oriented Processes Using Conventional and Non-conventional Adsorbents for Wastewater Treatment*. Cham: Springer International Publishing; 2018
- [50] Mandal A, Singh N, Purakayastha TJ. Characterization of pesticide sorption behaviour of slow pyrolysis biochars as low cost adsorbent for atrazine and imidacloprid removal. *Science of the Total Environment*. 2017;**577**:376-385
- [51] Hegazi HA. Removal of heavy metals from wastewater using agricultural and industrial wastes as adsorbents. *HBRC Journal*. 2013;**9**:276-282
- [52] Etim UJ, Umoren SA, Eduok UM. Coconut coir dust as a low cost adsorbent for the removal of cationic dye from aqueous solution. *Journal of Saudi Chemical Society*. 2016;**20**:S67-S76
- [53] Bello OS, Adegoke KA, Fagbenro SO, Lameed OS. Functionalized coconut husks for rhodamine-B dye sequestration. *Applied Water Science*. 2019;**9**:8
- [54] Thue PS, Adebayo MA, Lima EC, Sieliechi JM, Machado FM, Dotto GL, et al. Preparation, characterization and application of microwave-assisted activated carbons from wood chips for removal of phenol from aqueous solution. *Journal of Molecular Liquids*. 2016;**223**:1067-1080
- [55] Thue PS, Lima EC, Sieliechi JM, Saucier C, Dias SLP, Vagheti JCP, et al. Effects of first-row transition metals and impregnation ratios on the physicochemical properties of microwave-assisted activated carbons from wood biomass. *Journal of Colloid and Interface Science*. 2017;**486**:163-175
- [56] Nhung NTH, Quynh BTP, Thao PTT, Bich HN, Giang BL. Pretreated fruit peels as adsorbents for removal of dyes from water. *IOP Conference Series Earth and Environmental Sciences*. 2018;**159**:012015
- [57] Foo KY, Hameed BH. Preparation, characterization and evaluation of adsorptive properties of orange peel based activated carbon via microwave induced K₂CO₃ activation. *Bioresource Technology*. 2012;**104**:679-686
- [58] Ben-Ali S, Jaouali I, Souissi-Najar S, Ouederni A. Characterization and adsorption capacity of raw pomegranate peel biosorbent for copper removal. *Journal of Cleaner Production*. 2017;**142**:3809-3821
- [59] Torrellas SÁ, García Lovera R, Escalona N, Sepúlveda C, Sotelo JL, García J. Chemical-activated carbons from peach stones for the adsorption of emerging contaminants in aqueous solutions. *Chemical Engineering Journal*. 2015;**279**:788-798
- [60] Jing X-R, Wang Y-Y, Liu W-J, Wang Y-K, Jiang H. Enhanced adsorption performance of tetracycline in aqueous solutions by methanol-modified biochar. *Chemical Engineering Journal*. 2014;**248**:168-174

- [61] Alvarez-Torrellas S, Garcia-Lovera R, Rodriguez A, Garcia J. Removal of methylene blue by adsorption on mesoporous carbon from peach stones. *Chemical Engineering Transactions*. 2015;**43**:1963-1968
- [62] Martin-Martinez M, Álvarez-Torrellas S, García J, Silva AMT, Faria JL, Gomes HT. Exploring the activity of chemical-activated carbons synthesized from peach stones as metal-free catalysts for wet peroxide oxidation. *Catalysis Today*. 2018;**313**:20-25
- [63] Iorhemen OT, Hamza RA, Tay JH. Membrane bioreactor (MBR) technology for wastewater treatment and reclamation: Membrane fouling. *Membranes*. 2016;**6**:33
- [64] Nofiana R, Istirokhatun T, Susanto H. Reuse of domestic wastewater by membrane technologies towards sustainable city development. *IOP Conference Series Earth and Environmental Sciences*. 2019;**248**:012053
- [65] Abdel-Fatah MA. Nanofiltration systems and applications in wastewater treatment: Review article. *Ain Shams Engineering Journal*. 2018;**9**:3077-3092
- [66] Maddah HA, Alzhrani AS, Bassyouni M, Abdel-Aziz MH, Zoromba M, Almalki AM. Evaluation of various membrane filtration modules for the treatment of seawater. *Applied Water Science*. 2018;**8**:6
- [67] Keucken A, Heinicke G, Persson K, Köhler S. Combined coagulation and ultrafiltration process to counteract increasing NOM in brown surface water. *Watermark*. 2017;**9**:697
- [68] Cui X, Choo K-H. Natural organic matter removal and fouling control in low-pressure membrane filtration for water treatment. *Environmental Engineering Research*. 2014;**19**:1-8
- [69] Sun C, Zhang N, Li F, Ke G, Song L, Liu X, et al. Quantitative analysis of membrane fouling mechanisms involved in microfiltration of humic acid–protein mixtures at different solution conditions. *Watermark*. 2018;**10**:1306
- [70] Schulz M, Bünting S, Ernst M. Impact of powdered activated carbon structural properties on removal of organic foulants in combined adsorption-ultrafiltration. *Watermark*. 2017;**9**:580
- [71] Bu F, Gao B, Yue Q, Liu C, Wang W, Shen X. The combination of coagulation and adsorption for controlling ultrafiltration membrane fouling in water treatment. *Watermark*. 2019;**11**:90
- [72] Wang Y, Wang X, Li M, Dong J, Sun C, Chen G. Removal of pharmaceutical and personal care products (PPCPs) from municipal waste water with integrated membrane systems, MBR-RO/NF. *International Journal of Environmental Research and Public Health*. 2018;**15**:269
- [73] Baransi-Karkaby K, Bass M, Freger V. In situ modification of reverse osmosis membrane elements for enhanced removal of multiple micropollutants. *Membranes*. 2019;**9**:28
- [74] Akhbari A, Kutty PK, Chuen OC, Ibrahim S. A study of palm oil mill processing and environmental assessment of palm oil mill effluent treatment. *Environmental Engineering Research*. 2019;**25**:212-221
- [75] Conserva S, Tatti F, Torretta V, Ferronato N, Viotti P. An integrated approach to the biological reactor–sedimentation tank system. *Resources*. 2019;**8**:94
- [76] Samer M. *Biological and Chemical Wastewater Treatment Processes*. London: IntechOpen; 2015

- [77] Drewnowski J, Remiszewska-Skwarek A, Duda S, Łagód G. Aeration process in bioreactors as the Main energy consumer in a wastewater treatment plant. Review of solutions and methods of process optimization. *Processes*. 2019;7:311
- [78] Kolev S, A. Dairy wastewaters—General characteristics and treatment possibilities—A review. *Food Technology and Biotechnology*. 2017;55:14-28
- [79] Ting YF, Praveena SM. Sources, mechanisms, and fate of steroid estrogens in wastewater treatment plants: A mini review. *Environmental Monitoring and Assessment*. 2017;189:178
- [80] Han X, Zuo YT, Hu Y, Zhang J, Zhou MX, Chen M, et al. Investigating the performance of three modified activated sludge processes treating municipal wastewater in organic pollutants removal and toxicity reduction. *Ecotoxicology and Environmental Safety*. 2018;148:729-737
- [81] Sehar S, Naz I. *Role of the Biofilms in Wastewater Treatment*. London: IntechOpen; 2016
- [82] Naz I, Saroj DP, Mumtaz S, Ali N, Ahmed S. Assessment of biological trickling filter systems with various packing materials for improved wastewater treatment. *Environmental Technology*. 2015;36:424-434
- [83] Oakley S, von Sperling M. *Media Filters: Trickling Filters and Anaerobic Filters*. California: Michigan State University; 2017
- [84] Visanji Z, Sadr SMK, Johns MB, Savic D, Memon FA. Optimising wastewater treatment solutions for the removal of contaminants of emerging concern (CECs): A case study for application in India. *Journal of Hydroinformatics*. 2020;22:93-110
- [85] Yang L, Yang L, Ding L, Deng F, Luo X-B, Luo S-L. *Principles for the Application of Nanomaterials in Environmental Pollution Control and Resource Reutilization*. Amsterdam: Elsevier; 2019
- [86] Jasim SY, Irabelli A, Yang P, Ahmed S, Schweitzer L. Presence of pharmaceuticals and pesticides in Detroit river water and the effect of ozone on removal. *Ozone Science and Engineering*. 2006;28:415-423
- [87] Esplugas S, Bila DM, Krause LGT, Dezotti M. Ozonation and advanced oxidation technologies to remove endocrine disrupting chemicals (EDCs) and pharmaceuticals and personal care products (PPCPs) in water effluents. *Journal of Hazardous Materials*. 2007;149:631-642
- [88] Gagnon C, Lajeunesse A, Cejka P, Gagné F, Hausler R. Degradation of selected acidic and neutral pharmaceutical products in a primary-treated wastewater by disinfection processes. *Ozone Science and Engineering*. 2008;30:387-392
- [89] Zhang H, Yamada H, Tsuno H. Removal of endocrine-disrupting chemicals during ozonation of municipal sewage with brominated byproducts control. *Environmental Science & Technology*. 2008;42:3375-3380
- [90] Segura P, Kaplan P, Yargeau V. Identification and structural elucidation of ozonation transformation products of estrone. *Chemistry Central Journal*. 2013;7:74
- [91] Tizaoui C. *Novel Ozone Oxidation Process for Emerging Contaminants Removal in Water*. Cham: Springer International Publishing; 2018
- [92] Tayo LL, Caparanga AR, Doma BT, Liao C-H. A review on the removal of pharmaceutical and personal care

- products (PPCPs) using advanced oxidation processes. *Journal of Advanced Oxidation Technologies*. 2018;**21**:196-214
- [93] Cesaro A, Belgiorno V. Removal of endocrine disruptors from urban wastewater by advanced oxidation processes (AOPs): A review. *Open Biotechnology Journal*. 2016;**10**:151-172
- [94] Sun Q, Zhu G, Wang C, Yang Z, Xue Q. Removal characteristics of steroid estrogen in the mixed system through an ozone-based advanced oxidation process. *Water, Air, and Soil Pollution*. 2019;**230**:9
- [95] Si X, Hu Z, Huang S. Combined process of ozone oxidation and ultrafiltration as an effective treatment technology for the removal of endocrine-disrupting chemicals. *Applied Sciences*. 2018;**8**:1240
- [96] Li X, Shi H, Li K, Zhang L. Combined process of biofiltration and ozone oxidation as an advanced treatment process for wastewater reuse. *Frontiers of Environmental Science & Engineering*. 2015;**9**:1076-1083
- [97] Paucar NE, Kim I, Tanaka H, Sato C. Effect of O₃ dose on the O₃/UV treatment process for the removal of pharmaceuticals and personal care products in secondary effluent. *ChemEngineering*. 2019;**3**:53
- [98] Yargeau V, Leclair C. Impact of operating conditions on decomposition of antibiotics during ozonation: A review. *Ozone Science and Engineering*. 2008;**30**:175-188
- [99] Chong MN, Jin B, Chow CWK, Saint C. Recent developments in photocatalytic water treatment technology: A review. *Water Research*. 2010;**44**:2997-3027
- [100] Martín-Pozo L, de Alarcón-Gómez B, Rodríguez-Gómez R, García-Córcoles MT, Çipa M, Zafra-Gómez A. Analytical methods for the determination of emerging contaminants in sewage sludge samples. A review. *Talanta*. 2019;**192**:508-533
- [101] Hernández F, Ibáñez M, Bade R, Bijlsma L, Sancho JV. Investigation of pharmaceuticals and illicit drugs in waters by liquid chromatography-high-resolution mass spectrometry. *TrAC Trends in Analytical Chemistry*. 2014;**63**:140-157
- [102] Pico Y, Belenguer V, Corcellas C, Diaz-Cruz MS, Eljarrat E, Farré M, et al. Contaminants of emerging concern in freshwater fish from four Spanish Rivers. *Science of the Total Environment*. 2019;**659**:1186-1198
- [103] Díaz-Cruz MS, García-Galán MJ, Guerra P, Jelic A, Postigo C, Eljarrat E, et al. Analysis of selected emerging contaminants in sewage sludge. *TrAC Trends in Analytical Chemistry*. 2009;**28**:1263-1275
- [104] Hird SJ, Lau BP-Y, Schuhmacher R, Krska R. Liquid chromatography-mass spectrometry for the determination of chemical contaminants in food. *TrAC Trends in Analytical Chemistry*. 2014;**59**:59-72
- [105] Farré M, Barceló D, Barceló D. Analysis of emerging contaminants in food. *TrAC Trends in Analytical Chemistry*. 2013;**43**:240-253
- [106] Tong L, Liu H, Xie C, Li M. Quantitative analysis of antibiotics in aquifer sediments by liquid chromatography coupled to high resolution mass spectrometry. *Journal of Chromatography. A*. 2016;**1452**:58-66
- [107] Cotton J, Leroux F, Broudin S, Poirel M, Cormann B, Junot C, et al. Development and validation of a multiresidue method for the analysis of more than 500 pesticides and drugs

in water based on on-line and liquid chromatography coupled to high resolution mass spectrometry. *Water Research*. 2016;**104**:20-27

[108] Robles-Molina J, Lara-Ortega FJ, Gilbert-López B, García-Reyes JF, Molina-Díaz A. Multi-residue method for the determination of over 400 priority and emerging pollutants in water and wastewater by solid-phase extraction and liquid chromatography-time-of-flight mass spectrometry. *Journal of Chromatography. A*. 2014;**1350**:30-43

[109] Poole CF. Alkylsilyl derivatives for gas chromatography. *Journal of Chromatography. A*. 2013;**1296**:2-14

[110] Arismendi D, Becerra-Herrera M, Cerrato I, Richter P. Simultaneous determination of multiresidue and multiclass emerging contaminants in waters by rotating-disk sorptive extraction-derivatization-gas chromatography/mass spectrometry. *Talanta*. 2019;**201**:480-489

[111] Albero B, Sánchez-Brunete C, Miguel E, Tadeo JL. Application of matrix solid-phase dispersion followed by GC-MS/MS to the analysis of emerging contaminants in vegetables. *Food Chemistry*. 2017;**217**:660-667

[112] Rutkowska E, Łozowicka B, Kaczyński P. Modification of multiresidue QuEChERS protocol to minimize matrix effect and improve recoveries for determination of pesticide residues in dried herbs followed by GC-MS/MS. *Food Analytical Methods*. 2018;**11**:709-724

[113] Zhang H, Bayen S, Kelly BC. Multi-residue analysis of legacy POPs and emerging organic contaminants in Singapore's coastal waters using gas chromatography-triple quadrupole tandem mass spectrometry. *Science of the Total Environment*. 2015;**523**:219-232

[114] Prebihalo S, Brockman A, Cochran J, Dorman FL. Determination of emerging contaminants in wastewater utilizing comprehensive two-dimensional gas-chromatography coupled with time-of-flight mass spectrometry. *Journal of Chromatography. A*. 2015;**1419**:109-115

[115] Jover E, Matamoros V, Bayona JM. Characterization of benzothiazoles, benzotriazoles and benzosulfonamides in aqueous matrixes by solid-phase extraction followed by comprehensive two-dimensional gas chromatography coupled to time-of-flight mass spectrometry. *Journal of Chromatography. A*. 2009;**1216**:4013-4019

[116] Matamoros V, Jover E, Bayona JM. Part-per-trillion determination of pharmaceuticals, pesticides, and related organic contaminants in river water by solid-phase extraction followed by comprehensive two-dimensional gas chromatography time-of-flight mass spectrometry. *Analytical Chemistry*. 2010;**82**:699-706

[117] Lima Gomes PCF, Barnes BB, Santos-Neto AJ, Lancas FM, Snow NH. Determination of steroids, caffeine and methylparaben in water using solid phase microextraction-comprehensive two dimensional gas chromatography-time of flight mass spectrometry. *Journal of Chromatography. A*. 2013;**1299**:126-130

[118] Ahmed M, Chin YH, Guo X, Zhao X-M. Microwave assisted digestion followed by ICP-MS for determination of trace metals in atmospheric and lake ecosystem. *Journal of Environmental Sciences*. 2017;**55**:1-10

[119] Wilschefska SC, Baxter MR. Inductively coupled plasma mass spectrometry: Introduction to analytical aspects. *Clinical Biochemist Reviews*. 2019;**40**:115-133

- [120] Lu Y, Gao X, Chen C-TA. Separation and determination of colloidal trace metals in seawater by cross-flow ultrafiltration, liquid-liquid extraction and ICP-MS. *Marine Chemistry*. 2019;**215**:103685
- [121] Pröfrock D, Prange A. Inductively coupled plasma–mass spectrometry (ICP-MS) for quantitative analysis in environmental and life sciences: A review of challenges, solutions, and trends. *Applied Spectroscopy*. 2012;**66**:843-868
- [122] Novak P, Zuliani T, Milačič R, Ščančar J. Development of an analytical procedure for the determination of polybrominated diphenyl ethers in environmental water samples by GC–ICP-MS. *Analytica Chimica Acta*. 2014;**827**:64-73
- [123] Jia X, Zhao J, Ren H, Wang J, Hong Z, Zhang X. Zwitterion-functionalized polymer microspheres-based solid phase extraction method on-line combined with HPLC–ICP-MS for mercury speciation. *Talanta*. 2019;**196**:592-599
- [124] Quintelas C, Mesquita DP, Ferreira EC, Amaral AL. Quantification of pharmaceutical compounds in wastewater samples by near infrared spectroscopy (NIR). *Talanta*. 2019;**194**:507-513
- [125] Salvatierra-stamp V, Muñiz-Valencia R, Jurado JM, Ceballos-Magaña SG. Hollow fiber liquid phase microextraction combined with liquid chromatography-tandem mass spectrometry for the analysis of emerging contaminants in water samples. *Microchemical Journal*. 2018;**140**:87-95
- [126] Guyader ME, Warren LD, Green E, Butt C, Ivosev G, Kiesling RL, et al. Prioritizing potential endocrine active high resolution mass spectrometry (HRMS) features in Minnesota lakewater. *Science of the Total Environment*. 2019;**670**:814-825
- [127] Llorca M, Lucas D, Ferrando-Climent L, Badia-Fabregat M, Cruz-Morató C, Barceló D, et al. Suspect screening of emerging pollutants and their major transformation products in wastewaters treated with fungi by liquid chromatography coupled to a high resolution mass spectrometry. *Journal of Chromatography. A*. 2016;**1439**:124-136
- [128] Petrie B, Youdan J, Barden R, Kasprzyk-Hordern B. Multi-residue analysis of 90 emerging contaminants in liquid and solid environmental matrices by ultra-high-performance liquid chromatography tandem mass spectrometry. *Journal of Chromatography. A*. 2016;**1431**:64-78
- [129] Comtois-Marotte S, Chappuis T, Vo Duy S, Gilbert N, Lajeunesse A, Taktek S, et al. Analysis of emerging contaminants in water and solid samples using high resolution mass spectrometry with a Q Exactive orbital ion trap and estrogenic activity with YES-assay. *Chemosphere*. 2017;**166**:400-411
- [130] Althakafy JT, Kulsing C, Grace MR, Marriott PJ. Liquid chromatography—Quadrupole Orbitrap mass spectrometry method for selected pharmaceuticals in water samples. *Journal of Chromatography. A*. 2017;**1515**:164-171
- [131] Peng Y, Gautam L, Hall SW. The detection of drugs of abuse and pharmaceuticals in drinking water using solid-phase extraction and liquid chromatography-mass spectrometry. *Chemosphere*. 2019;**223**:438-447
- [132] Campos-Mañas MC, Plaza-Bolaños P, Sánchez-Pérez JA, Malato S, Agüera A. Fast determination of pesticides and other contaminants of emerging concern in treated wastewater using direct injection coupled to highly sensitive ultra-high

performance liquid chromatography-tandem mass spectrometry. *Journal of Chromatography. A.* 2017;**1507**:84-94

[133] Osorio V, Schriks M, Vughs D, de Voogt P, Kolkman A. A novel sample preparation procedure for effect-directed analysis of micro-contaminants of emerging concern in surface waters. *Talanta.* 2018;**186**:527-537

[134] Casado J, Brigden K, Santillo D, Johnston P. Screening of pesticides and veterinary drugs in small streams in the European Union by liquid chromatography high resolution mass spectrometry. *Science of the Total Environment.* 2019;**670**:1204-1225

[135] Pinasseau L, Wiest L, Fildier A, Volatier L, Fones GR, Mills GA, et al. Use of passive sampling and high resolution mass spectrometry using a suspect screening approach to characterise emerging pollutants in contaminated groundwater and runoff. *Science of the Total Environment.* 2019;**672**:253-263

[136] Terzic S, Ahel M. Nontarget analysis of polar contaminants in freshwater sediments influenced by pharmaceutical industry using ultra-high-pressure liquid chromatography-quadrupole time-of-flight mass spectrometry. *Environmental Pollution.* 2011;**159**:557-566

[137] Caldas SS, Rombaldi C, de Oliveira Arias JL, Marube LC, Primel EG. Multi-residue method for determination of 58 pesticides, pharmaceuticals and personal care products in water using solvent demulsification dispersive liquid-liquid microextraction combined with liquid chromatography-tandem mass spectrometry. *Talanta.* 2016;**146**:676-688

[138] Andrés-Costa MJ, Carmona E, Picó Y. Universal method to determine acidic licit and illicit drugs and personal care products in water by liquid

chromatography quadrupole time-of-flight. *MethodsX.* 2016;**3**:307-314

[139] Vidmar J, Oprčkal P, Milačič R, Mladenovič A, Ščančar J. Investigation of the behaviour of zero-valent iron nanoparticles and their interactions with Cd²⁺ in wastewater by single particle ICP-MS. *Science of the Total Environment.* 2018;**634**:1259-1268

[140] Gutiérrez C, Fernández C, Escuer M, Campos-Herrera R, Rodríguez MEB, Carbonell G, et al. Effect of soil properties, heavy metals and emerging contaminants in the soil nematodes diversity. *Environmental Pollution.* 2016;**213**:184-194

[141] Marcinkowska M, Barańkiewicz D. Multielemental speciation analysis by advanced hyphenated technique—HPLC/ICP-MS: A review. *Talanta.* 2016;**161**:177-204