

Simulation Study on CCD Tomography System for Ruby Stone Optical Properties

Syarfa Najihah Raisin¹, Juliza Jamaludin^{1*}, Irneza Ismail¹, Yasmin Abdul Wahab², Ruzairi Abdul Rahim³, Mus'ab Sahrim¹, Sharma Rao Balakrishnan¹, Wan Zakiah Wan Ismail¹, Fatinah Mohd Rahalim¹, Farah Aina Mohd Jamal³, Nurul Arina Hazwani Samsu Zaini³

¹Faculty of Engineering and Built Environment, Universiti Sains Islam Malaysia (USIM), 71800 Negeri Sembilan Malaysia.

²Faculty of Electrical & Electronics Engineering Technology, Universiti Malaysia Pahang, Pekan Campus, 26600 Pekan, Pahang, Malaysia.

³School of Electrical Engineering, Faculty of Engineering, Universiti Teknologi Malaysia, UTM Johor Bahru, 81310 Johor, Malaysia.

Corresponding author* email: juliza@usim.edu.my
Accepted 3 March 2021, available online 31 March 2021

ABSTRACT

Ninety percent of the ruby stones available worldwide come from Myanmar. Malaysia is known to be one of the countries that have been importing ruby stones for precious stone industries, manufacturing industries, medical and dentistry applications. There are several gemology tools which are used to investigate the grading of ruby stones such as loop, microscope, and dichroscope. Nevertheless, these tools are highly dependable on human visual assessment and require years of experience that may lead to error since ruby stone quality is evaluated based on its clarity and transparency. Hence, this paper addresses a simulation study on the optical properties of ruby stones via Charge-Coupled Device (CCD) Tomography approach. This paper indicates the capability of CCD and tomography system to analyze the ruby stone optical properties through image reconstruction based on the previous research. Linear Back Projection (LBP) algorithm will be used to construct two-dimensional image reconstruction of varieties ruby stones. From these image reconstructions, the transparency and blemishes of ruby stones can be analyzed.

Keywords: Ruby Stone, Object Transparency, Charged-Coupled Device (CCD), Tomography

1. Introduction

The optical property of ruby stone is beneficial for quantitative grading of this gemstone towards the gemologists, stones industries, manufacturing industries (drilling and cutting), medical and dentistry application. The grading valuation of ruby stone is categorized by its transparency and blemishes. There is a specific characterization of diamonds that influence their value and uniqueness. However, the impact of pricing differs. These characteristics are referred to 4Cs which are the carat weight, clarity, colour and cut [1]. The weight of a ruby is measured in carats. Five karats = 1 gram [2]. The higher the weight of the carat, the rarer the ruby thus the greater its value when all other conditions are equal from one variety towards another. Illustrated below is the approximate appearance of a well-cut oval-shaped ruby for the given carat weight.



Figure 1. The approximate appearance of a well-cut oval-shaped ruby for a given carat weight [2]

The substances trapped within the gem known as inclusions relatively indicate the clarity grading of the gemstone. A gemstone's clarity grade indicates the relative absence of inclusions (materials trapped inside the gem), cracks and blemishes (surface deficiencies) affecting its appearance and surface area. There are very different clarity criteria for opaque and translucent gems than for clear gems [3].

Colour has an important role in the diamond demonstration. For some consumers, it's a hard C to comprehend, but it is an important part of the entire value view that is required to make purchasing decisions. Ruby differs in colour depending largely on their chromium and iron content. Consequently, rubies have various prevalent colours from different parts of the world such as in Cambodia, India, Myanmar, Sri Lanka, Tanzania, Vietnam, India, Tajikistan and Pakistan. Rubies, mainly red, span from brownish and purple to orange and pinkish. The most commonly used method of colour grading is the one established by GIA [4]. It has 23 grades of letters that run from D (colourless) to Z (light yellow, brown, or grey).

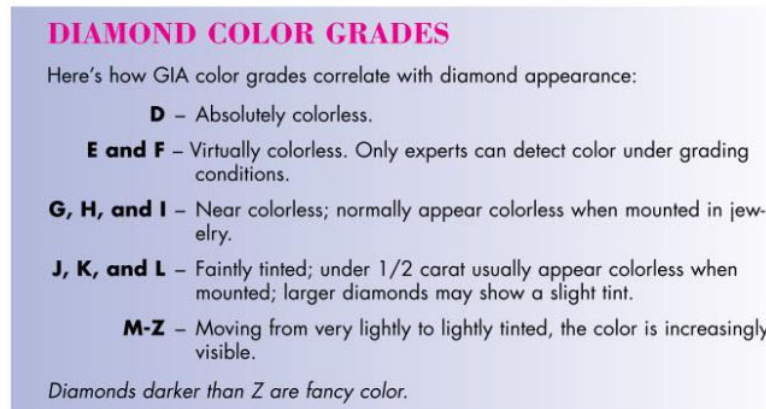

Figure 2. The diamond colour grade based on GIA [4].

Cutting is the most difficult aspect of the 4Cs [4] from a theoretical point of view. But it is also the top beauty attribute for the majority of diamonds. It has a huge influence on the appearance of a gem. Cut corresponds to the precision of the angles, ratios, proportion and shine of the ruby. It has a major effect on how light passes within the ruby and how it exits in the form of brilliance. There are five ways to classify the quality of gemstones based on their cut on the criteria of Clerk [5]; symmetry, magnification, contrast with similar stones, windows and cabochons. However, most gems are meant to have normal shapes. There are numerous gemology tools to investigate the ruby stone grading valuation. Available devices such as binocular microscope loupe [6] and portable dielectric tunable forensic lens [7] are used for ruby stone inspection. The basic principle of the system is magnifying the image of the ruby stone structure for visual inspection. Nevertheless, this is not a systematic and standardized technique to identify the grading of ruby stone transparency and blemishes. Therefore, this paper focuses on the optical properties of ruby stone via LabVIEW programming simulation through CCD and Tomography approaches.

2. Methodology

The main aim of this paper is to introduce a simulation study on CCD tomography system for ruby stone optical properties. Meanwhile, two objectives had been selected in order to gain the main aim of this research, that is to examine the light intensity of ruby stone based on theoretical value, which involves the light refraction and the absorption effect to the ruby stone. The next objective is to design conceptual modelling of CCD tomography approach using LabVIEW software. This could be done by establishing the octogen orientation concept for the CCD and ruby stone placement for conceptual modelling. The data used in this simulation is provided from the first objective.

2.1 Optical properties of Ruby Stone

From Figure 3, it shows the light passes through two different mediums which are air and ruby stone. As light passes through different object medium, light attenuation will occur due to light absorption, light reflectance and light scattering. As the complex mathematical model, light scattering and the diffraction effect are neglected in this calculation with the additional fact that the wavelength of light incident used (laser light) is too small compared to the size of diameter of the interest object [7]. This can be concluded that there are two types of algorithms involved in this simulation, which is light attenuation due to;

1. Light absorption.
2. Light reflectance.

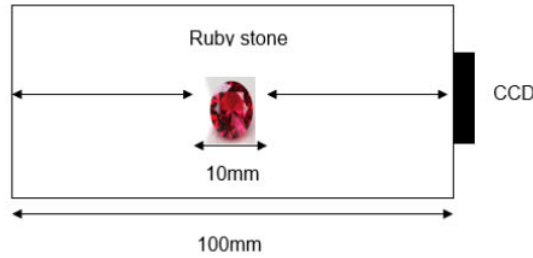

Figure 3. Light penetration through ruby stone and CCD.

2.1.1 Light absorption

Light is attenuated when it passes through from a medium to another medium, where attenuation phenomena happened due to absorption. All the three different mediums consist of respectively coefficient value α which will be used in the Beer-Lambert Law shown below.

$$I_{out} = I_{in}e^{-\alpha x} \quad (1)$$

From this formula, the output of light intensity is multiplied by the exponential attenuation of medium density when light passes through it. Whereby, x is the distance of light transverse.

2.1.2 Light reflectance

Energy of photo (light) will decrease when light goes through the different medium or passes through any object next to it. The light reflectance equation is

$$I_{Final\ reflection1} = I_{initial} - \left[I_{initial} \left(\frac{n_2 - n_1}{n_2 + n_1} \right)^2 \right] \quad (2)$$

$$R = \left(\frac{n_2 - n_1}{n_2 + n_1} \right)^2 \quad (3)$$

R = Reflection ration
 n_1 = Transmitted refractive index
 n_2 = Incidence refractive index

Both of this light attenuation due to absorption and light reflectance are integrated to produce mathematical expression for this project.

2.2 Mathematical expression for a system consists of a laser, ruby stone and CCD.

Firstly, as a source of light entered the black box, I_i (light intensity) is reduced due to the reflection at the air/ruby stone interface.

$$\begin{aligned} I'_1 &= I_i - I_{reflection1} = I_i - \left[I_i \left(\frac{n_{rubystone} - n_{air}}{n_{rubystone} + n_{air}} \right)^2 \right] \\ I'_1 &= I_i - \left[I_i \left(\frac{1.762 - 1}{1.762 + 1} \right)^2 \right] = 0.9238I_i \end{aligned} \quad (4)$$

Light is then absorbed when travelling through a ruby stone.

$I_2 = I'_1 e^{-(\alpha_{rubystone} x 10mm)}$ where the $\alpha_{rubystone}$ is $0.003mm^{-1}$ and the ruby stone length is assume, $X = 10mm$

$$I_2 = I'_1 e^{-(0.003mm^{-1} \times 10mm)} = 0.99I'_1$$

$$I_2 = 0.9238I_i \quad (5)$$

$$I_2' = I_2 - I_{reflection2} = I_2 - \left[I_2 \left(\frac{n_{air} - n_{rubystone}}{n_{air} + n_{rubystone}} \right)^2 \right]$$

$$I_2' = I_2 - \left[I_2 \left(\frac{1 - 1.762}{1 + 1.762} \right)^2 \right] = 0.9238I_2$$

$$I_2' = 0.8535I_i \quad (6)$$

I_2 is further reduced at the ruby stone/air interface.

The final light intensity ratio when a light strike through the ruby stone with $n_{rubystone} = 1.762$ and $\alpha_{rubystone}$ is $0.003mm^{-1}$ is $\frac{I_2'}{I_i} = 0.8535$.

2.3 Image Reconstruction

Laboratory Virtual Instrument Engineering Workbench (LabVIEW) is National Instruments' system-design framework and visual programming language development environment [8]. LabVIEW is widely used on a range of operating systems (OSs), including Microsoft Windows, various versions of Unix, Linux, and macOS, for data collection, instrument control, and industrial automation. In this project, the image is produced based on the Linear Back Projection (LBP) algorithm. Figure 4 and 5 show the graphical coding for both light attenuation due to light absorption and light refraction respectively.

- i. Light absorption equation and the LabVIEW modelling graphical code.

$$I_{out} = I_{in}e^{-\alpha x}$$

$$I_4 = 0.6408I_i \quad (7)$$

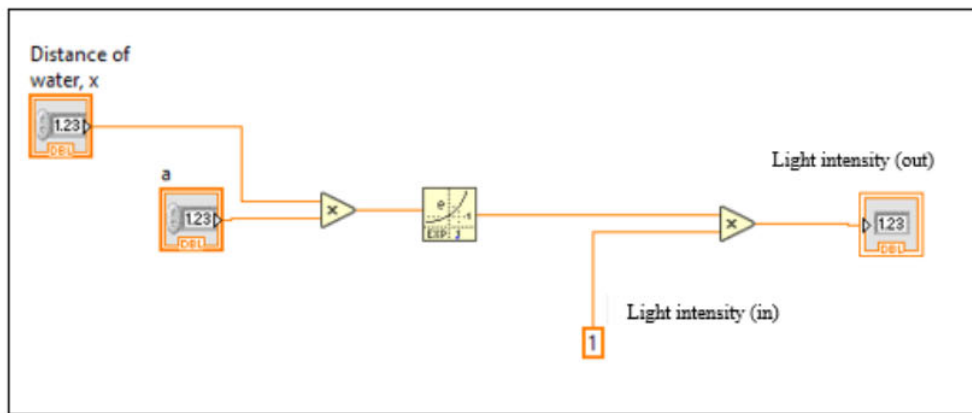

Figure 4. LabVIEW coding for light absorption calculation

- ii. Light reflection equation and the LabVIEW modelling graphical code.

$$I_{Final\ reflection1} = I_{initial} - \left[I_{initial} \left(\frac{n_2 - n_1}{n_2 + n_1} \right)^2 \right] \quad (8)$$

$$R = \left(\frac{n_2 - n_1}{n_2 + n_1} \right)^2 \quad (9)$$

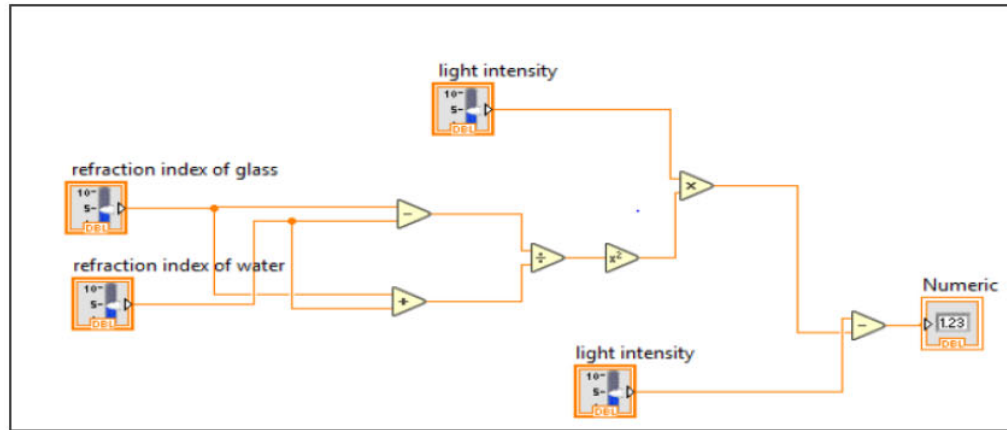

Figure 5. LabVIEW coding for light reflection calculation

This algorithm method is repeated for 160 times to get a clearer view as the number of pixels increases when the number of sensors used for the algorithm is increasing. The Equation (10) is shown below and the following figure shows the single linear projection view of the construction of 2D image [9].

$$V_{LBP (160 \text{ views})}(x, y) = \sum_{tx=0}^{159} \sum_{rx=0}^{159} S_{tx,rx} x \bar{M}_{tx,rx} \quad (10)$$

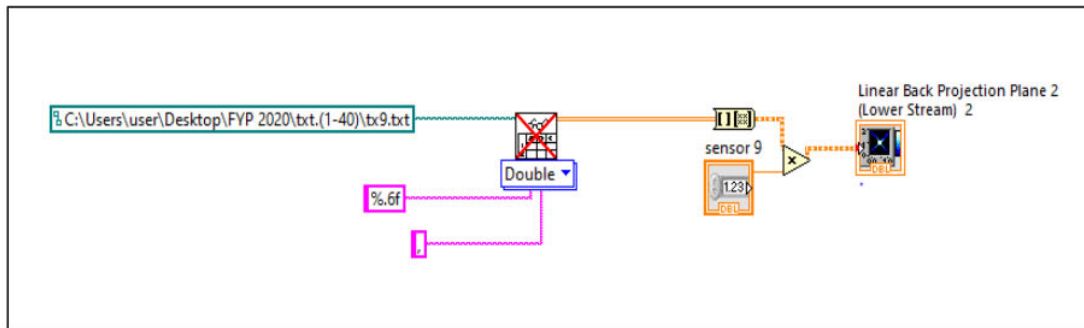

Figure 6. Single view of linear back projection algorithm

3. Results

This research will apply the CCD tomography technique to investigate the transparency and blemishes of ruby stone. This is a non-invasive and non-intrusive technique which can determine the optical properties of an object accurately [10]. CCD, a light-sensitive integrated circuit that stores and displays the data of an image, will convert the light intensity received to the output voltage form. Research has been done by J.Jamaludin [11] [12] [13] on the optical tomography system using CCD. From these studies, CCD Sony ILX551A worked effectively with a low power laser diode, which is a red-light source. This CCD optical tomography system is capable to identify the existence of different object transparency and blemishes in crystal-clear water. The object transparency and blemishes classification are done by analyzing the light intensity received by CCD optical tomography after penetrating the object. Figure 7 shows the upper view of CCD optical tomography with the red-light source. The dark blue is the object which exists in the cylindrical pipeline full of crystal-clear water [11].

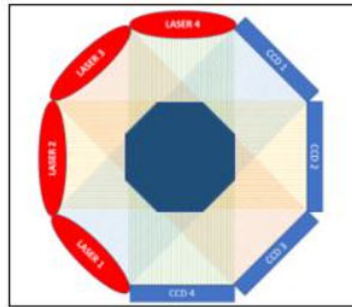

Figure 7. Upper view of CCD optical tomography with the red light source [11]

In 2020, S.N. Raisin [14] had constructed a simulation using LabVIEW programming to distinguish the image reconstruction detected by CCD in optical tomography method. This research will be the guideline for the expected output from different transparency and clarity of a ruby stone. Table 1 below shows the simulation for the image detected with different size of diameter, transparency and opacity [14].

Table 1. The comparison for the image detected with different transparency and opacity [14].

Transparent Object	Solid Object
<p style="text-align: center;">(a)</p>	<p style="text-align: center;">(b)</p>
<p style="text-align: center;">(c)</p>	<p style="text-align: center;">(d)</p>

4. Discussions

The first simulation is done by assuming the size of (a) transparent object and the (b) solid object is 2mm. Table 1(a) and (b) showed sensors 20, 21, 22, 60, 61, 62, 100, 101, 102, 140, 141 and 142 are used to get the intercept modelling location of the transparent and solid object when the size of diameter is 2mm. The second simulation is done by assuming the size of (c) transparent object and the (d) solid object is 5mm. Table 1 (c) and (d) showed sensors 16, 17, 18, 19, 20, 21, 22, 56, 57, 58, 59, 60, 61, 62, 96, 97, 98, 99, 100, 101, 102, 136, 137, 138, 139, 140, 141 and 142 are used to get the intercept modelling location of the transparent and solid object when the size of diameter is 5mm [14].

5. Conclusion

In conclusion, this paper indicates the capability of CCD and tomography system to analyze the ruby stone optical properties through image reconstruction. To validate this hypothesis, two objectives were outlined and need to be achieved as well throughout this project simulation development. The first objective is to model the light characteristic equation based on the optical tomography system. The first objective is indeed a crucial point to gain. The proposed block diagram of ruby stone in the CCD tomography system consists of an arrangement of a different medium, which will attenuate the light incident from the laser beam before it reaches the CCD. The laser was the transmitter while the CCD was the receiver. The second objective is to construct the 2-D images that was proven by the previous research through the comparison of different level of object transparency. The images of captured data are reconstructed based on Linear Back Projection (LBP) Algorithm shows that the difference images formed as different level of object opacity placed in the measurement section.

Acknowledgement

The authors would like to thank to Universiti Sains Islam Malaysia and ADS research group for their cooperation in this research paper. The research is supported by the Fundamental Research Grant Scheme Ministry of Higher Education Malaysia (FRGS/1/2020/WAB07/USIM/02/1).

References

- [1] D. Council, "Begining Jewelry sales," vol. 7, 2014.
- [2] *Ruby Guide*, Italy: CIBJO, The World Jewellery Confederation, 2008.
- [3] "What Do the GIA Gem Clarity Grading Codes Mean?," Gem Society, [Online]. Available: <https://www.gemsociety.org/article/gia-gem-clarity-grading-codes>. [Accessed 22 January 2021].
- [4] "A Consumer's Guide to Gem Grading.," International Gem Society, [Online]. Available: <https://www.gemsociety.org/article/a-consumers-guide-to-gem-grading>. [Accessed 11 2021].
- [5] S. Mukherjee, "Applied mineralogy: applications in industry and environment.," *Springer Science & Business Media*, 2012.
- [6] Liao, Kai-Wei, K. J. Lu, R. C. Luo and J. A. Yeh., "Portable dielectric tunable forensic lens design for jadeite analysis.," *International Conference on Optical MEMS and Nanophotonics (OMN)*, 2016.
- [7] M. Idroas, "A charge coupled device based optical tomography instrumentation system for particle sizing," *Ph. D, Sheffield Hallam University*, 2004.
- [8] T. Jeffrey and K. Jim, *LabVIEW for Everyone: Graphical Programming Made Easy and Fun (3rd Edition)*, (National Instruments Virtual Instrumentation Series), vol. 79, 2006.
- [9] J. Jamaludin and R. A. Rahim, "Online optical tomography system for detecting and measuring the diameters of solid and transparent objects.," *IEEE Sensors Journal*, vol. 16, no. 16, pp. 6175-6183, 2016.
- [10] J. Jamaludin, M. Z. Zawahir, R. A. Rahim, F. R. M. Yunus, N. M. N. Ayob, S. R. A. Muhammad, N. S. Fadzil, Z. Zakaria and M. H. F. Rahiman, "A review of tomography system," *Jurnal Teknologi*, vol. 64, no. 5, pp. 47-51, 2013.
- [11] J. Jamaludin, R. A. Rahim, M. H. F. Rahiman and J. M. Rohani, "Charge-coupled device based on optical tomography system for monitoring two-phase flow.," *Electronics Letters*, vol. 53, no. 5, pp. 331-333, 2017.
- [12] J. Jamaludin, R. A. Rahim, H. A. Rahim, M. H. F. Rahiman, S. Z. M. Muji and J. M. Rohani., "Charge coupled device based on optical tomography system in detecting air bubbles in crystal clear water." *Flow Measure, Flow Measurement and Instrumentation*, vol. 50, pp. 13-25, 2016.
- [13] J. Jamaludin, R. A. Rahim, H. A. Rahim, H. F. Rahiman, S. Z. M. Muji, N. S. M. Fadzil and L. P. Ling, "Introducing an Application of a Charged Coupled Device (CCD) in an Optical Tomography System.," *Jurnal Teknologi*, vol. 73, no. 3, pp. 97-102, 2015.
- [14] S. N. Raisin, *LabVIEW Programming for the Investigation of Object Transparency Via Charge-Coupled Device Assessment*, Undergraduate, Universiti Sains Islam Malaysia, 2020.