

REDESIGN A MODEL OF 32 INCH LCD TV BRACKET

ZAITUN BINTI MOHD DESAH

A report submitted in fulfillment  
of the requirements for the award  
of the Diploma of Mechanical  
Engineering

Faculty of Mechanical Engineering  
University Malaysia Pahang

APRIL 2009

## SUPERVISOR'S DECLARATION

"I hereby declare that I have read this project report and in my opinion this project report is sufficient in terms of scope and quality for the award of the Diploma of Mechanical Engineering"

Signature : .....

Name of Supervisor : Mr. Zamri Bin Mohamed

Date : 18 Mei 2009

## DECLARATION

I declare that this report entitled “Redesign A Model Of 32 Inch LCD TV Bracket ” is the result of my own research except as stated in the references. The report has not been accepted for any degree and is not concurrently submitted in candidature of any other degree.

Signature : .....

Name : Zaitun Binti Mohd Desah

Date :18 Mei 2009

## **DEDICATION**

To my parents, sisters and friends, without whom and his/her lifetime efforts, my pursuit of higher education would not have been possible and I would not have had the chance to study for a mechanical course.

Also to my supervisor, Mr. Zamri Bin Mohamed and Mechanical Staff, without whose wise suggestions, helpful guidance and direct assistance, it could have neither got off the ground nor ever been completed.

## **ACKNOWLEDGEMENT**

This project was conducted under the supervision of Mr. Zamri Bin Mohamed in University Malaysia Pahang formerly known as KUKTEM. I am very grateful for his patience and constructive comments that enriched this research project. His time and efforts have been a great contribution during the preparation of this thesis that cannot be forgotten for ever. I would like to thank to lecturer and technician in faculty of mechanical engineering for their valuable comments and sharing their time and knowledge on this research project during the project was carried out. I also gratefully acknowledge the assistance of everybody who helped in the execution of this project in UMP. I also thank to all Mechanical students for their friendship and help when thinking through problems and for sharing their knowledge of experimental apparatus and computer systems. Finally, I thank my family for their continuous support and confidence in my efforts.

## ABSTRACT

This project is about redesign and fabricating a model of 32 inch LCD TV bracket. Its function is to mount the 32 inch LCD TV to the wall in vertical position more efficiently. This project involves the process of redesigning a model for 32 inch LCD TV bracket by considering the shape and also the ergonomic factor for people to use. After the design has completed, it was transformed to its model product where the design is used for guideline. This project also required analysis to make sure the strength of the product to ensure the safety for the user indeed of publishing. Numerous methods and process involve in this project for assembly each parts by using bolt, lag bolt, lag washer, bolt washer and washer. This project is mainly about redesign a model for 32 inch LCD TV by referring to an existing product as guidance. This new product is design for 32 inch screen LCD TV that is mount to the wall vertically in static. The weight is more light, the panel thickness also thicker than the existing product and the price is more cheaper and affordable. After all the process had been done, this model of 32 inch LCD TV bracket may help us to understand the fabrication and redesigning process that involved in this project.

## ABSTRAK

Projek ini ialah mengenai merekabentuk semula dan membina model untuk penyangkut LCD TV 32 inci. Ia berfungsi untuk menyangkut LCD TV 32 inci di dinding secara menegak dengan lebih efisien. Projek ini melibatkan proses merekabentuk semula sebuah model penyangkut LCD TV 32 inci dengan mengambil kira bentuk dan faktor ergonomik untuk kegunaan pengguna. Selepas rekabentuknya siap, model produk dihasilkan dengan mengikut rekabentuk yang telah disediakan. Projek ini juga memerlukan analisis untuk memastikan keselamatan pengguna serta pengeluarannya. Beberapa kaedah dan proses terlibat dalam projek ini untuk menyambung setiap bahagian dengan menggunakan beberapa jenis palang dan pengetat palang. Keutamaan projek ini ialah mengenai merekabentuk semula sebuah model penyangkut untuk LCD TV 32 inci dengan merujuk kepada produk sedia ada sebagai contoh. Produk baru ini direka untuk LCD TV 32 inci yang disangkut ke dinding secara menegak dalam keadaan pegun. Beratnya lebih ringan, ketebalan panel adalah lebih nipis daripada produk sedia ada dan harganya lebih murah dan mampu dimiliki. Selepas semua proses telah disediakan, penyangkut LCD TV 32 inci ini boleh membantu kita memahami cara menghasilkan dan merekabentuk semula produk yang terlibat di dalam projek ini.

**TABLE OF CONTENTS**

<b>CHAPTER</b>	<b>TITLE</b>	<b>PAGE</b>
	<b>FRONT PAGE</b>	<b>ii</b>
	<b>SUPERVISOR'S DECLARATION</b>	<b>iii</b>
	<b>WRITER DECLARATION</b>	<b>iv</b>
	<b>DEDICATION</b>	<b>v</b>
	<b>ACKNOWLEDGEMENT</b>	<b>vi</b>
	<b>ABSTRACT</b>	<b>vii</b>
	<b>ABSTRAK</b>	<b>viii</b>
	<b>TABLE OF CONTENT</b>	<b>ix</b>
	<b>LIST OF FIGURE</b>	<b>xii</b>
	<b>LIST OF TABLE</b>	<b>xiii</b>
	<b>LIST OF PICTURE</b>	<b>xiv</b>
<b>1</b>	<b>INTRODUCTION</b>	<b>1</b>
	<b>1.1 Project Synopsis</b>	
	<b>1.2 Project Problem Statement</b>	<b>2</b>
	<b>1.3 Project Objective</b>	<b>2</b>
	<b>1.4 Project Scope</b>	<b>2</b>
	<b>1.5 Project Background</b>	<b>3</b>
<b>2</b>	<b>LITERATURE REVIEW</b>	<b>4</b>
	<b>2.1 Introduction</b>	<b>4</b>



	<b>2.2 Pre Review</b>	<b>4</b>
	<b>2.3 Review Current Design</b>	<b>5</b>
	<b>2.3.1 LCD TV Wall Mount</b>	<b>5</b>
	<b>2.3.2 Product Information For Example Product</b>	<b>7</b>
	<b>2.3.3 Example Of LCD TV</b>	<b>8</b>
	<b>2.4 Stainless Steel</b>	<b>9</b>
<b>3</b>	<b>METHODOLOGY</b>	<b>16</b>
	<b>3.1 Introduction</b>	<b>16</b>
	<b>3.1.1 Shape Of The 32 Inch LCD TV Bracket</b>	<b>17</b>
	<b>3.1.2 Cost</b>	<b>17</b>
	<b>3.1.3 32 Inch LCD TV Bracket Availability</b>	<b>17</b>
	<b>3.1.4 Material</b>	<b>17</b>
	<b>3.2 Project Flow Diagram</b>	<b>18</b>
	<b>3.3 Project Planning</b>	<b>20</b>
<b>4</b>	<b>RESULT AND DISCUSSION</b>	<b>22</b>
	<b>4.1 Introduction</b>	<b>22</b>
	<b>4.2 Design Specification</b>	<b>23</b>
	<b>4.3 Design Selection</b>	<b>23</b>
	<b>4.3.1 Propose Design</b>	<b>23</b>
	<b>4.4 Pugh Selection Method</b>	<b>28</b>
	<b>4.5 Brainstorming</b>	<b>29</b>
	<b>4.6 Raw Material And Apparatus</b>	<b>30</b>
	<b>4.7 Fabrication Process</b>	<b>31</b>
	<b>4.8 Procedure Setup</b>	<b>32</b>
	<b>4.9 Steps Of Fabrication Process</b>	<b>32</b>
	<b>4.10 Manufacturing Cost</b>	<b>33</b>
	<b>4.11 Analysis About The Material Use</b>	<b>34</b>

	<b>4.12 Analysis About The Product</b>	<b>35</b>
<b>5</b>	<b>CONCLUSION</b>	<b>36</b>
	<b>5.1 Summary Of The Project</b>	<b>36</b>
	<b>5.2 Future Work</b>	<b>37</b>
	<b>5.3 Conclusion</b>	<b>37</b>
	<b>APPENDICES A-C</b>	<b>38</b>
	<b>REFERENCES</b>	<b>46</b>

**LIST OF FIGURE**

<b>FIGURE</b>	<b>TITLE</b>	<b>PAGE</b>
1.	<b>Articulating Swivel Wall Mount</b>	<b>5</b>
2.	<b>Tilt/Swivel Wall Mount Dedicated</b>	<b>6</b>
3.	<b>Flat Wall Mount</b>	<b>6</b>
4.	<b>LCD TV Wall Mount</b>	<b>6</b>
5.	<b>32'' HD Ready LCD TV</b>	<b>8</b>
6.	<b>32 Inch HD Ready LCD TV Dimensions</b>	<b>8</b>
7.	<b>Fiber Glass Strains</b>	<b>10</b>
8.	<b>LCD TV Wall Mount</b>	<b>24</b>
9.	<b>LCD TV Simple Wall Mount</b>	<b>25</b>
10.	<b>LCD TV Easy Bracket</b>	<b>26</b>
11.	<b>LCD TV Bracket</b>	<b>27</b>
12.	<b>LCD TV Bracket</b>	<b>29</b>

**LIST OF TABLE**

<b>TABLE</b>	<b>TITLE</b>	<b>PAGE</b>
<b>1.</b>	<b>Gantt Chart</b>	<b>20</b>
<b>2.</b>	<b>Advantages And Disadvantages Of LCD TV Wall Mount</b>	<b>24</b>
<b>3.</b>	<b>Advantages And Disadvantages Of LCD TV Simple Wall Mount</b>	<b>25</b>
<b>4.</b>	<b>Advantages And Disadvantages Of LCD TV Easy Bracket</b>	<b>26</b>
<b>5.</b>	<b>Advantages And Disadvantages Of LCD TV Bracket</b>	<b>27</b>
<b>6.</b>	<b>Pugh Selection Method</b>	<b>28</b>
<b>7.</b>	<b>Characteristic Of Three Different Material</b>	<b>34</b>
<b>8.</b>	<b>Gantt Chart</b>	<b>40</b>

**LIST OF PICTURE**

<b>PICTURE</b>	<b>TITLE</b>	<b>PAGE</b>
1.	32 Inch LCD TV Bracket	38
2.	Parts Mount To The Wall	39
3.	Parts Mount To The LCD TV	39
4.	A Model Of 32 Inch LCD TV Bracket	41
5.	Lag Bolt, Concrete Anchor, And Lag Washer	42
6.	Bolt And Washer	42
7.	Front Side Of Bending Machine	43
8.	Back Side Of Bending Machine	44
9.	CNC Plasma Cutting Machine	44
10.	Shearing And Punch Machine	45



## **CHAPTER 1**

### **INTRODUCTION**

#### **1.1 Project Synopsis**

The project contains of redesigning and fabrication of a 32 inch LCD TV bracket. The material use in this project will reduce the mass of the LCD TV bracket and also provided safety to mount it to the wall vertically. The fabrication required student to familiar the procedure and safety on handling heavy machine use that is drilling, punching and bending machine and also welding process. The project also require student to do research and study on what is the most suitable design and material should be use.

## **1.2 Project Problem Statement**

The common LCD TV bracket is heavy and very expensive. Although it is more secure and safe to be use, the assembly process needs a professional to do it. If you are not be careful, you might get injured or your LCD TV will break down. This new redesign LCD TV bracket is create not only easy to assemble, it is also affordable and more light. Everybody can hang their LCD TV easily and safely. With less tools to be use and material that is ergonomic, you don't have to worry about the secure of yourself to hang it and you can enjoy watching television with your family safely.

## **1.3 Project Objective**

The objectives of this project are:

- Redesign a model for 32 inch LCD TV bracket
- Fabricate a model for 32 inch LCD TV bracket using a fibreglass sheet

## **1.4 Project Scope**

The specific scope of this project is to: -

- Redesign and fabricate a model of 32 inch LCD TV bracket
- Making analysis of the material for 32 inch LCD TV bracket



## 1.5 Project Background

Liquid-colour display televisions(LCD TV) are television sets that use LCD technology to produce images. Benefits of LCD technology include lower weight and reduced power requirements when compared to other display types. Often, LCD television screens can also be used as computer monitors. For better view to watch the television, a bracket is create to mount the LCD TV to the wall. Nowadays, there are variety of bracket sells. But it is quite expensive and needs a professional to assemble to the wall. People would want an item that affordable and can less cost. So, this new redesign of LCD TV bracket is the solution. It is easier to assemble, more light and less tools to be use. The fabricating process also has been reduce and its using stainless steel sheet that is more light than cold steel. Using punch machine to cut the stainless steel sheet with dimension needed, than using bending machine to bend it, and drill the hole using drilling machine. For joining process, It use lag bolt, concrete anchor and lag washer to mount to the wall and to assemble the bracket using bolt and washer.

## **CHAPTER 2**

### **LITERATURE REVIEW**

#### **2.1 Introduction**

This chapter will cover the summarizing of all the literature review gathered from many academic source.

#### **2.2 Pre Review**

Liquid-colour display televisions(LCD TV) are television sets that use LCD technology to produce images. Benefits of LCD technology include lower weight and reduced power requirements when compared to other display types. Often, LCD television screens can also be used as computer monitors.

Nowadays, people use to mount their LCD TV to the wall. It makes their house look elegance and rich with the right position and sight of view to mount it. The LCD TV bracket is create to easier their work to mount the LCD TV to the wall. There are variety shape and size of LCD TV bracket. You can choose any pattern of LCD TV bracket existed. But, the price might be very expensive because it use expensive material, many tools given to assemble the bracket and assemble them to the wall and you may also need to pay more to hire a professional to assemble them for you at the right side of your home.

## **2.3 Review Current Design**

### **2.3.1 LCD TV Wall Mount**



Figure 1 :Articulating swivel wall mount

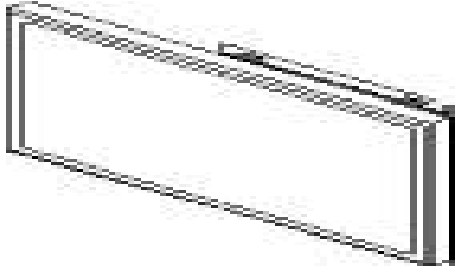

Figure 2 :Tilt/swivel wall mount dedicated

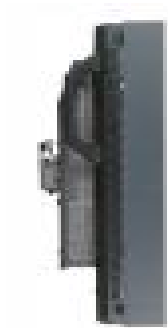

Figure 3 :Flat wall mount dedicated- for 21" to 39 screen

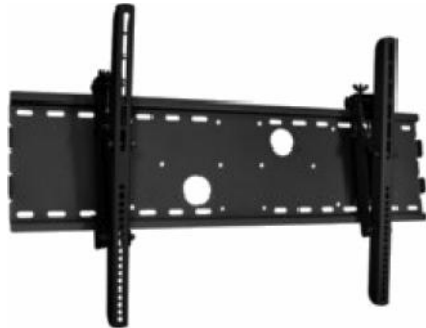

Figure 4 :LCD TV wall mount

### **2.3.2 Product Information For Example Product**

This adjustable tilting wall mount supports 37" to 63" LCD and Plasma TVs up to 165 lbs. This professionally designed mount allows for a 15 degree tilt, to optimize your viewing angle from a couch or seating area. This mount is perfect for boardrooms, digital signage, or home theaters. The back of the display sits about 4 inches off the wall for a sleek installation. The kit includes everything you need for installation, including easy-align brackets and a unique wall plate that can be mounted to a single wood stud, two wood studs, or concrete.

Dimensions: Wall plate: 32" x 8 7/8" Measurements are from edge to edge. Mounting points for bolts will be shorter. Please see above.

Range of Motion: Tilt: 0 degree to 15 degrees down and up(variable) ,swivel: none ,extension from wall: 4.0" when parallel to the wall.

Design & construction: Solid toughened steel construction ,durable scratch resistant finish in Silver ,easy installation – TV is lifted onto the mount from the front, no clearance necessary, except a few inches above.

Included in box: Mount ,mounting hardware and user manual

### 2.3.3 Example Of LCD TV



Figure 5 : 32" HD Ready LCD TV

This is the example of LCD TV 32 inch screen size. With a design that is simply redefined, the SAMSUNG LCD TV Series 4 delivers delight to your eyes. Its' slim style refreshes your living space and uplifts your emotions, creating entertainment that is more enjoyable. Its' pristine picture quality offers an outstanding HDTV experience that redefines how you connect with the digital



Figure 6 : 32 inch HD ready LCD TV dimensions

## 2.4 Stainless Steel

In metallurgy, stainless steel is defined as a steel alloy with a minimum of 10% chromium content by mass.<sup>[1]</sup> Stainless steel does not stain, corrode, or rust as easily as ordinary steel (it *stains less*), but it is not stain-proof.<sup>[2]</sup> It is also called corrosion-resistant steel or CRES when the alloy type and grade are not detailed, particularly in the aviation industry. There are different grades and surface finishes of stainless steel to suit the environment to which the material will be subjected in its lifetime. Common uses of stainless steel are cutlery and watch straps.

Stainless steel differs from carbon steel by amount of chromium present. Carbon steel rusts when exposed to air and moisture. This iron oxide film is active and accelerates corrosion by forming more iron oxide. Stainless steels have sufficient amount of chromium present so that a passive film of chromium oxide forms which prevents further surface corrosion and blocks corrosion spreading in the metal's internal structure.



Figure 7 : Fibreglass strains

History of stainless steel: A few corrosion-resistant iron artifacts survive from antiquity. A famous (and very large) example is the Iron Pillar of Delhi, erected by order of Kumara Gupta I around the year AD 400. Unlike stainless steel, however, these artifacts owe their durability not to chromium, but to their high phosphorus content, which, together with favorable local weather conditions, promotes the formation of a solid protective passivation layer of iron oxides and phosphates, rather than the non-protective, cracked rust layer that develops on most ironwork.

The corrosion resistance of iron-chromium alloys was first recognized in 1821 by the French metallurgist Pierre Berthier, who noted their resistance against attack by some acids and suggested their use in cutlery. Metallurgists of the 19th century, however, were unable to produce the combination of low carbon and high chromium found in most modern stainless steels, and the high-chromium alloys they could produce were too brittle to be practical.



In the late 1890s, Hans Goldschmidt of Germany developed an aluminothermic (thermite) process for producing carbon-free chromium. In the years 1904–1911 several researchers, particularly Leon Guillet of France, prepared alloys that would today be considered stainless steel.

Friedrich Krupp Germaniawerft built the 366-ton sailing yacht *Germania* featuring a chrome-nickel steel hull in Germany in 1908.<sup>[4]</sup> In 1911, Philip Monnartz reported on the relationship between the chromium content and corrosion resistance. On October 17, 1912, Krupp engineers Benno Strauss and Eduard Maurer patented austenitic stainless steel.<sup>[5]</sup>

Similar developments were taking place contemporaneously in the United States, where Christian Dantsizen and Frederick Becket were industrializing ferritic stainless.

In 1913, Harry Brearley of the Brown-Firth research laboratory in Sheffield, England, while seeking an erosion-resistant alloy for gun barrels, discovered and subsequently industrialized a martensitic stainless steel alloy. The discovery was announced two years later in a January 1915 newspaper article in *The New York Times*.<sup>[3]</sup> This was later marketed under the "Staybrite" brand by Firth Vickers in England and was used for the new entrance canopy for the Savoy Hotel in 1929 in London.<sup>[6]</sup>

Properties of stainless steel: High oxidation-resistance in air at ambient temperature are normally achieved with additions of a minimum of 13% (by weight)

chromium, and up to 26% is used for harsh environments.<sup>[7]</sup> The chromium forms a passivation layer of chromium(III) oxide ( $\text{Cr}_2\text{O}_3$ ) when exposed to oxygen. The layer is too thin to be visible, and the metal remains lustrous. It is impervious to water and air, protecting the metal beneath. Also, this layer quickly reforms when the surface is scratched. This phenomenon is called passivation and is seen in other metals, such as aluminium and titanium. Corrosion resistance can however be adversely affected if the component is used in a non-oxygenated environment, a typical example being underwater keel-bolts buried in timber.

When stainless steel parts such as nuts and bolts are forced together, the oxide layer can be scraped off causing the parts to weld together. When disassembled, the welded material may be torn and pitted, an effect that is known as galling. This destructive galling can be best avoided by the use of dissimilar materials, e.g. bronze to stainless steel, or even different types of stainless steels (martensitic against austenitic, etc.), when metal-to-metal wear is a concern. In addition, Nitronic alloys (trademark of Armco, Inc.) reduce the tendency to gall through selective alloying with manganese and nitrogen.

Nickel also contributes to passivation, as do other less commonly used ingredients such as molybdenum and vanadium.

There are 5 types of stainless steel. Stainless steels are also classified by their crystalline structure:

- Austenitic, or 300 series, stainless steels comprise over 70% of total stainless steel production. They contain a maximum of 0.15% carbon, a minimum of 16% chromium and sufficient nickel and/or manganese to retain an austenitic structure

at all temperatures from the cryogenic region to the melting point of the alloy. A typical composition of 18% chromium and 10% nickel, commonly known as **18/10 stainless**, is often used in flatware. Similarly, **18/0** and **18/8** are also available. Superaustenitic stainless steels, such as alloy AL-6XN and 254SMO, exhibit great resistance to chloride pitting and crevice corrosion due to high molybdenum content (>6%) and nitrogen additions, and the higher nickel content ensures better resistance to stress-corrosion cracking versus the 300 series. The higher alloy content of superaustenitic steels makes them more expensive. Other steels can offer similar performance at lower cost and are preferred in certain applications.<sup>[citation needed]</sup>

- Ferritic stainless steels are highly corrosion-resistant, but less durable than austenitic grades. They contain between 10.5% and 27% chromium and very little nickel, if any, but some types can contain lead. Most compositions include molybdenum; some, aluminium or titanium. Common ferritic grades include 18Cr-2Mo, 26Cr-1Mo, 29Cr-4Mo, and 29Cr-4Mo-2Ni. These alloys can be degraded by the presence of  $\sigma$  chromium, an intermetallic phase which can precipitate upon welding.
- Martensitic stainless steels are not as corrosion-resistant as the other two classes but are extremely strong and tough, as well as highly machineable, and can be hardened by heat treatment. Martensitic stainless steel contains chromium (12-14%), molybdenum (0.2-1%), nickel (0-<2%), and carbon (about 0.1-1%) (giving it more hardness but making the material a bit more brittle). It is quenched and magnetic.

- Precipitation-hardening martensitic stainless steels have corrosion resistance comparable to austenitic varieties, but can be precipitation hardened to even higher strengths than the other martensitic grades. The most common, 17-4PH, uses about 17% chromium and 4% nickel. There is a rising trend in defense budgets to opt for an ultra-high-strength stainless steel when possible in new projects, as it is estimated that 2% of the US GDP is spent dealing with corrosion. The Lockheed-Martin Joint Strike Fighter is the first aircraft to use a precipitation-hardenable stainless steel—Carpenter Custom 465—in its airframe.
- Duplex stainless steels have a mixed microstructure of austenite and ferrite, the aim being to produce a 50/50 mix, although in commercial alloys, the mix may be 40/60 respectively. Duplex steels have improved strength over austenitic stainless steels and also improved resistance to localised corrosion, particularly pitting, crevice corrosion and stress corrosion cracking. They are characterised by high chromium (19–28%) and molybdenum (up to 5%) and lower nickel contents than austenitic stainless steels. The most used Duplex Stainless Steel are the 2205 (22% Chromium, 5% Nickel) and 2507 (25% Chromium, 7% Nickel); the 2507 is also known as "SuperDuplex" due to its higher corrosion resistance.

Recycling and reuse: Stainless steel is 100% recyclable. In fact, an average stainless steel object is composed of about 60% recycled material, 25% originating from end-of-life products and 35% coming from manufacturing processes.<sup>[9]</sup>

Applications: Stainless steel's resistance to corrosion and staining, low maintenance, relatively low cost, and familiar luster make it an ideal base material for a host of commercial applications. There are over 150 grades of stainless steel, of which fifteen are most common. The alloy is milled into coils, sheets, plates, bars, wire, and

tubing to be used in cookware, cutlery, hardware, surgical instruments, major appliances, industrial equipment, and as an automotive and aerospace structural alloy and construction material in large buildings. Storage tanks and tankers used to transport orange juice and other food are often made of stainless steel, due to its corrosion resistance and antibacterial properties. This also influences its use in commercial kitchens and food processing plants, as it can be steam cleaned, sterilized, and does not need painting or application of other surface finishes.

Stainless steel is also used for jewellery and watches. The most common stainless steel alloy used for this is 316L. It can be re-finished by any jeweller and will not oxidize or turn black.

Some firearms incorporate stainless steel components as an alternative to blued or parkerized steel. A few more expensive revolvers like the Smith and Wesson Model 60 are milled entirely from stainless steel. This gives a high-luster finish similar in appearance to nickel plating but, unlike plating, not subject to rust when scratched.

## **CHAPTER 3**

### **METHODOLOGY**

#### **3.1 Introduction**

This chapter will discuss about methods taken order to fabricate 32 inch LCD TV bracket using stainless steel sheet..

Before start on fabrication process, design and sketching has to be done to decide which design would be the most suitable for fabrication. The design must be carefully analyze before the fabrication process can begun because it is important for the 32 inch LCD TV bracket to function and easy to fabricate. The aspect that should be considered for design the 32 inch LCD TV bracket is:-

- 3.1.1 Shape of the 32 inch LCD TV bracket: The 32 inch LCD TV bracket design must not consist sharp corner to prevent material weakness at the corner end.
- 3.1.2 Cost: The cost must not exceed beyond the budget limit and more cheaper than the example product.
- 3.1.3 32 inch LCD TV bracket availability: The design based on the existing LCD TV bracket. The existing product is strong because the material use is more expensive and heavy.
- 3.1.4 Material: The material of the 32 inch LCD TV bracket must be strong enough to hold heavy weight of the 32 inch LCD TV and can stand high energy from impact.

### 3.2 Project Flow Diagram

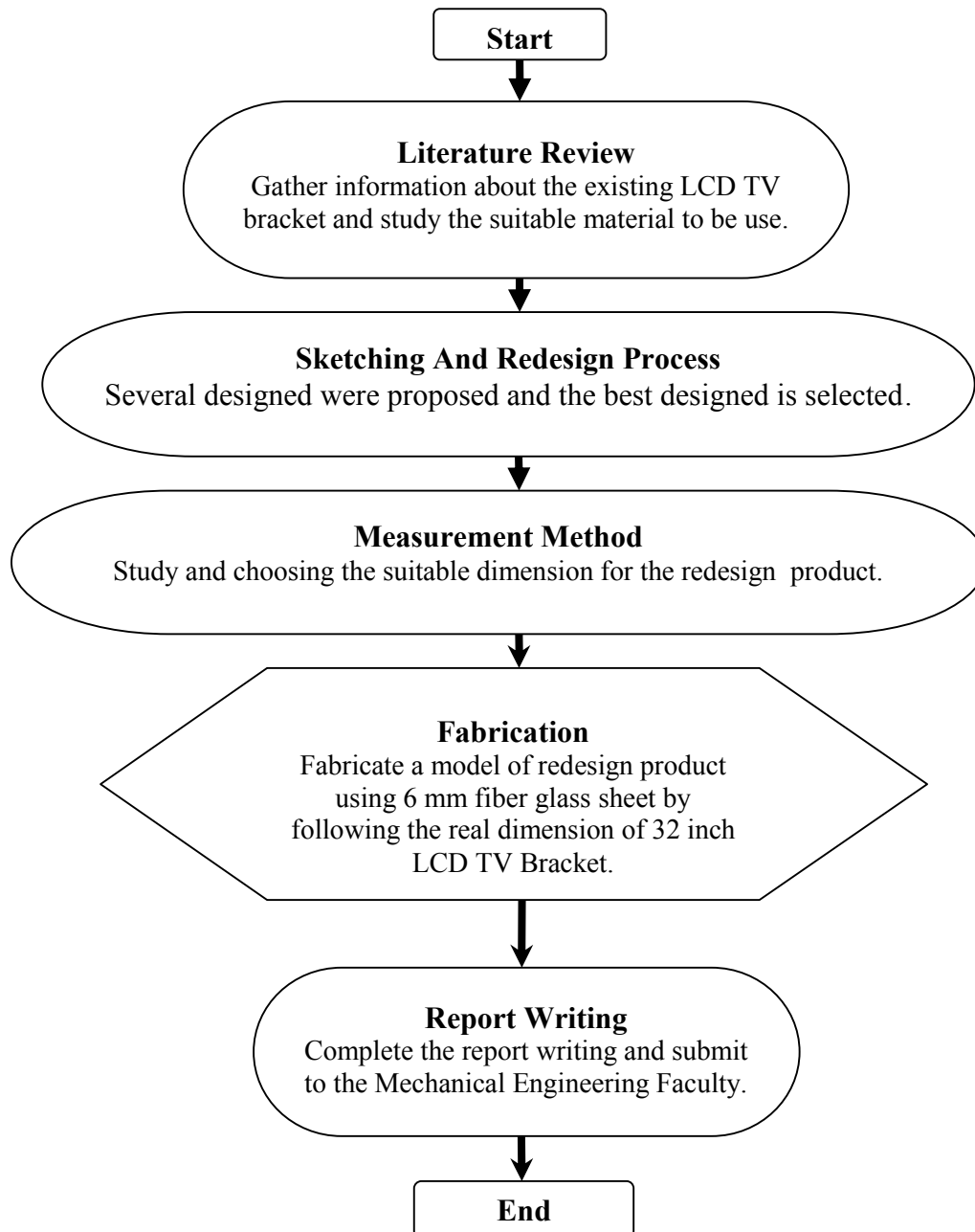



From the diagram above, the project starts with literature review and research about the title given. This consist about gather information about the existing LCD TV bracket and study the suitable material to be use. This task have been done through research on the internet, books and also by buying the existing product

After gathering all the relevant information, the project undergoes sketching and redesign process. In this step, from the knowledge gather from the review is use to make a sketch design that suitable for the project. After several design sketched, design consideration have been made and one design have been chosen. The design is transfer to solid modelling and engineering drawing using Solid Works program.

After the engineering drawing finished – include detail design and approved by supervisor, the drawing was used as a reference for the next process which is measurement method. This process is to study and choosing the suitable dimension for the redesign product.

Then, the fabrication process is started. This process is to fabricate a model of redesign product using 6 mm fiber glass sheet by following the real dimension of 32 inch LCD TV Bracket. Because the real product cannot be made, a model is made by using fiber glass sheet by only using hand tools that is hand saw and steel ruler.

After all the process mentioned above is done, all the material for report writing is gathered. The report writing process will be guided by the UMP final year project report writing. This process also included the presentation slide making for the project.

This project ended after the submission of the report and the slide presentation has been present.

Project Activities	Week(s)													
	1	2	3	4	5	6	7	8	9	10	11	12	13	14
Title Selection			■	■	■									
Literature Review				■	■	■	■	■						
Sketching And Redesign Process							■	■	■	■				
Measurement Method								■	■	■	■	■	■	
Fabrication									■	■	■	■	■	■
Report writing							■	■	■	■	■	■	■	■

Table 1 : Gantt chart

### 3.3 Project Planning

This project is begun with choosing the title given by supervisor. By gathering some information about the selection title, it takes about 3 weeks to chose the best title.

After made a research and search for information via internet, books, supervisor, by buying the example product and other relevant academic material related to the title, this literature review takes about 4 weeks to be done. But the findings of information did not stop there. It continues along the way of this project because the knowledge is so many to learn.

At the same 2 weeks started looking information for literature review, the next process is started. The sketching and redesign process of the LCD TV bracket for 32 inch. Sketching and redesign process takes 4 weeks to chose the best design before going to the next step.

Then, when the selected design is ready by transfer it to the Solid Works drawing, measurement process is done. But only a model of the redesign product is made.

The fabrication process takes more time about 5 weeks because a model is made, but not the real redesign product of 32 inc LCD TV bracket. It takes more time because the process of cutting the material use, that is fiber glass is using hand tools that is steel ruler and hand saw.

The report writing process is started from weeks 7 until the report writing finish and submitted to the supervisor for checking and then sent to the FKM faculty for further step.

## **CHAPTER 4**

### **RESULT AND DISCUSSION**

#### **4.1 Introduction**

This chapter will cover about all the steps after all information have done, yhe result that were get from this project and also the problems which appear in progress of the project before, during and after the project. Problems that will be discussed here are the prominent problem encountered in every stage in the progress project.

## **4.2 Design Specification**

The design must consider it can endure this below specification:

- Thickness of sheet stainless steel use = 1.5 mm below
- Specific for LCD TV 32 inch only
- Use less tools than the example product
- Material use is more cheaper than the example product

## **4.3 Design Selection**

The design is separate into three phases. This is, first sketched as many propose design can be produce. Then select one of it and do its detail drawing and the engineering drawing, and the last phases are design back using Solid Works program.

### **4.3.1 Propose Design**

From many design are sketch, only five concept designs have been choose to be considered.

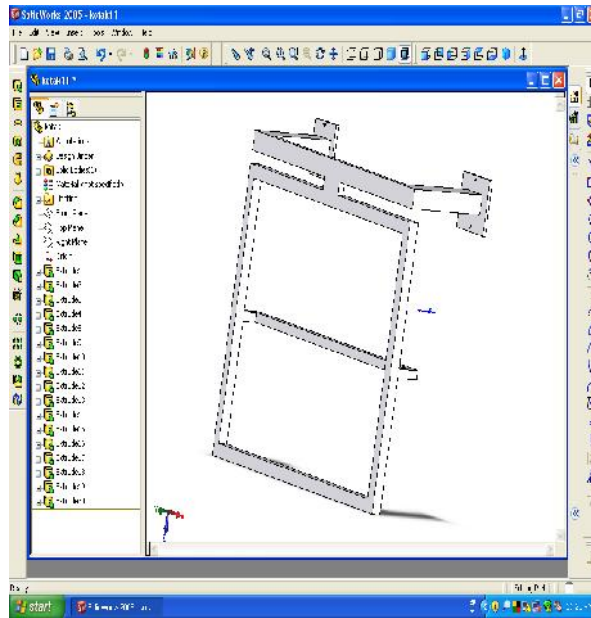

Figure 8 : LCD TV wall mount

Table 2 : Advantages and disadvantages of LCD TV wall mount

ADVANTAGES	DISADVANTAGES
<ul style="list-style-type: none"> <li>• Light and use less tools.</li> </ul>	<ul style="list-style-type: none"> <li>• The cost of fabrication is expensive.</li> <li>• Not easy to assemble.</li> </ul>

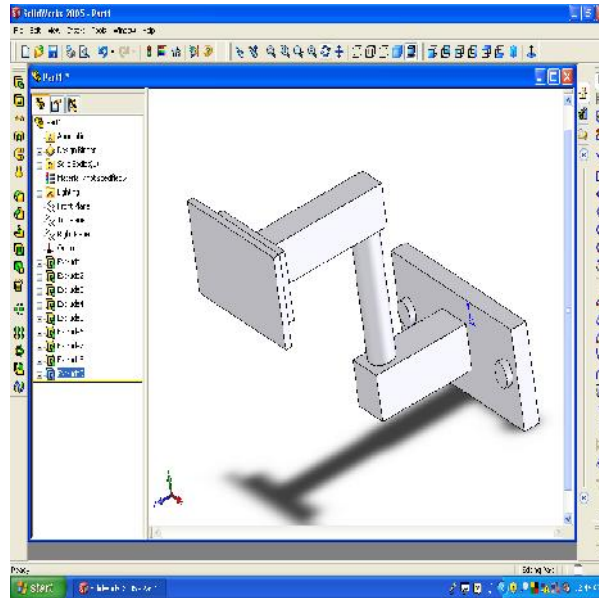

Figure 9 : LCD TV simple wall mount

Table 3 : Advantages and disadvantages of LCD TV simple wall mount

ADVANTAGES	DISADVANTAGES
<ul style="list-style-type: none"> <li>• Easy to assemble and mounting the LCD TV to the wall.</li> <li>• The size is ergonomic and friendly use.</li> </ul>	<ul style="list-style-type: none"> <li>• Heavy and the process of fabrication is expensive.</li> </ul>

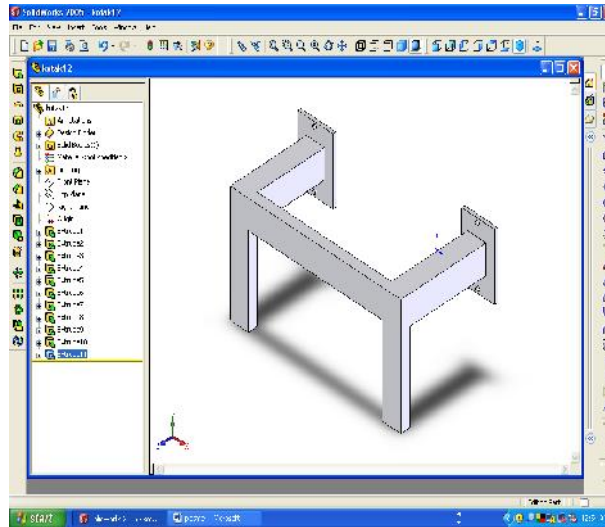

Figure 10 : LCD TV easy bracket

Table 4 : Advantages and disadvantages of LCD TV easy bracket

ADVANTAGES	DISADVANTAGES
<ul style="list-style-type: none"> <li>• Light and use less tools.</li> <li>• Easy to assemble and mount to the wall.</li> </ul>	<ul style="list-style-type: none"> <li>• The cost of fabrication is expensive.</li> </ul>



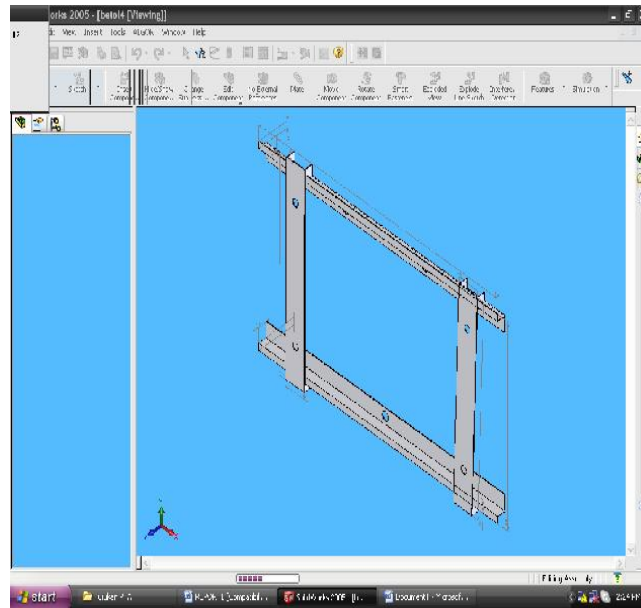

Figure 11 : LCD TV bracket

Table 5 : Advantages and disadvantages of LCD TV bracket

ADVANTAGES	DISADVANTAGES
<ul style="list-style-type: none"> <li>• Light and use less tools.</li> <li>• Low cost of fabrication.</li> <li>• Easy to assemble and mount to the wall.</li> </ul>	<ul style="list-style-type: none"> <li>• Can use only for 32 inch LCD TV.</li> </ul>

#### 4.4 Pugh Selection Method

Table 5 : Pugh Selection Method

	CONCEPTS			
Selection Criteria	A	B	C	D
Low cost	-	-	-	+
Use less tools	+	+	+	+
Light in weight	+	-	+	+
Easy to mount to the wall	-	+	+	+
Sum + 's	2	2	3	4
Sum - 's	2	2	1	0
Net score	0	0	2	4
Rank	3	3	2	1

The conclusion from the concept scoring is the Concept D is chosen as the best selection product. This is because it has the higher (+) with no (-). It is also the most light in weight, less tools use, low cost and easy to mount to the wall than other concept. The different criteria of every concept also influence the product selection. Not every product is good and high in quality for manufacturer.

## 4.5 Brainstorming

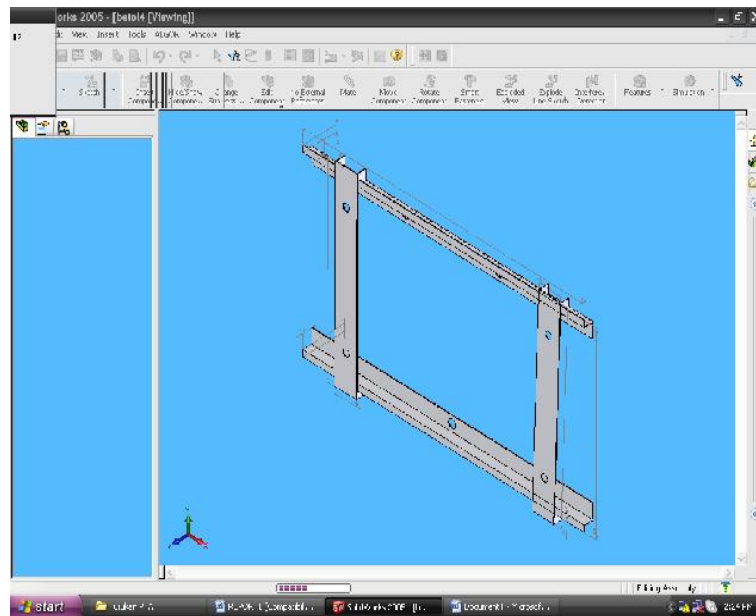

Figure 12 : LCD TV bracket

The advantage of this design is it can easily mount to the wall and easy to assemble each parts of the bracket. It is using 3 set of lag bolt ,lag bolt washer and concrete anchor to mount the bracket to the wall. To assembly each parts of the bracket to the LCD TV, it use 4 set of bolt and washer. It does not use all the tools supply from

the example bracket. The panel thickness is 1.00 mm which is lower than the example bracket that is lower than 1.5 mm. The material use is stainless steel that is more light and cheaper than cold steel. Even though the example product can be tilt from 0 to 15 degree, this new bracket is only for static vertical view to the wall. It is mount to the wall more secure and tightly for 32 inch LCD TV only. To mount the bracket to the wall also very easy because you don't need to hire a professional to mount it. You can do it yourself with your family help.

#### **4.6 Raw Material & Apparatus**

The material and apparatus use in this project is:-

- a) Stainless steel sheet – Stainless steel sheet with 1.0 thickness used as a main material.
- b) Bolt – To secure and assemble the LCD TV bracket with lock washer and washer.
  - An externally threaded fastener designed for insertion through holes in assembled parts and is normally intended to be tightened or released by torquing a nut.
- c) Washer and Lock Washer – Use to distributed the load of a threaded fastener, spacer, spring, wear pad, preload indicating device, and locking device.
  - Use to tighten and secure parts assembly with bolt
  - To avoid wear and preventing galvanic corrosion the bracket.
- d) Lag Bolt – To securely fastening heavy timbers to one another, or fasten wood to machinery or concrete.
  - To secure the LCD TV bracket to the wall by joining with concrete anchor and lag bolt washer.
- e) Lag Bolt Washer – To tighten the lag bolt to the bracket and wall

- To prevent wear and galvanic corrosion to the bracket.
- f) Concrete Anchor – To attach objects or structures to concrete.
  - To connect the bracket to the wall with lag bolt and lag bolt washer.
- h) Measuring tape and venire caliper – Use to measure the material.

#### **4.7 Fabrication Process**

The fabrication process begun after design phase using Solid Work software is finished. The designing process is significant to determine the actual dimension for fabrication. There is several methods that are involve in the making of the 32 Inch LCD TV Bracket such as:-

- a) Measuring: Measuring the material using measuring tape and venire caliper into dimension needed.
- b) Cutting: Cutting using CNC plasma cutting machine according to dimension needed and cutting the specimen to the shape that needed.
- c) Bending: Bending each parts to the shape needed using bending machine.
- d) Fastening: Fasten the screw and nut to join each parts of the bracket.
- e) Drilling: Drill using hand drill to make holes.

#### 4.8 Procedure Setup

Before the fabrication can begin, the process procedure must determine and carefully plan to ensure fabrication process goes smoothly. There are 2 phase of the process. First is using the punch machine to cut the material and then using bending machine to shape the material. The material have to be prepared before started on fabrication process. First, measure the material to the real dimension needed. Cut the material to the dimension needed using the punch machine. Then, use the bending machine to 90 degree to shape the material. To drill the holes, use the hand drill with the size needed. The personal protective equipment must be ware all the time to avoid irritation and side effect during the fabrication process. The working area must be equipped with adequate ventilation.

#### 4.9 Steps of Fabrication Procedure

- a) Step 1: After all the procedure setup has been done the fabrication process can be started.
- b) Step 2: The material is cut to the dimension needed using CNC plasma cutting machine.
- c) Step 3: Each parts is bend to 90 degree to make the shape needed using bending machine.
- d) Step 4: After getting the parts needed, drill the holes using hand drill following the size of the screw and bolt used.
- e) Step 5: Joint each parts using screw and nut.
- f) Step 6: Then, the finishing process is to make sure the bracket is secure and ready to be use.

#### 4.10 Manufacturing Cost:-

Example product cost : RM160.00

Redesign 32 inch LCD TV Bracket Assume:-

a) Material Cost

Items	Quantity	Price
Stainless Steel Sheet Metal	600mm x 500mm (thickness 1.0mm)	RM70.00

b) Overhead Cost

Material	Quantity	Price
Bolt and Washer	RM0.50 x 4	RM8.00
Lag Bolt and Lag Bolt Washer	RM1.00 x 3	RM3.00
Concrete Anchor	RM1.00 X 3	RM3.00
	<b>Total</b>	<b>RM14.00</b>

$$\begin{aligned}
 \text{Total Cost} &= \text{Material Cost} + \text{Overhead Cost} \\
 &= \text{RM70.00} + \text{RM14.00} \\
 &= \mathbf{\text{RM84.00}}
 \end{aligned}$$

$$\begin{aligned}
 \text{Save Cost} &= \text{Example Product} - \text{Assume Redesign Product} \\
 &= \text{RM160.00} - \text{RM84.00} \\
 &= \mathbf{\text{RM76.00}}
 \end{aligned}$$

#### 4.11 Analysis About The Material Use:

This table show why stainless steel is choose as the best material to be use for making the 32 inch LCD TV bracket:

Material/ Characteristic	Stainless Steel	Aluminium	Steel
Strength	/	X	/
Hardness	/	X	/
Cost	/	/	X
Resistance to corrosion	/	/	/
Easily available	/	/	X
Low density	/	/	X

Table 7 : Characteristic of three different material

X : No

/ : Yes

The table show that stainless steel is the most suitable material should be use. It has good characteristic than aluminium and steel. Stainless steel is good in strength, hardness and low density. It is also low in cost even though aluminium is more cheap, but it is cheaper than steel and affordable to buy. It is also resistance to corrosion so the 32 inch LCD TV bracket can last long. Futher more, it is easily available.



#### 4.12 Analysis About The Product:-

a)Material That Uses – Stainless Steel Sheet (1.00mm)

b)The Useful of the LCD TV Bracket ( Assume ) :-

After the researches on the market, the LCD TV bracket also known as LCD TV wall mount. It is widely use nowadays because there are many types and size of LCD TV are made and produce. But the existing LCD TV wall mount is quite expensive and heavy. User might think twice weather want to hang their LCD TV or just put it down with a stand. This new redesign of 32 inch LCD TV bracket is more light with low cost. User also can assemble the bracket to the wall easily and more secure. It is also use less tools to assemble and it is also ergonomic in style. It is made to mount the 32 LCD TV inch only because user mostly by the LCD TV with that size.

c)Advantages :-

- a) Easy to mount to the wall.
- b) The product is looking simple.
- c) It uses less tools.
- d) It is light in weight.
- e) The cost of develop the product is not expensive and suitable for every rank of community to get it.

d)Disadvantages :-

- a) The shape is not friendly user.
- b) Can mount only 32 inch LCD TV

## **CHAPTER 5**

### **CONCLUSION**

#### **5.1 Summary of Project**

This project generally related to fabrication and redesign of 32 inch LCD TV bracket. This project explains the process and procedure for fabricate and redesign the 32 inch LCD TV bracket.

The fabrication of the LCD TV bracket is follow the example product that sells around us. The example product is provided with safety and follow the secure and specification of international design. This new redesign bracket is proven can be use safely because it is perform according to the existing bracket sold.

## **5.2 Future Work**

Future planning to improve the fabrication and redesign process to create more efficient design and shape of LCD TV bracket that is more light and cheap. By using more suitable material and reduce the thickness of the bracket, it will be more easier to mount to the wall and easier to join each parts. To lesson the use of tools, creating a new design without using any tools might be performed.

## **5.3 Conclusion**

The project is managed to succeed in the time given and also successfully reaches the target and objective of the project. The process is follow the gantt chart, it is done successfully as the target. If the bracket is more light and cheaper, people can afford to use this bracket for their LCD TV at home or any where.

## APPENDIX A

### 3-D Engineering Drawing

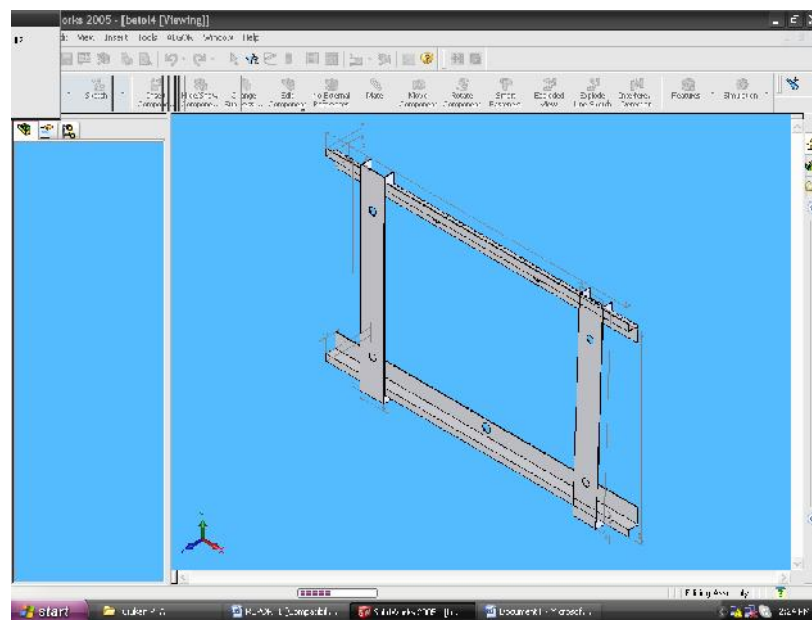

Picture 1 : 32 inch LCD TV bracket

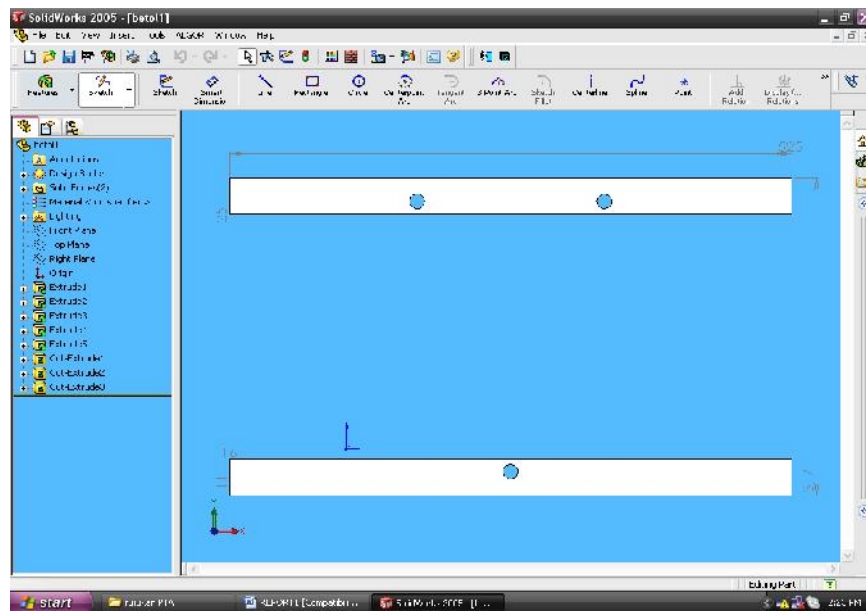

Picture 2 : Parts mount to the wall

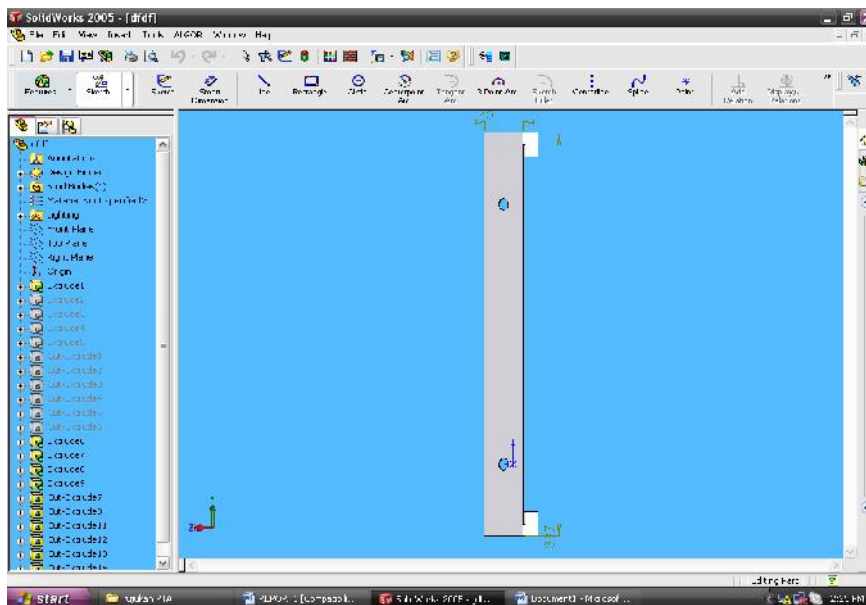

Picture 3 : Parts mount to the LCD TV

## APPENDIX B

Project Activities	Week(s)													
	1	2	3	4	5	6	7	8	9	10	11	12	13	14
Title Selection			■	■	■	■								
Literature Review					■	■	■	■	■					
Sketching And Redesign Process							■	■	■	■	■			
Measurement Method								■	■	■	■	■	■	■
Fabrication									■	■	■	■	■	■
Report writing							■	■	■	■	■	■	■	■

Table 8 : Gantt chart

## APPENDIX C

### Materials & Apparatus



Picture 4 : A model of 32 inch LCD TV bracket



Picture 5 : Lag bolt, concrete anchor and lag washer



Picture 6 : Bolt and washer



## APPENDIX D

### Machine Use



Picture 7 : Front side of bending machine



Picture 8 : Back side of bending machine



Picture 9 : CNC plasma cutting machine



Picture 10 : Shearing and punch machine

**REFERENCES**

1. Kalpakjian, S., Schmid, S.R, and Musa, H. (2000) Manufacturing Engineering And Technology.
2. Haik, Y. (2003) Engineering Design Process. USA: Thomson Brooks/Cole.
3. <http://www.lcdtv.mhnt.com> dated on 20 April 2009.
4. <http://www.stainlesssteel.com> dated on 22 April 2009.