

Cycle-to-Cycle Variations of a Diesel Engine Operating with Palm Biodiesel

M. H. Yasin¹, R. Mamat¹, A. A. Abdullah¹, N. R. Abdullah², M.L. Wyszynski³

¹Faculty of Mechanical Engineering, Universiti Malaysia Pahang, Malaysia

²Faculty of Mechanical Engineering, Universiti Teknologi MARA, Malaysia

³University of Birmingham, United Kingdom

Abstract

Biodiesel is one of biodegradable and renewable fuel which is originated from vegetable oil or animal fats. Different fuel properties of biodiesel produce different combustion characteristics which slightly differ to mineral diesel. Combustion studies on palm-biodiesel and mineral diesel were conducted using a multi-cylinder diesel engine. Cycle-to-cycle variations of peak cylinder pressure and mean indicated pressure of the test fuels were determined for the combustion characteristics of diesel engine. In-cylinder pressure data for the 200 consecutive cycles were determined using a Kistler pressure transducer and recorded into a combustion analyzer. Three different engine loads: 20%, 40% and 60% were selected in this study with a constant engine speed of 2500 rpm. The results show that at lower load, in-cylinder pressure variations for palm biodiesel were lower compared to mineral diesel. However at medium and high loads, palm biodiesel has dominated the peak cylinder variations.

Keyword: cycle-to-cycle variations, biodiesel, combustion, diesel engine

Introduction

Biodiesel can be considered as an alternative fuel for diesel engines. Biodiesel chemically is described as fatty acid methyl or ethyl esters from vegetable oils or animal fats [1, 2]. Biodiesel is renewable, biodegradable and oxygenated fuel [3]. Although many researches pointed out that it might help to reduce greenhouse gas emissions, promote sustainable rural development, and improve income distribution, there still exist some drawbacks in using biodiesel. There are initiatives to replace gasoline and diesel fuel due to the impact of fossil fuel crisis, hike in oil prices and stringent emission norms [4]. There is no engine modification of any diesel engine part needed when operating with biodiesel [5, 6]. From the studies, researchers have concluded that biodiesel can reduce the percentage of CO, CO₂, HC, PM and SO_x but slightly higher in brake specific fuel consumption (bsfc) and NO_x emissions with the same amount of air and fuel is injected through the cylinder [7-11]. While in some research, there is a similar performance between ultra-low sulfur diesel (ULSD) and RME when compared in similar relative equivalence ratio [12].

Biodiesel consists certain properties such as density, viscosity, cetane number, low heating value, cloud and pour point with different characteristics of distillation [13, 14]. Physical and chemical properties of biodiesel are slightly different from those of original diesel [15-18]. Differences can be seen on the fuel atomization, evaporation and emission formation processes [11]. Biodiesel also known has higher density and viscosity compared to

mineral diesel. In few cases, biodiesel has been diluted with mineral diesel with different proportions to reduce the density and viscosity when operating with diesel engines [8, 19, 20]. However, many researchers have found out that the ignition delay became shorter when the mixing ratio of biodiesel increases because the cetane number of biodiesel is greater than that of conventional diesel. Liaquat et al were studied of the neat jathropa biodiesel (JME) and blends with standard diesel. The result shows the decreasing of calorific value of fuel in term of engine power reduction and increasing in fuel consumption. However, the formation level of NO_x become higher due to affect in ignition delay and increasing amount of fuel in rapid combustion and the combustion temperature level, [21].

The measurement and the analysis of cyclic variation in spark ignition engines have been made by many researchers around world [22-26]. Most of the studies are interest on reducing the instability of SI engines especially engine knock. Recently, the cyclic variations analysis have been done in diesel engines due to different fuel used on standard diesel engine such as alcohol and liquefied natural gas (LNG) [27-29]. There were several studies related to cycle-to-cycle variation of pressure on both spark ignition and diesel engine operating on standard fuel of diesel, biodiesel, biofuel such as methanol and ethanol and gasoline [30-32]. The variation of cycle-to-cycle were developed from the combustion when engine operating conditions achieve the fundamental limits such as lean flammability [33, 34]. Cyclic variations in the combustion process are caused by variations in mixture motion within the cylinder, variations in the amount of air and fuel fed to the cylinder each cycle, and variations in the mixing of fresh mixture and residual gases within the cylinder each cycle [35] Higher combustion variations due to higher cyclic variations may reduce the total power, engine durability.

In this paper, palm-biodiesel denoted as B100 and mineral diesel as a baseline fuel were tested in same diesel engine under same operating condition with constant speed of 2500 rpm at low, medium and high load of engine. In cycle-to-cycle variation analysis, the combustion cycles for the test were set and recorded at 200 consecutive cycles. Result of this study were discussed on the in-cylinder pressure variations along 200 consecutive cycle based on the statistical analysis (minimum, median, standard deviation, maximum) and the study of the cycle-to-cycle variations in mean indicated pressure (MIP) for the test fuels.

Methodology

A four-stroke, four-cylinder Mitsubishi 4D68 diesel engine was used for the experimental work. The engine is an indirect injection (IDI), water-cooled and attached with a diaphragm exhaust gas recirculation (EGR) piping system. Details for the engine are designated in Table 1 . The engine used in the study was coupled with a connecting shaft to a 150 kW eddy-current type water-cooled Dynalec dynamometer model ECB-200F SR 617 for the engine loading. First cylinder of four engine cylinders was mounted with a Kistler 6041A water-cooled ThermoComp in-cylinder pressure transducer by replacing the current glow plug. This device was connected to the charge module, DAQP-Charge B with a Kistler cable model 1921A to convert the analogue signal into the digital signal.

Table 1. Specification of test engine.

Engine Specification	Details
Number of cylinders	4 in-line
Combustion chamber	Swirl chamber
Total displacement cm	1.998 cc (121.925 cu. in)
Cylinder bore mm x Piston stroke mm	82.7 x 93
Bore/stroke ratio	0.89
Compression ratio	22.4:1
Maximum Power	(64.9 kW) @ 4500 rpm
Maximum Torque	177.0 Nm @ 2500 rpm

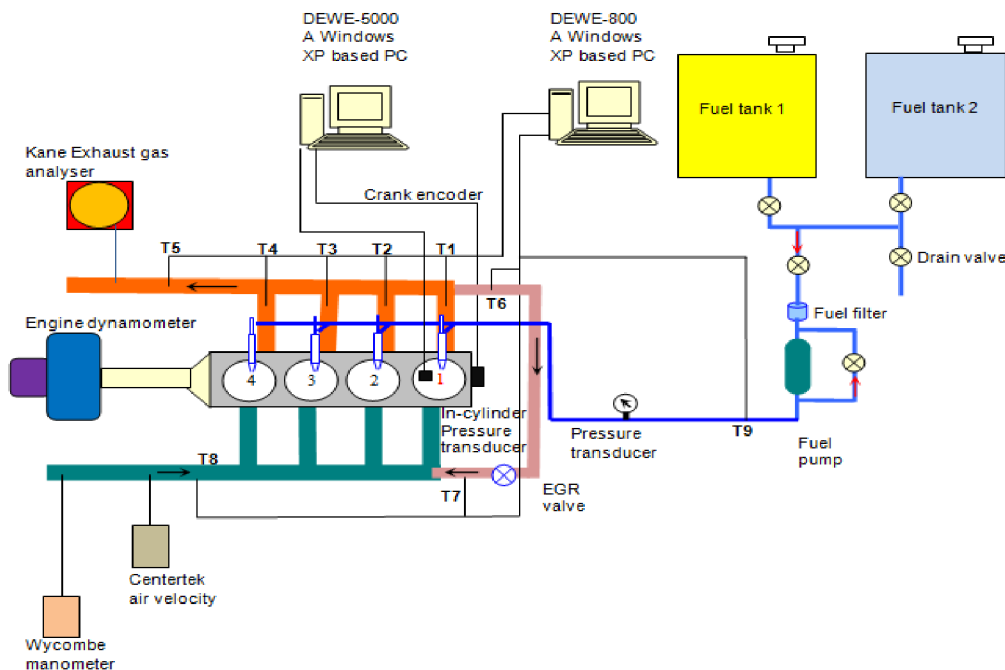

Figure 1. Schematic diagram of a Mitsubishi 4D68 diesel engine system.

A Kistler CAM crank angle encoder model 2613B1 was mounted in alignment to the crank shaft pulley at the engine side and connected to the Kistler signal conditioner model 2613 B2. This setting was used to determine the crankshaft position within the combustion period and the piston continuous movements from the top dead center (TDC) to the bottom dead center (BDC). Both Kistler pressure transducer and crank angle encoder were producing the signals that been recorded and translated using a Dewetron data acquisition (DAQ) system with a Orion 1624 DAQ card installed in a Windows XP based PC, DEW-5000 combustion analyser. The combustion data for the test fuels were recorded for 200 consecutive cycles so that the averaged results can be computed. There were 19 K-type thermocouples were mounted to the engine to measure the temperature of the engine include all the exhaust extractors. Those temperature data were monitored and recorded using a Dewetron DAQ system installed on a DEWE-800, Windows XP based PC.

High end combustion analysis software named DEWECa from Dewetron Inc. was used to provide the off-line steady state analysis regarding to the in-cylinder pressure and crank angle degree (CAD). This software is capable to compute the indicated power, indicated mean effective pressure (IMEP), mass fraction burn (MFB), rate of heat release (RoHR) and brake thermal efficiency (BTE). A Kane gas analyzer was used to measure the engine exhaust emission and was saved into Excel file format. The sample of exhaust gases was taken at 0.5 m downstream of the exhaust extractor. A Dynalec controller was used to control the engine speed for the constant speed and engine loads. Table 2 listed the engine test condition for the study while in Table 3 summarized the fuel properties.

Table 2. Test condition.

Engine Parameter	Details
Engine speed, n	2500 rpm
Fuel temperature, Tf	30°C
Naturally aspirated air temperature, Tba	35°C
Mode of EGR	OFF

Table 3. Fuel properties.

Description	Testing Method (ASTM)	Mineral diesel	B100
Density @ 20 °C g/cm ³	D287	0.837	0.878
Viscosity @40 °C mm ² /s	D445	4.237	5.68
Cetane number	D613	71.6	
Flash Point (°C)	D93	70	180
Acid Number	D3339	0.24	0.3
Net heat of combustion (MJ/kg)	D240	49.962	39.916

In this experimental study, B100 originated from palm oil and mineral diesel as a baseline fuel was used as test fuels. Combustion analysis regarding to the peak cylinder pressure and mean indicated pressure (MIP) were determined for the base of the study; to analyze the cycle-to-cycle combustion variations for different fuels at a constant engine speed with three different engine loads namely; 20%, 40% and 60%.

Results and Discussion

A Mitsubishi diesel engine was used to test the test fuels; B100 (palm biodiesel) and mineral diesel as a baseline fuel with measuring the in-cylinder pressure corresponding to the crank angle degree (CAD) at 200 consecutive cycles. The experimental study for the test fuels was performed at a constant engine speed of 2500 rpm with three different engine loads namely; 20%, 40% and 60% for the combustion cyclic variation in the measured cylinder. Comparison can be made with the test fuels upon the same condition due to oxygen contents and lower heat value of combustion differences. The baseline fuel was conducted first with the diesel engine to determine the standard values for the performance and combustion then

followed by B100, and repeated again with the mineral diesel. The same procedure has been repeated within the same engine operating condition to ensure the result accuracies. The stainless steel fuel line has been cleaned with the engine was left operated averaged 20 minutes to stabilize the engine condition for every fuel change.

The in-cylinder pressure measurement recording for the test fuels were determined for the 200 cycles with a sampling rate that corresponds to 1° CA. Indicated cylinder pressure has been averaged by taking the number of 200 combustion cycles. The measured signals from a pressure transducer that simultaneously recorded, indicates the top dead center (TDC) position for each combustion cycle. The position of TDC can be accurately determined for each combustion cycle. The calculation of the accurate constant engine speed for each combustion cycle with denying the friction factor can consider the TDC position of any two following cycles.

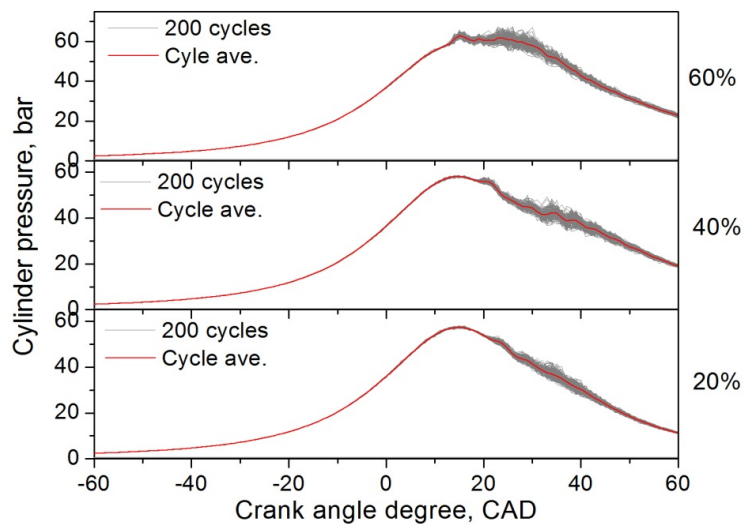

Figure 2. Cylinder pressure for B100 at three different engine loads; 20%, 40% and 60%.

Figure 2 and 3 show the peak cylinder variations with different fuels; namely mineral diesel and B100 for 200 consecutive combustion cycles at different engine loads of 20%, 40% and 60% with the constant engine speed of 2500 rpm. It shows that at low load, the mineral diesel has dominated the overall peak cylinder pressure but at medium and high load, B100 has surpassed the mineral diesel. It is also noted that the sudden change in the cylinder pressure during the combustion process has affected the rate of heat release (RoHR) and rate of pressure rise (RoPR) of the test fuels. Maximum, mean and minimum values for the 200 consecutive cycles were statistically computed using the peak cylinder pressure of the test fuels to differentiate the change at different engine loads.

Selected minimum, mean, standard deviation and maximum values of peak cylinder pressure for the test fuels; namely mineral diesel and B100 corresponding to the crank angle degree (CAD) were illustrated in Figure 4. These values covered at 200 consecutive cycles with three engine loads of 20%, 40% and 60% operated at the constant engine speed of 2500

rpm. It is clearly noted from the figure that those single peak cylinder pressure that occurred from the combustion at top dead center (TDC) after the fuel has been injected in the combustion chamber. The air/fuel ratio and different types of test fuels used in the diesel engine are among the main parameters that influences the magnitude of the maximum in-cylinder pressure cyclic variations.

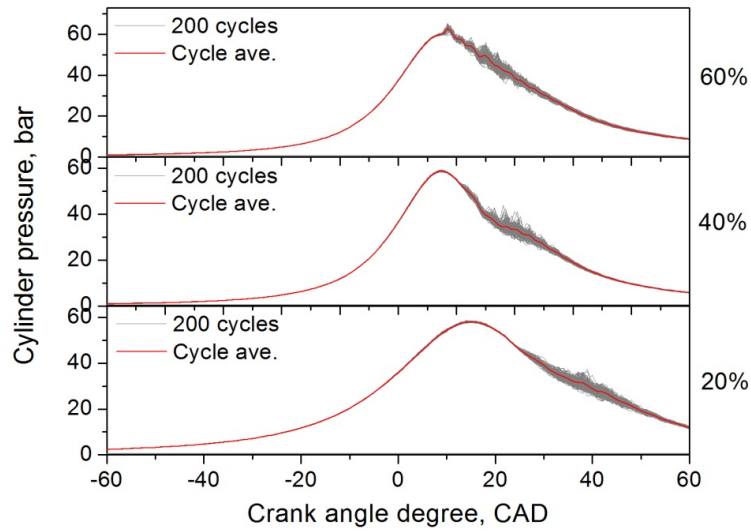

Figure 3. Cylinder pressure for mineral diesel at three different loads; 20%, 40% & 60%

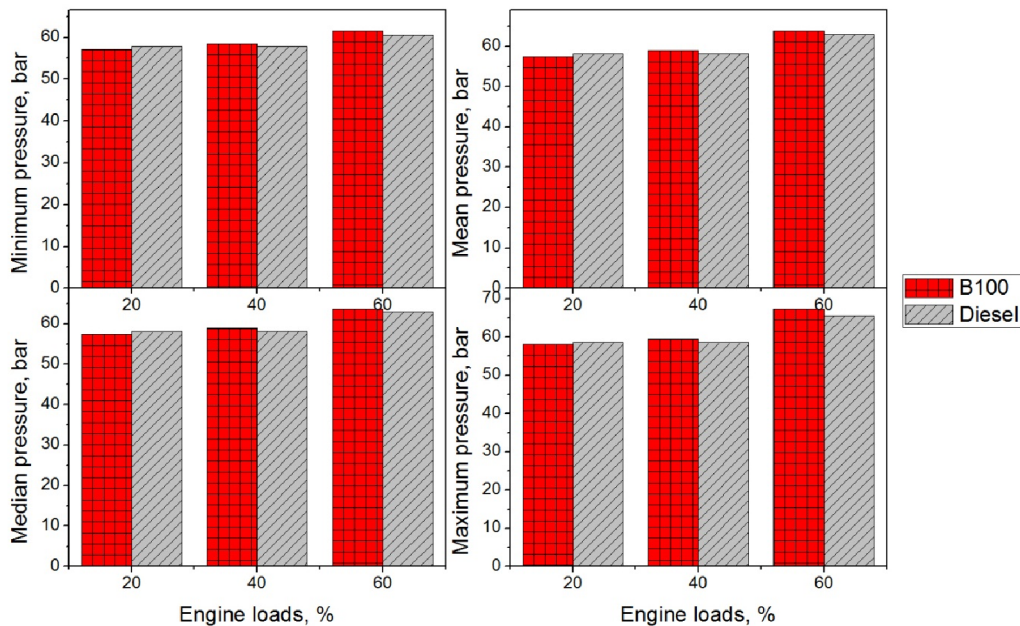

Figure 4. Cylinder pressure statistical analysis for B100 and mineral diesel at three different engine loads; 20%, 40% and 60%

Conclusion

There are convincing reasons that motivate the experimental work on the combustion cyclic variation studies operating with biodiesel for diesel engine; specifically (1) determine and optimize the lean combustion efficiency with superior engine performance, (2) associate the diesel engine combustion cycles with the numbers of emission produced within the combustion period operating different types of fuel. This paper mainly focused on the combustion cyclic variations for peak cylinder pressure and various MIP distribution patterns with different test fuels; namely mineral diesel and B100 corresponding to number of cycles. Different combustion cyclic variations for mineral diesel and B100 are observed and mostly influenced by physicochemical properties differences include viscosity and density. Different in-cylinder pressure patterns analysis in the study is important to review because it could leads for improving the leaner fuel conversion efficiency and can be adapted for the emission strategies to control the emission of NO_x, CO₂, CO and unburned hydrocarbons (UHCs).

Acknowledgements

The authors would like to thank the Faculty of Mechanical Engineering in Universiti Malaysia Pahang (UMP) and Universiti Malaysia Pahang for financial support under RDU110332.

References

- [1] Gerpen JV, Peterson C, Goering C, ... Biodiesel: an alternative fuel for compression ignition engines: asae.frymulti.com; 2007.
- [2] Ayhan D. Importance of biodiesel as transportation fuel. *Energy Policy*. 2007;35:4661-70.
- [3] Ayhan D. Competitive liquid biofuels from biomass. *Applied Energy*. 2011;88:17-28.
- [4] Bozbas K. Biodiesel as an Alternative Motor Fuel: Production and Policies in the European Union. *Renewable and Sustainable Energy Reviews* 12 (2008) 542-552 2008.
- [5] Hossain AK, Davies PA. Plant oils as fuels for compression ignition engines: A technical review and life-cycle analysis. *Renewable Energy*. 2010;35:1-13.
- [6] Ayhan D. Progress and recent trends in biodiesel fuels. *Energy Conversion and Management*. 2009;50:14-34.
- [7] Fang T, Coverdill RE, Lee C-fF, White RA. Air–fuel mixing and combustion in a small-bore direct injection optically accessible diesel engine using a retarded single injection strategy. *Fuel*. 2009;88:2074-82.
- [8] Y. V. Hanumantha Rao RSV, V. S. Hariharan, A. V. Sitarama Raju, P. Nageswara Redd. Use of Jatropha Oil Methyl Ester and Its Blends as an Alternative Fuel in Diesel Engine. *J of the Braz Soc of Mech Sci & Eng*. 2009;XXXI:253-60.
- [9] McCarthy P, Rasul MG, Moazzem S. Comparison of the performance and emissions of different biodiesel blends against petroleum diesel. *International Journal of Low-Carbon Technologies*. 2011.
- [10] Um S, Park SW. Modeling effect of the biodiesel mixing ratio on combustion and emission characteristics using a reduced mechanism of methyl butanoate. *Fuel*. 2010;89:1415-21.
- [11] An H, Yang WM, Maghbouli A, Chou SK, Chua KJ. Detailed physical properties prediction of pure methyl esters for biodiesel combustion modeling. *Applied Energy*. 2013;102:647-56.

- [12] Senatore A CM, Rocco V, Prati MV. . A comparative analysis of the combustion process in D.I. Diesel engine fueled with biodiesel and diesel fuel. SAE paper. 2000;2000-01-0691.
- [13] Demirbas A. Characterization of Biodiesel Fuels. *Energy Sources, Part A: Recovery, Utilization, and Environmental Effects*. 2009;31:889-96.
- [14] Atabani AE, Silitonga AS, Badruddin IA, Mahlia TMI, Masjuki HH, Mekhilef S. A comprehensive review on biodiesel as an alternative energy resource and its characteristics. *Renewable and Sustainable Energy Reviews*. 2012;16:2070-93.
- [15] Zhang T, Chao Y, Liu N, Thompson J, Garcia M, He BB, et al. Case Study of Biodiesel-Diesel Blends as a Fuel in Marine Environment. *Advances in Chemical Engineering and Science*. 2011;1:65-71.
- [16] Shahabuddin M, Liaquat A, Masjuki H, Kalam M, Mofijur M. Ignition delay, combustion and emission characteristics of diesel engine fueled with biodiesel. *Renewable and Sustainable Energy Reviews*. 2013;21:623-32.
- [17] Tarabet L, Loubar K, Lounici MS, Hanchi S, Tazerout M. Eucalyptus Biodiesel as an Alternative to Diesel Fuel: Preparation and Tests on DI Diesel Engine. *BioMed Research International*. 2012;2012.
- [18] Marchetti JM. A summary of the available technologies for biodiesel production based on a comparison of different feedstock's properties. *Process Safety and Environmental Protection*. 2012;90:157-63.
- [19] Ceviz MA, Koncuk F, Küçük Ö, Gören AC, Yüksel F. Analysis of Combustion Stability and Its Relation to Performance Characteristics in a Compression Ignition Engine Fueled with Diesel-biodiesel Blends. *Energy Sources, Part A: Recovery, Utilization, and Environmental Effects*. 2011;33:990-1003.
- [20] Chauhan BS, Kumar N, Cho HM. A study on the performance and emission of a diesel engine fueled with *Jatropha* biodiesel oil and its blends. *Energy*. 2012;37:616-22.
- [21] Liaquat AM, Masjuki HH, Kalam MA, Varman M, Hazrat MA, Shahabuddin M, et al. Application of blend fuels in a diesel engine. *Energy Procedia*. 2012;14:1124-33.
- [22] Litak G, Kaminski T, Czarnigowski J, Zukowski D, Wendeker M. Cycle-to-cycle Oscillations of Heat Release in a Spark Ignition Engine. *Meccanica* (2007) 42:423-433. 2007.
- [23] Aleiferis PG, Taylor AMKP, Whitelaw JH, Ishii K, Urata Y. Cyclic Variations of Initial Flame Kernel Growth in a Honda VTEC-E Lean-Burn Spark-Ignition Engine. SAE Technical Paper 2000-01-1207. 2000.
- [24] Naitoh K, Kaneko Y, Iwata K. SI-Engine Design Concept for Reducing Cyclic Variations. SAE Technical Paper 2005-01-0992. 2005.
- [25] Aghdam EA, Burluka AA, Hattrell T, Liu K, Sheppard GW, Neumeister J, et al. Study of Cyclic Variation in an SI Engine Using Quasi-Dimensional Combustion Model. SAE Technical Paper 2007-01-0939. 2007.
- [26] T.K.Chandrashekar, kumar RH, A.J.Antony. Investigation of the Influence of Compression Ratio, Intake Air Temperature and Swirl in Intake passage on Random Cyclic Pressure Variations in Spark-Ignition Engines SAE Technical Paper 2007-01-1831. 2007.
- [27] Huang Y, Su Q, Huang Z, Zhou J, Yang M. Simulating Analysis of Methanol Combustion Process and Variations of Cycle to Cycle in Diesel Engine. SAE Technical Paper 2001-01-1985. 2001.
- [28] Cea E, Larrodé E, Gallego J. Emissions and Consumption Reductions in Heavy-Duty Vehicles by Means Optimized Engines and Fuel Systems. SAE Technical Paper 2008-01-0882. 2008.
- [29] Rakopoulos DC, Rakopoulos CD, Giakoumis EG, Papagiannakis RG, Kyritsis DC. Experimental-Stochastic Investigation of the Combustion Cyclic Variability in HSDI Diesel Engine Using Ethanol-Diesel Fuel Blends. *Fuel*. 2008;87:1478.

- [30] Özkan M. Comparative Study of the Effect of Biodiesel and Diesel Fuel on a Compression Ignition Engine's Performance, Emissions, and Its Cycle by Cycle Variations. *Energy & Fuels*. 2007;21:3627-36.
- [31] R. Longwic AKS, K. Górski, W. Lotko, G. Litak*. Cycle-to-Cycle Variation of the Combustion Process in a Diesel Engine Powered by Different Fuels. *Journal of Vibroengineering*. 2011;13:8.
- [32] Rakopoulos CD, Rakopoulos DC, Giakoumis EG, Kyritsis DC. The combustion of n-butanol/diesel fuel blends and its cyclic variability in a direct injection diesel engine. *Proceedings of the Institution of Mechanical Engineers, Part A: Journal of Power and Energy*. 2011;225:289-308.
- [33] Heywood JB. *Internal combustion engine fundamentals*: McGraw-Hill; 1988.
- [34] Pulkrabek WW. *Engineering fundamentals of the internal combustion engine*: Pearson Prentice Hall; 2004.
- [35] Heywood JB. *Internal Combustion Engine*. New York: McGraw Hill; 1988.
- [36] Beshai S, Deniz O, Chomiak J, Gupta AK. An Experimental Study of the Variations in Cyclic Energy Release Rate in Spark Ignition Engine. *American Institute of Aeronautics and Astronautics*. 1989;AIAA-89-2890.
- [37] Sen AK, Longwic R, Litak G, Górski K. Analysis of Cycle-to-Cycle Pressure Oscillations in a Diesel Engine. *Mechanical Systems and Signal Processing*. 2008;22:362.
- [38] Koizumi I, Gyakushi N, Takamoto Y. Study on the Cycle-by-Cycle Variation in Diesel Engines. *The Japan Society of Mechanical Engineers*, . 1977;Vol. 20:869-76.
- [39] Kalam M, Husnawan, M. A., Masjuki, H. H.,. Exhaust emission and combustion evaluation of coconut oil-powered indirect injection diesel engine. *Renewable Energy* 2003;28:2405-15.
- [40] Magin Lapuerta OA, Jose' Rodriguez-Fernandez. Effect of biodiesel fuels on diesel engine emissions. *Progress in Energy and Combustion Science* 2007;34:198–223.
- [41] Avinash Kumar A. Biofuels (alcohols and biodiesel) applications as fuels for internal combustion engines. *Progress in Energy and Combustion Science*. 2007;33:233-71.
- [42] Groeneveld RA, Meeden G. Measuring skewness and kurtosis. *The Statistician*. 1984:391-9.
- [43] Doan MP. *The roles of systematic skewness and systematic kurtosis in asset pricing*: RMIT University; 2011.