

Experimental Investigation on Active Sway Control of a Gantry Crane System using PID Controller

M.Z. Mohd Tumari, L. Shabudin, M. R. Daud and M.A. Zawawi
Robotics and Unmanned System (RUS) Group
Faculty of Electrical and Electronics Engineering
Universiti Malaysia Pahang
Pekan, 26600, Pahang, Malaysia
Email:zaidimt@ump.edu.my

Abstract— This project presents an experimental investigations into the development proportional integral derivative (PID) control schemes for active sway control of a gantry crane system. The main objective of controlling a gantry crane is to transport the load as fast as possible without causing any unnecessary swing at the final position. The proposed controller is used as a feedback control which is for controlling the crane position and therefore controlling the sway angle of the pendulum. Ziegler-Nichols method is used for tuning the PID in order to get the best performance of the system. The experiment was implemented on the lab-scale gantry crane pendulum system via CEM-Tools software. The PID control schemes guarantee a fast input tracking capability, precise payload positioning and very minimal sway motion. The performances of control schemes are examined in terms of sway angle reduction and time response specification.

Keywords— Proportional Integral Derivative (PID), Ziegler-Nichols, Gantry Crane

I. INTRODUCTION

This The main purpose of controlling a gantry crane is transporting the load as fast as possible without causing any excessive swing at the final position. However, most of the common gantry crane results in a swing motion when payload is suddenly stopped after a fast motion [1]. The swing motion can be reduced but will be time consuming. Moreover, the gantry crane need a skilful operator to control manually based on his or her experiences to stop the swing immediately at the right position. The failure of controlling crane also might cause an accident and may harm people and the surroundings.

There has recently been significant research addressing the problem of modeling and controlling gantry cranes. A dynamic mathematical model for an overhead gantry crane has been developed [2], but they assume that the cable sway angle is very small in order to linearize the nonlinear system. A controller was then designed for this linear system. Unfortunately, when the acceleration of the load is not small with respect to gravitational acceleration, the assumptions made will not be justified. A model for complex loads that do not approximate simple pendulum motion has been developed in [3]. However, the control algorithm is input shaping, where a feed-forward system is used that is susceptible to output disturbances such as wind forces on the container.

Open loop time optimal strategies also were applied to the crane by many researchers such as discussed in [4,5]. They came out with poor results because open loop strategy is sensitive to the system parameters (e.g. rope length) and could not compensate for wind disturbances. Another open loop strategy is the input shaping introduced by [6,7,8,11]. However the input shaping method is still an open-loop approach.

Feedback control which is well known to be less sensitive to disturbances and parameter variations is also adopted for controlling the gantry crane system. PD (proportional + derivative) controllers was proposed in [1] for both position and anti-swing controls. However, the performance of the controller is not very effective in eliminating the steady state error. Furthermore, a fuzzy-based intelligent gantry crane system has been proposed [9]. Nevertheless, the fuzzy logic controller design is sophisticated in finding the membership function, satisfactory rules, fuzzification and defuzzification parameter heuristically.

A neural network two degree of freedom PID controller has been proposed in [10] to control the swing motion and trolley position. As the gantry crane has lots of dynamic characteristics, PID parameters must be changed in varying conditions automatically. At these points, it is important to tune the parameters of the PID control adaptively using a neural network self-tuner.

In this study, the PID controller with Ziegler-Nichols tuning method has been proposed to reduce the sway angle of the pendulum and precise positioning of the crane. PID provides a constant system output at a specified set point. The desired closed loop dynamics is obtained by adjusting the three parameters such as Proportional gain (KP), Integral time (Ti) and Derivative time (Td), often iteratively by tuning and without specific knowledge of a plant model.

The rest of this report is organized in the following manner. The next section provides the modeling of the gantry crane system. In section three, provides the design of PID control schemes. Section four discuss on the experimental setup. Sections five discuss the implementation results. Finally, concluding remarks are offered in the last section.

II. MODELING OF GANTRY CRANE SYSTEM

The two-dimensional gantry crane system with payload is considered in this work. Fig. 1 shows the gantry crane model, where x is the horizontal position of the cart, L is the length of the rope, θ is the sway angle of the rope, M and m is the mass of the cart and payload respectively. The cart and the payload can be considered as point masses and are assumed to move in two-dimensional, x-y plane. The tension force that may cause the hoisting rope is also ignored. In this study the length of the cart, $L = 0.5$ m, $M = 2.49$ kg, $m = 0.5$ kg and $g = 9.81$ m/s² is considered.

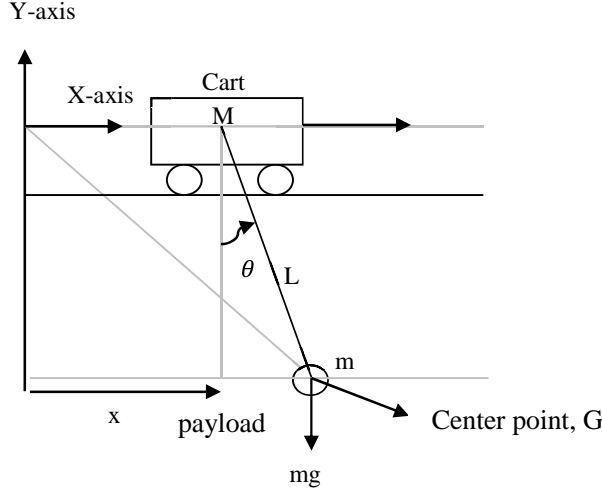

Fig. 1. Gantry Crane Model

The state space of gantry crane is represents in equation (1-3).

$$\dot{x} = Ax + Bu \quad (1)$$

$$y = Cx + Dx \quad (2)$$

$\begin{matrix} \text{cart position} \\ \text{cart velocity} \\ \text{bar's angle} \\ \text{bar's angle rate} \end{matrix}$

$$\dot{x} = \begin{bmatrix} 0 & 0 & 1 & 0 \\ 0 & 0 & 0 & 1 \\ 0 & \frac{m \cdot g}{M} & 0 & 0 \\ 0 & -\frac{((M+m) \cdot g)}{M \cdot L} & 0 & 0 \end{bmatrix} \begin{bmatrix} \dot{x}_1 \\ \dot{x}_2 \\ \dot{\theta} \\ \ddot{\theta} \end{bmatrix} + \begin{bmatrix} 0 \\ 0 \\ \frac{1}{M} \\ -\frac{1}{M \cdot L} \end{bmatrix}$$

$$C = [1 \quad 0 \quad 0 \quad 0]$$

$$D = [0] \quad (3)$$

III. PID CONTROL SCHEMES

Proportional Integrated Derivative (PID) control is the most popular feedback controller used within the process industries involved in controlling the crane position. Stability

can often be ensured using only the proportional term. The integral term permits the rejection of a step disturbance. The derivative term is used to provide damping or shaping of the response. The PID control scheme is named after its three correcting terms, whose sum constitutes the manipulated variable.

i. In Time Domain

$$MV(t) = K_p \left(e(t) + \frac{1}{T_i} \int_0^t e(t) dt + T_d \frac{de(t)}{dt} + I \right)$$

ii. In Frequency Domain

$$MV(s) = K_p \left(1 + \frac{1}{T_i s} + T_d s \right) E(s)$$

where,

MV : Manipulated Variable
 K_p : Proportional gain
 T_i : Integral time
 T_d : Derivative time
 $e(t)$: error signal

The PID controller calculate the control signal $u(t)$ as mathematically processing the error signal as shown in equation (4)

$$u(t) = K_p e(t) + K_i \int e(t) dt + K_d \frac{de(t)}{dt} \quad (4)$$

The improvement of the PID controller performance depends on the method that gains are defined. When (4) is converted into Laplace transform, the result in shown in the equation (5)

$$\frac{U(s)}{E(s)} = \frac{K_p s^2 + K_i s + K_d}{s} \quad (5)$$

The PID control scheme is named after its three correcting terms, whose sum constitutes the manipulated variable (MV) as shown in Fig. 2.

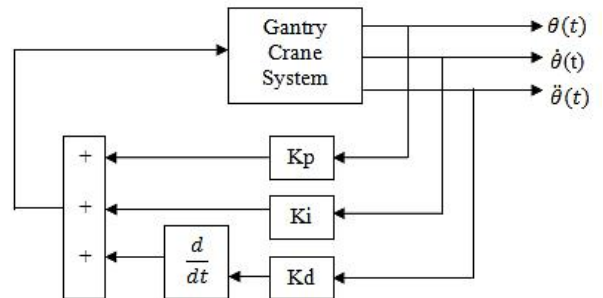

Fig. 2. The PID controller structure

PID controller is tuned by using Ziegler-Nichols Frequency Response Method. Firstly, the critical gain, K_{cr} and the critical period, P_{cr} have to be determined by setting the $T_i = \infty$ and $T_d = 0$. Then, the value of K_p was increased from 0 to a critical value. Then, gain is adjusted to make the

oscillations continue with constant amplitude as shown in Fig. 3, the value of K_{cr} is at which the output first exhibits sustained oscillation. Table 1 shows the formula of PID controller tuning parameters for the second method of Ziegler-Nichols.

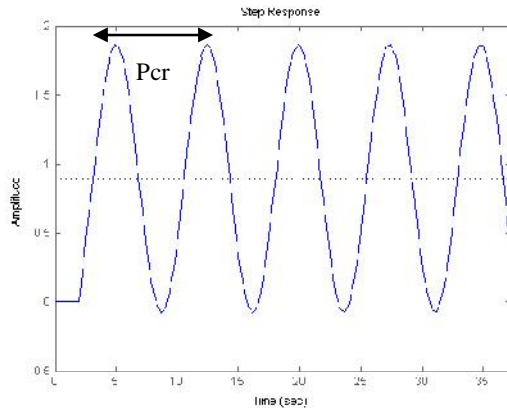

Fig. 3. Step Response for Critical Period

Table 1. Formula of PID controller tuning parameters for the second method of Ziegler-Nichols

PID TYPE	K_p	K_i	K_d
P	$0.5 K_{cr}$	∞	0
PI	$0.45 K_{cr}$	$\frac{P_{cr}}{1.2}$	0
PID	$0.6 K_{cr}$	$1/\left(\frac{P_{cr}}{2}\right)$	$\frac{P_{cr}}{8}$

Block diagram of gantry crane system with PID control schemes is shown in Figure 3.

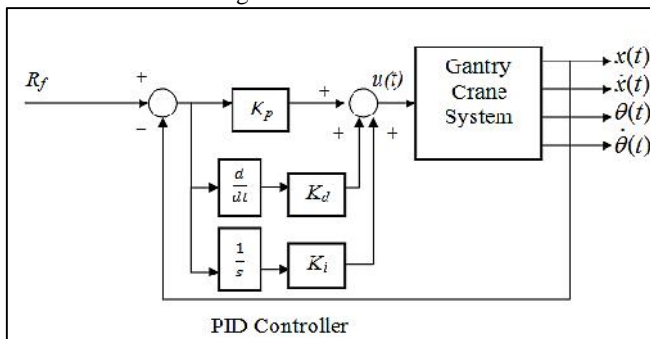

Fig. 3. Block diagram of gantry crane system with PID control schemes

IV. EXPERIMENTAL SETUP

The lab-scale gantry crane system that been used to run the experiment is shown in Figure 4. The details specification is shown in Table 2.



Fig. 4. Lab-scale gantry crane system

Table 2. Lab-scale gantry crane specifications

Item		Specification
Mechanical	W x L x H (mm)	1330 x 200 x 250
	Length of pendulum (L)	0.5 m
	Weight of pendulum (M)	0.5 Kg
	Weight of the cart (m)	2.49 Kg
	Displacement movement	900 mm
	Ball screw pitch	12.7 mm
Electrical	Motor output	24 V, 60 W
	Maximum rotation of motor	3800 rpm
	Encoder Pulse	4000 pulse
	Motor input voltage	0 – 5 V

The pendulum system used in this study transmits the rotational power of the motor that is generated as the motor rotates through the ball screw and the rotation is changed into the straight line motion. The straight line motion of the ball screw moves the cart that is connected to it and the pendulum angle that is connected to the cart is controlled. The gantry crane system requires two sensors and the pendulum angle is recognized by the encoder that is connected to the pendulum. The location of the cart is recognized by the encoder that is connected to the motor.

The hardware was interfaced with software by using industrial personal computer (Pentium IV, CPU 2.4GHz). The encoder sensor's signals from the angle and cart motion are connected to the analogue I/O Port of RG-DSPIO01 with a voltage range of -10 V to +10 V. The output of the controller is also sent to the analogue I/O Port of RGDSPIO01 using 25P connector. The PID control techniques algorithm is implemented in CEM-Tool software with the sampling period selected at 1 ms.

Fig. 5 and 6 shows the complete block diagram of SIM-Tools model design with and without controller based on PID control schemes. The input for the system is bang-bang input

to the cart. Then, the data for angle of the sway and position of the cart are collected.

The results of the experiment are compared between with and without a controller. The time response specifications of rise time, settling time, overshoot and attenuation sway angle of the pendulum were recorded. Finally, a comparative assessment of the control techniques is presented and discussed.

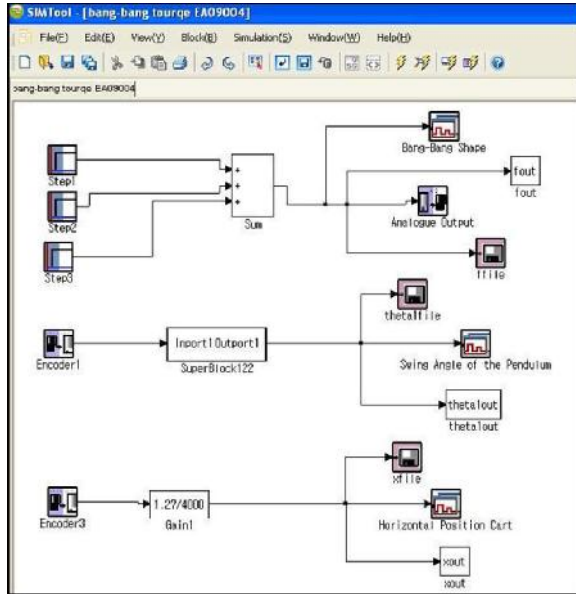

Fig. 5. The SIM-Tools model design without PID

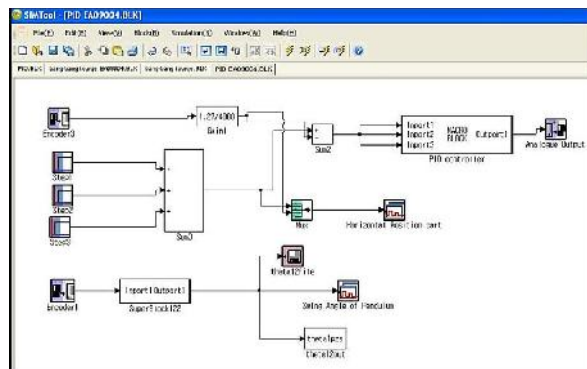

Fig. 6. The SIM-Tools model design with PID

V. RESULTS AND DISCUSSION

In this investigation, the PID control schemes are implemented on gantry crane system and the corresponding results are presented. Fig. 7 shows the horizontal position of cart and sway angle of the pendulum of gantry crane without using PID controller. The maximum amplitude of sway angle of the pendulum is ± 13.34 rad. For horizontal position of the cart, the cart was moved about 43.24 cm for 3 seconds. Then, the cart come back to the starting position and stops after about 11 seconds. This unwanted movement was caused by

the uncontrolled behavior of the system. It is noted that a sway occurred during the movement of the pendulum.

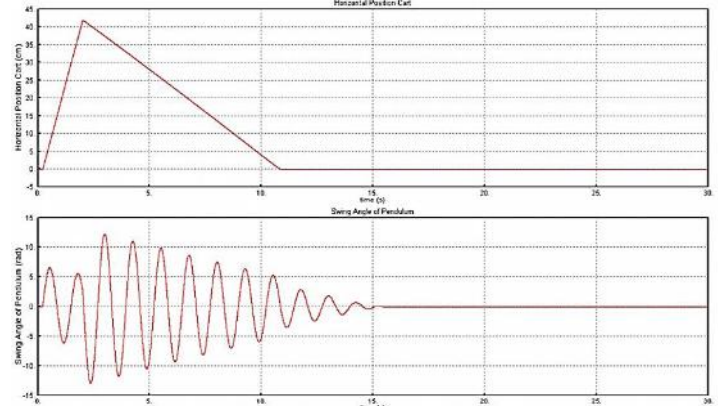

Fig. 7. The horizontal position of the cart and sway angle of the pendulum without PID

Fig. 8 shows the horizontal position of cart of and sway angle of the pendulum of gantry crane after PID control schemes being applied to the system. The level sway reduction of the pendulum in Figure 8 shows a reduction in amplitude of sway angle of the pendulum is equal to ± 5 rad compared to without the PID since the energy is transferred through the pendulum and also considering the gravitational effect. It is noted that the value of Proportional ($P=350$), Integral ($I=385$) and Derivative ($D=90$) may produce a good result in term of sway reduction.

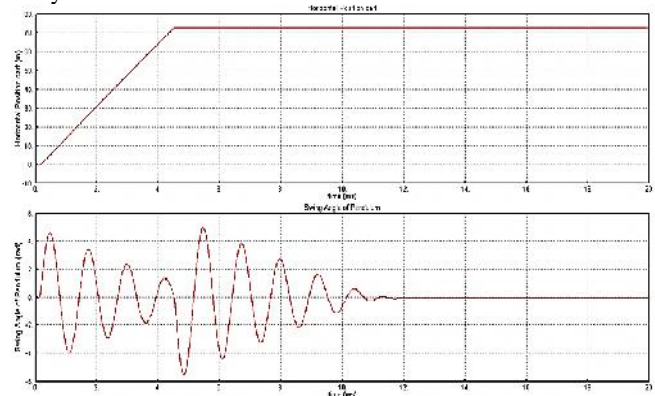

Fig. 8. The horizontal position of the cart and sway angle of the pendulum with PID

Table 3 summarizes the levels of sway reduction of the system responses with and without controller at the first mode. By comparing the result, it is noted the highest performance in the reduction of sway is achieved using PID control scheme.

Table 3. Level of sway reduction responses with and without controller

Types Of Controller	Value PID mode	Amplitude of sway angle of the pendulum (rad)
Uncontrolled		± 13.34
PID	P=350, I=385, D=90	± 5

In terms of time response specification, the system with PID controller provides a good performance with no overshoot, fast rise time and settling time compare to uncontrolled system. The results are depicted in Table 4.

Table 4. Time response specification of horizontal position of cart response

Types Of Controller	Rise Time, Tr (s)	Settling Time, Ts (s)	Overshoot (%)
Uncontrolled	9	11	43
PID	3	4.2	0

VI. CONCLUSION

At the end of this project, active sway control of gantry crane by using PID control schemes has been presented. The main objective in this project which is to reduce the sway of the gantry crane system had been implemented. In overall, the feedback controller based on PID control schemes provides better performance in sway reduction and time response specifications as compared to the uncontrolled techniques.

ACKNOWLEDGMENT

This work was supported by Faculty of Electrical & Electronics Engineering, Universiti Malaysia Pahang, especially Robotics and Unmanned System (RUS) Group under UMP short term Research Grant Scheme RDU100112 and RDU110374.

REFERENCES

- [1] Omar, H.M, Control of gantry and tower cranes. Ph.D. Thesis, M.S. Virginia Tech, 2003.
- [2] Butler, H., Honderd, G., Van Amerongen, J., "Model reference adaptive control of a gantry crane scale model", Control Systems Magazine, IEEE Volume: 11 Issue: 1, Jan, 1991 Page(s): 57 -62.
- [3] Kenison, M., Singhose, W., "Input Shaper Design for Double- Pendulum Planar Gantry Cranes", Proceedings of the IEEE International Conference on Control Applications, 22-27 Aug. 1999 vol. 1, pp. 539 -544.
- [4] G.A. Manson, "Time-Optimal Control of and Overhead Crane Model," Optimal Control Applications & Methods, 3(2), 1992, pp. 115-120.
- [5] J. Auernig and H. Troger, "Time Optimal Control of Overhead Cranes with Hoisting of the Load," Automatica, 23(4), 1987, pp. 437-447.
- [6] Karnopp, B H., Fisher, F.E., and Yoon, B.O., "A strategy for moving mass from one point to another", Journal of the Franklin Institute, Vol. 329, 1992, pp. 881-892.
- [7] Teo, C.L., Ong, C. J. and Xu, M. Pulse input sequences for residual vibration reduction. Journal of Sound and Vibration, Vol. 211, No. 2, 1998, pp. 157-177.
- [8] Singhose, W.E., Porter L.J. and Seering, W., "Input shaped of a planar gantry crane with hoisting", Proc. of the American Control Conference, 1997, pp. 97-100.
- [9] Wahyudi and Jalani, J. Design and implementation of fuzzy logic controller for an intelligent gantry crane system, Proceedings of the 2nd International Conference on Mechatronics, 2005, pp. 345- 351.
- [10] Choi, S.U., Kim, J.H., Lee, J.W., Lee, Y.J., Lee, K.S., "A study on gantry crane control using neural network two degree of PID controller", Proceedings of the International Symposium on. Industrial Electronics, Pusan, Korea, pp. 1896-1900, 2001.
- [11] M.A. Ahmad, Z. Zulkifely, M.A. Zawawi. Experimental Investigations of Input Shaping Schemes for Sway Control of a Gantry Crane System, Second International Conference on Computer and Network Technology, 2010, pp.483-386.