

**ADSORPTION SEPARATION OF HEAVY METALS FROM SIMULATED  
WASTE WATER USING ORANGE WASTE**

**MOHD AZRUL HISYAM BIN MOHD NORAWI**

**UNIVERSITY COLLEGE OF ENGINEERING & TECHNOLOGY  
MALAYSIA**

**KOLEJ UNIVERSITI KEJURUTERAAN DAN  
TEKNOLOGI MALAYSIA**

**BORANG PENGESAHAN STATUS TESIS**

JUDUL                    **ADSORPTION SEPARATION OF HEAVY METALS FROM  
SIMULATED WASTE WATER USING ORANGE WASTE**

SESI PENGAJIAN: **2005/2006**

Saya                    **MOHD AZRUL HISYAM BIN MOHD NORAWI**  
(HURUF BESAR)

mengaku membenarkan tesis (PSM/Sarjana/Doktor Falsafah)\* ini disimpan di Perpustakaan Kolej Universiti Kejuruteraan dan Teknologi Malaysia dengan syarat-syarat kegunaan seperti berikut:

1. Tesis adalah hakmilik Kolej Universiti Kejuruteraan dan Teknologi Malaysia.
2. Perpustakaan Kolej Universiti Kejuruteraan dan Teknologi Malaysia dibenarkan membuat salinan untuk tujuan pengajian sahaja.
3. Perpustakaan dibenarkan membuat salinan tesis ini sebagai bahan pertukaran antara institusi pengajian tinggi.
4. \*\*Sila tandakan (✓)

SULIT

(Mengandungi maklumat yang berdarjah keselamatan atau kepentingan Malaysia seperti yang termaktub di dalam AKTA RAHSIA RASMI 1972)

TERHAD

(Mengandungi maklumat TERHAD yang telah ditentukan oleh organisasi/badan di mana penyelidikan dijalankan)

TIDAK TERHAD

Disahkan oleh

\_\_\_\_\_  
(TANDATANGAN PENULIS)

Alamat Tetap: **188 LORONG INTAN 1/6,  
PERAMU JAYA 03,  
26600 PEKAN, PAHANG**

Tarikh: 20<sup>th</sup> November 2006

\_\_\_\_\_  
(TANDATANGAN PENYELIA)

**SUPERVISOR**

Mior Ahmad Khushairi bin Mohd  
Zahari

Tarikh: 20<sup>th</sup> November 2006

CATATAN:

\* Potong yang tidak berkenaan.

\*\* Jika tesis ini SULIT atau TERHAD, sila lampirkan surat daripada pihak berkuasa/organisasi berkenaan dengan menyatakan sekali sebab dan tempoh tesis ini perlu dikelaskan sebagai SULIT atau TERHAD.

◆ Tesis dimaksudkan sebagai tesis bagi Ijazah Doktor Falsafah dan Sarjana secara penyelidikan, atau disertai bagi pengajian secara kerja kursus dan penyelidikan, atau Laporan Projek Sarjans Muda (PSM).

“I hereby acknowledge that I had read this technical writing and in my opinion this technical writing is sufficient in terms of scope and quality for the purpose of the granting of Bachelor of Chemical Engineering.”

Signature : .....

Name of Supervisor : Mior Ahmad Khushairi bin Mohd Zahari

Date : 20<sup>th</sup> November 2006

ADSORPTION SEPARATION OF HEAVY METALS FROM SIMULATED  
WASTE WATER USING ORANGE WASTE

MOHD AZRUL HISYAM BIN MOHD NORAWI

A thesis submitted in fulfillment  
of the requirements for the award of the degree of  
Bachelor of Chemical Engineering

Faculty of Chemical & Natural Resources Engineering  
University College of Engineering & Technology Malaysia

November, 2006

## DECLARATION

I declare that this thesis entitled “Adsorption separation of heavy metals from simulated waste water using orange waste” is the result of my own research except as cited in references. The thesis has not been accepted for any degree and is not concurrently submitted in candidature of any other degree.”

Signature : .....

Name of Candidate : Mohd Azrul Hisyam bin Mohd Norawi

Date : November 20<sup>th</sup> , 2006

**DEDICATION**

*Special Dedication to my family members that always love me,  
My friends, my fellow colleague  
and all faculty members*

*For all your Care, Support and Believe in me.*

*Sincerely  
Mohd Azrul Hisyam*

## ACKNOWLEDGEMENTS

It is important to pay tribute when it is due and I personally would like to acknowledge the many wonderful people that have guided me and support me in completing this thesis.

In preparing this thesis, I was in contact with many people, academicians and practitioners. They have contributed toward my understanding and thoughts during this project development. In particular, I wish to express my sincere appreciation to my thesis supervisor, En Mior Ahmad Khushairi bin Mohd Zahari for his encouragement, guidance, critics and advise. Without his continued support and interest, this thesis would not be a success.

I am also indeed gratitude to the entire lecture in the Faculty of Chemical Engineering & Natural Resources (FKKSA) for their support and motivation in completing my undergraduate project. Also thankfulness to my beloved person in my life it is my parent and my entire family member for their support throughout my study.

My fellow friends should also be recognized for their support especially Shahrizal Ramli(roommate), Ahmad Fadzli Zakaria, Norhamly Mohd Nor and Mohd Hafiz Mohd Saad . Their view and tips are indeed useful. Unfortunately, it is not possible to list all of them in this limited space.

## ABSTRACT

Orange waste is one of the resources to provide an adsorption gel for metal ion by simple chemical modification. Two types of adsorption gels,  $\text{Ca}^{2+}$ -form and  $\text{H}^+$ -form gels, were prepared by saponifying orange juice residues with calcium hydroxide and its subsequent acid treatment, respectively. The  $\text{Ca}^{2+}$ -form gel was effective for the complete and selective removal of  $\text{Pb(II)}$ ,  $\text{Cd(II)}$ ,  $\text{Zn(II)}$ ,  $\text{Mn(II)}$  compared with other divalent metal ions. The selectivity order for metal ion uptake by the gel is  $\text{Pb(II)} > \text{Cd(II)} > \text{Zn(II)} > \text{Mn(II)}$ . The experimental results clearly suggest that both gels are quite effective for removing heavy metal ions in acidic pH ranges.



## ABSTRAK

Bahan buangan seperti kulit oren adalah salah satu sumber bagi penghasilan gel penjerapan bagi ion logam dengan menggunakan kaedah pengubahsuaian kimia. Dua jenis gel penyerap, dalam bentuk  $\text{Ca}^{2+}$  and  $\text{H}^+$  gel, boleh disediakan melalui proses saponifikasi kulit buah oren bersama kalsium hidroksida dan berikutnya menggunakan rawatan asid. Gel dalam bentuk  $\text{Ca}^{2+}$  adalah lebih efektif dan kememilihan penyikiran bagi  $\text{Pb(II)}$ ,  $\text{Cd(II)}$ ,  $\text{Zn(II)}$ ,  $\text{Mn(II)}$ . Urutan pemilihan bagi gel ini ialah  $\text{Pb(II)} > \text{Cd(II)} > \text{Zn(II)} > \text{Mn(II)}$ . Keputusan eksperimen jelas sekali menunjukkan bahan gel yang dihasilkan agak efektif untuk digunakan dalam penyikiran ion logam dalam lingkungan pH yang ditetapkan.

## TABLE OF CONTENTS

CHAPTER	TITLE	PAGE
	<b>TITLE PAGE</b>	<b>i</b>
	<b>DECLARATION OF ORIGANALITY &amp; EXCLUSIVENESS</b>	<b>ii</b>
	<b>DEDICATION</b>	<b>iii</b>
	<b>ACKNOWLEDGEMENT</b>	<b>iv</b>
	<b>ABSTRACT</b>	<b>v</b>
	<b>ABSTRAK</b>	<b>vi</b>
	<b>TABLE OF CONTENT</b>	<b>vii</b>
	<b>LIST OF TABLE</b>	<b>x</b>
	<b>LIST OF FIGURE</b>	<b>xi</b>
	<b>LIST OF ABBREVIATIONS</b>	<b>xii</b>
<b>1.0</b>	<b>INTRODUCTION</b>	<b>1</b>
	1.1 Introduction	<b>1</b>
	1.2 Objectives of research	<b>3</b>
	1.3 Scopes of study	<b>3</b>
	1.4 Problem statement	<b>3</b>
<b>2.0</b>	<b>LITETATURE REVIEW</b>	<b>5</b>
	2.1 Atomic absorption spectrophotometer	<b>5</b>
	2.1.1 Introduction	<b>5</b>
	2.1.2 How AAS Functioning	<b>6</b>
	2.1.3 The Light Source	<b>7</b>
	2.1.4 The Optical System and Detector	<b>8</b>
	2.1.5 Double Beam Spectrometers	<b>8</b>
	2.1.6 Atomization of the Sample	<b>9</b>
	2.1.7 Flame Aspiration	<b>9</b>
	2.1.8 Electro Thermal Atomization	<b>10</b>

	2.1.9	Sample Preparation	11
2.2		Absorption	11
	2.2.1	Background Absorption	11
	2.2.2	Calibration	12
	2.2.3	Interferences and Matrix Modification	13
	2.2.4	A Bad Paint Job	14
2.3		Adsorption Process	14
2.4		Physical Properties of Adsorbents	15
2.5		Heavy Metal	16
	2.5.1	Definition of Heavy Metal	17
	2.5.2	Toxic Heavy Metal	17
<b>3.0</b>		<b>MATERIAL &amp; METHODS</b>	<b>19</b>
	3.1	Introduction	19
	3.2	Stage of Experiment	19
	3.3	Preparation of the Adsorption Gel	21
	3.4	Preparation of H <sup>+</sup> -form SOW Gel	22
	3.5	Incubation Process	22
	3.6	Adsorption Analysis	23
<b>4.0</b>		<b>RESULT &amp; DISCUSSION</b>	<b>25</b>
	4.1	Adsorptive Removal of Metal Ions	25
	4.2	Adsorption Mechanism	29
<b>5.0</b>		<b>CONCLUSION &amp; RECOMMANDATION</b>	<b>30</b>
	5.1	Conclusion	30
	5.2	Recommandation	31
	5.2.1	Proposal for the post-treatment of the metal-loaded gel	31

<b>6.0</b>	<b>REFERENCE</b>	<b>33</b>
<b>7.0</b>	<b>APPENDIX</b>	<b>35</b>

**LIST OF TABLES**

<b>Table</b>	<b>Title</b>	<b>Page</b>
2.1	Parameter Limit for Standard A and Standard B	<b>17</b>
4.1	Result of Analysis from AAS for Ca <sup>2+</sup> -Form SOW Cake	<b>26</b>
4.2	Result of Analysis from AAS for H <sup>+</sup> -Form SOW Cake	<b>28</b>

## LIST OF FIGURES

<b>Figure</b>	<b>Title</b>	<b>Page</b>
2.1	Hollow Cathode Lamp	7
2.2	Example of Excited States and Emit Radiation	7
2.3	Produces an Electrical Signal Proportional to the Light Intensity	8
2.4	Modern Spectrometers	9
2.5	Typical Burner and Spray Chamber	10
2.6	Graphite Tube with a Platform	11
2.7	Concentration against the Amount of Radiation Absorbed	13
2.8	The Calibration Curve	13
3.1	Stage of Experimental	20
3.2	Drying Process in convection oven	21
3.3	Methyl ester groups were saponified with saturated calcium hydroxide solution to convert them into carboxyl groups	22
3.4	Incubation Process	23
3.5	Absorption Test	24
4.1	SOW Cake	25
4.2	Removal of Some Metal Ion on the Ca <sup>2+</sup> -form SOW as a Function of Equilibrium pH. Weight of the Gel = 0.1 g. Volume of the Simulated Waste Water = 60 ml. Initial Metal Concentration = 5 ppm	26
4.3	Removals of Some Metal Ion on the H <sup>+</sup> -form SOW as a Function of Equilibrium pH. Weight of the Gel = 0.1 g. Volume of the Simulated Waste Water = 60 ml. Initial Metal Concentration = 5 ppm	28

**LIST OF ABBREVIATIONS**

Symbols	Title
SOW	Saponification Orange Waste
°C	Degree Celsius
°F	Degree Fahrenheit
mg	Milligram
h	Hour
mM	Millimol
AAS	Atomic Adsorption Spectrophotometer
$\mu\text{g dm}^{-3}$	parts per billion of a gram
Hz	hertz
V	Volt
ATSDR	The Agency for Toxic Substances and Disease Registry
$\text{cm}^3$	Centimeter cubic
pH	potential hydrogen
Co	Initial concentration
Cc	After adsorption concentration
R	The percentage of adsorption
rpm	radius per minutes

## CHAPTER 1

### INTRODUCTION

#### 1.1 Introduction

Many industrial waste water effluents, particularly from mineral processing, metal plating; electric, electronic and chemical industries are environmentally unacceptably contaminated with heavy metals. Currently practiced treatment methods for these effluents include flotation, coagulation/precipitation, membrane processes, electrochemical techniques, and ion exchange.

Almost all of them have some drawbacks including high operating cost. Precipitation followed by coagulation has been extensively employed because of its easy operation and low cost. The representative precipitation method is based usually on forming a metal hydroxide precipitate by adding some cheap alkaline materials like lime for removal of cationic heavy metals like Pb(II), Cd(II), Cu(II) and Ni(II). However, this process usually produces large volumes of sludge consisting of small amounts of heavy metals in excess gypsum the recycling and reuse of which is very difficult.

Although adsorptive separation methods using synthetic chelating resins with high selectivity would be another approach, they also suffer from considerable shortcomings such as high cost, post-treatment problems and their refractory nature after use.



In the past few years, biosorption, bioprecipitation, and uptake by biopolymers derived from agricultural wastes or microbes have appeared as emerging techniques that could provide alternative and/or additive processes for conventional physical and chemical methods for removing toxic ions from wastewater [2] and [3]. Hence, a lot of effort has been made on screening of efficient biomass types, their preparation and biosorption mechanism. The uptake of heavy metals by biomass can in some cases reach up to 50% of the biomass dry weight. New biosorbents can be manipulated for better efficiency and multiple re-use to increase their economic attractiveness. [4]

The adsorptive removal of heavy metals using gels of alginic acid and pectic acid which show remarkable separation features for heavy metal ions [5] and [6]. The selectivity of these gels for some specific metal ions is much superior to commercially available chelating resins and adsorption capacities are competitive. Although the physical or mechanical strength of these gels may be much weaker than the synthetic resins, they are environmental benign, biodegradable and free from post-treatment problems. Pectic acid and alginic acid gels exhibit excellent adsorption behavior for heavy metals; however, the cost of extracting these polysaccharides from their corresponding feed materials to produce the adsorption gels is high.

Large quantities of various biomass wastes are being generated in agriculture, forestry and fisheries. Some of these biomass wastes contain various natural materials with interesting functions such as pectic acid and alginic acid. If these biomass wastes exhibit the adsorption behaviors for metal ions similar to the pectic acid and alginic acid gels, it would be possible to use them successfully at very low price, as there is no need to extract the pectic acid or alginic acid [7]. We prepared an adsorption gel of orange juice residue, by cross linking with epichlorohydrine, which also exhibited excellent adsorption behavior for Pb(II) ions similar to pectic and alginic acid gels. However, cross linking with epichlorohydrine is also expensive and leaves various wastes after cross linking, which also require costly post-treatment.

In the present work, we tried to prepare another type of adsorption gel from orange juice residue, by a much cheaper and simpler method without using any organic cross linking reagents so as to avoid the problems of waste treatment after cross linking based on the presumption that the adsorption gel is not reused after adsorption, that is, from economical point of view it is used only once for adsorption.

## **1.2 Objective Of Research**

In this project, it focuses to saponify the protein from orange waste and to create an adsorbent gel that adsorbs metal from the protein saponificated

## **1.3 Scope of thesis**

The work carried out in this project will be divided into two stages. Firstly is to preparation of adsorbent gel from orange waste. In this process saponification and acidification will be conducted to prepare different pH of orange gel. After that, adsorption test will be conducted by the conventional batch method using aqueous test solutions containing single metal ions. During this process, the concentration of heavy metal before and after adsorption test will be determine using Atomic Adsorption Spectrophotometer (AAS)

## **1.4 Problem statement**

The discharge of heavy metals into aquatic ecosystems has become a matter of concern over the last few decades. These pollutants are introduced into the aquatic systems significantly as a result of various industrial operations. The pollutants of concern include lead, chromium, mercury, uranium, selenium, zinc, arsenic, cadmium, gold, silver, copper and nickel. These toxic materials may be derived from

mining operations, refining ores, sludge disposal, fly ash from incinerators, the processing of radioactive materials, metal plating, or the manufacture of electrical equipment, paints, alloys, batteries, pesticides or preservatives. Heavy metals such as zinc, lead and chromium have a number of applications in basic engineering works, paper and pulp industries, leather tanning, organ chemicals, petrochemicals fertilizers, etc. Major lead pollution is through automobiles and battery manufacturers.

## CHAPTER 2

### LITERATURE REVIEW

#### 2.1 Atomic absorption spectrophotometer

##### 2.1.1 Introduction

Atomic absorption spectrometry (AAS) is an analytical technique that measures the concentrations of elements. Atomic absorption is so sensitive that it can measure down to parts per billion of a gram ( $\mu\text{g dm}^{-3}$ ) in a sample. The technique makes use of the wavelengths of light specifically absorbed by an element. They correspond to the energies needed to promote electrons from one energy level to another, higher, energy level. Atomic absorption spectrometry has many uses in different areas of chemistry.

**Clinical analysis.** Analyzing metals in biological fluids such as blood and urine.

**Environmental analysis.** Monitoring our environment – *e.g.* finding out the levels of various elements in rivers, seawater, drinking water, air, petrol and drinks such as wine, beer and fruit drinks.

**Pharmaceuticals.** In some pharmaceutical manufacturing processes, minute quantities of a catalyst used in the process (usually a metal) are sometimes present in the final product. By using AAS the amount of catalyst present can be determined.

**Industry.** Many raw materials are examined and AAS is widely used to check that the major elements are present and that toxic impurities are lower than specified – *e.g.* in concrete, where calcium is a major constituent, the lead level should be low because it is toxic.

**Mining.** By using AAS the amount of metals such as gold in rocks can be determined to see whether it is worth mining the rocks to extract the gold.

### 2.1.2 How AAS Functioning

Atoms of different elements absorb characteristic wavelengths of light. Analyzing a sample is to see if it contains a particular element means using light from that element. For example with lead, a lamp containing lead emits light from excited lead atoms that produce the right mix of wavelengths to be absorbed by any lead atoms from the sample. In AAS, the sample is atomized – *i.e.* converted into ground state free atoms in the vapor state – and a beam of electromagnetic radiation emitted from excited lead atoms is passed through the vaporized sample. Some of the radiation is absorbed by the lead atoms in the sample.

The greater the number of atoms there is in the vapor, the more radiation is absorbed. The amount of light absorbed is proportional to the number of lead atoms. A calibration curve is constructed by running several samples of known lead concentration under the same conditions as the unknown. The amount the standard absorbs is compared with the calibration curve and this enables the calculation of the lead concentration in the unknown sample. Consequently an atomic absorption spectrometer needs the following three components: a light source; a sample cell to produce gaseous atoms; and a means of measuring the specific light absorbed.

### 2.1.3 The light source

The common source of light is a ‘hollow cathode lamp’ as show as figure 2.1. This contains a tungsten anode and a cylindrical hollow cathode made of the element to be determined. These are sealed in a glass tube filled with an inert gas – *e.g.* neon or argon – at a pressure of between  $1 \text{ Nm}^{-2}$  and  $5 \text{ Nm}^{-2}$ .

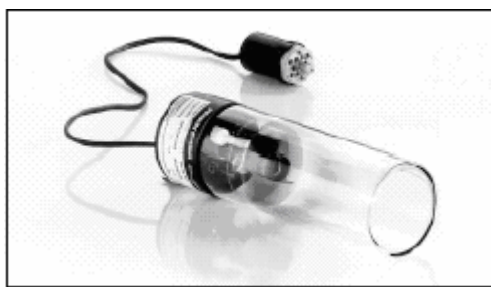

**Figure 2.1: Hollow Cathode Lamp**

The ionization of some gas atoms occurs by applying a potential difference of about 300–400 V between the anode and the cathode. These gaseous ions bombard the cathode and eject metal atoms from the cathode in a process called sputtering. Some sputtered atoms are in excited states and emit radiation characteristic of the metal as they fall back to the ground state – *e.g.*  $\text{Pb}^* \rightarrow \text{Pb} + h$  as show as figure 2.2. The shape of the cathode concentrates the radiation into a beam which passes through a quartz window, and the shape of the lamp is such that most of the sputtered atoms are red positing on the cathode.

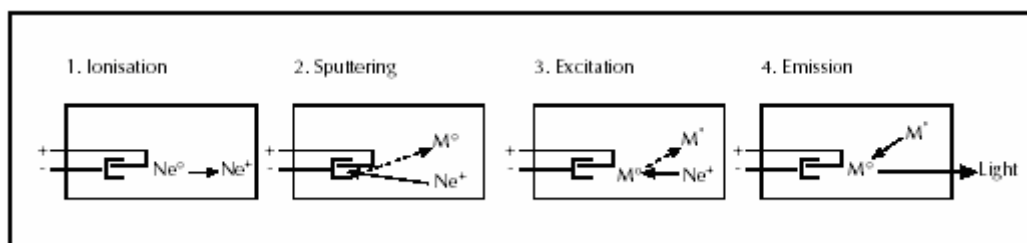
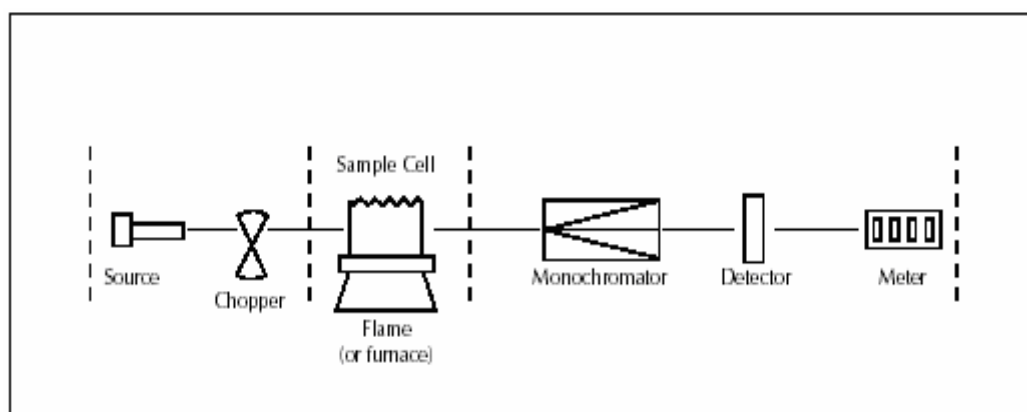

**Figure 2.2: Example of Excited States and Emit Radiation**

A typical atomic absorption instrument holds several lamps each for a different element. The lamps are housed in a rotating turret so that the correct lamp can be quickly selected.

#### 2.1.4 The optical system and detector

A monochromator is used to select the specific wavelength of light – *i.e.* spectral line which is absorbed by the sample, and to exclude other wavelengths. The selection of the specific light allows the determination of the selected element in the presence of others. The light selected by the monochromator is directed onto a detector that is typically a photomultiplier tube. This produces an electrical signal proportional to the light intensity as show in figure 2.3.

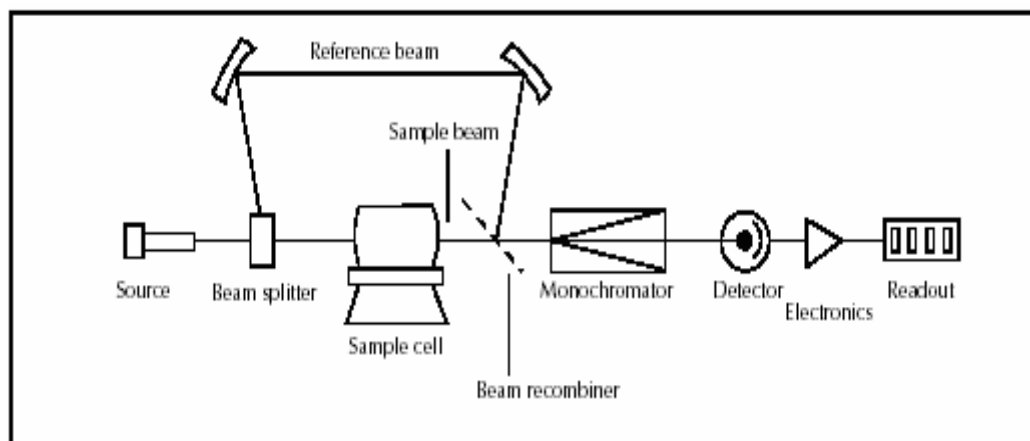

**Figure 2.3: Produces an Electrical Signal Proportional to the Light Intensity**

#### 2.1.5 Double beam spectrometers

Modern spectrometers incorporate a beam splitter so that one part of the beam passes through the sample cell and the other is the reference as show as figure 2.4. The intensity of the light source may not stay constant during an analysis. If only a single beam is used to pass through the atom cell, a blank reading containing no analyte (substance to be analyzed) would have to be taken first, setting the absorbance at zero. If the intensity of the source changes by the time the sample is put in place, the measurement will be inaccurate. In the double beam instrument

there is a constant monitoring between the reference beam and the light source. To ensure that the spectrum does not suffer from loss of sensitivity, the beam splitter is designed so that as high a proportion as possible of the energy of the lamp beam passes through the sample.



**Figure 2.4: Modern Spectrometers**

### 2.1.6 Atomization of the sample

Two systems are commonly used to produce atoms from the sample. Aspiration involves sucking a solution of the sample into a flame; and electro thermal atomization is where a drop of sample is placed into a graphite tube that is then heated electrically. Some instruments have both atomization systems but share one set of lamps. Once the appropriate lamp has been selected, it is pointed towards one or other atomization system.

### 2.1.7 Flame aspiration

Figure 2.5 shows a typical burner and spray chamber. Ethyne/air (giving a flame with a temperature of 2200–2400  $\pi$ C) or ethyne/dinitrogen oxide (2600– 2800  $\pi$ C) are often used. A flexible capillary tube connects the solution to the nebuliser. At



the tip of the capillary, the solution is ‘nebulised’ – *ie* broken into small drops. The larger drops fall out and drain off while smaller ones vaporize in the flame. Only *ca* 1% of the sample is nebulised.

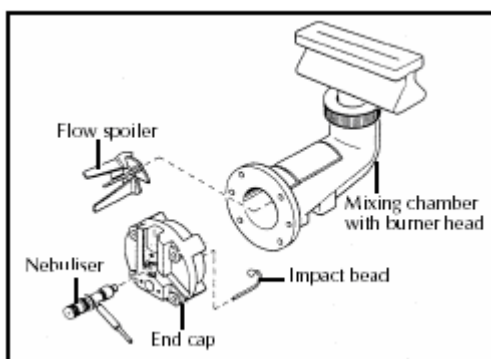

**Figure 2.5: Typical Burner and Spray Chamber**

#### 2.1.8 Electro thermal atomization

Figure 2.6 shows a hollow graphite tube with a platform. 25  $\mu$ l of sample (*ca* 1/100th of a raindrop) is placed through the sample hole and onto the platform from an automated micropipette and sample changer. The tube is heated electrically by passing a current through it in a pre-programmed series of steps. The details will vary with the sample but typically they might be 30–40 seconds at 150  $^{\circ}$ C to evaporate the solvent, 30 seconds at 600  $^{\circ}$ C to drive off any volatile organic material and char the sample to ash, and with a very fast heating rate (*ca* 1500  $^{\circ}$ C s<sup>-1</sup>) to 2000– 2500  $^{\circ}$ C for 5–10 seconds to vaporize and atomize elements (including the element being analyzed). Finally heating the tube to a still higher temperature – *ca* 2700  $^{\circ}$ C – cleans it ready for the next sample. During this heating cycle the graphite tube is flushed with argon gas to prevent the tube burning away. In electro thermal atomization almost 100% of the sample is atomized. This makes the technique much more sensitive than flame AAS.

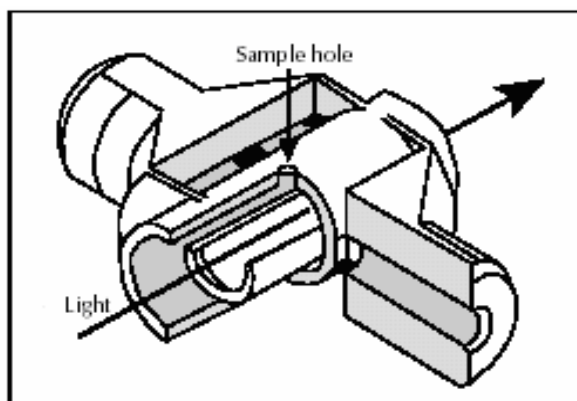

**Figure 2.6: Graphite Tube with a Platform**

### 2.1.9 Sample preparation

Sample preparation is often simple, and the chemical form of the element is usually unimportant. This is because atomization converts the sample into free atoms irrespective of its initial state. The sample is weighed and made into a solution by suitable dilution. Elements in biological fluids such as urine and blood are often measured simply after a dilution of the original sample. When making reference solutions of the element under analysis, for calibration, the chemical environment of the sample should be matched as closely as possible – *i.e.* the analyte should be in the same compound and the same solvent. Teflon containers may be used when analyzing very dilute solutions because elements such as lead are sometimes leached out of glass vessels and can affect the results. [10]

## 2.2 Absorption

### 2.2.1 Background absorption

It is possible that other atoms or molecules apart from those of the element being determined will absorb or scatter some radiation from the light source. These

species could include unvaporized solvent droplets or compounds of the matrix (chemical species, such as anions, that tend to accompany the metals being analyzed) that are not removed completely. This means that there is the background absorption as well as that of the sample.

One way of measuring and correcting this background absorption is to use two light sources, one of which is the hollow cathode lamp appropriate to the element being measured. The second light source is a deuterium lamp. The deuterium lamp produces broad band radiation, not specific spectral lines as with a hollow cathode lamp. By alternating the measurements of the two light sources – generally at 50 –100 Hz – the total absorption (absorption due to analyte atoms plus background) is measured with the specific light from the hollow cathode lamp and the background absorption is measured with the light from the deuterium lamp. Subtracting the background from the total absorption gives the absorption arising from only analyte atoms.

### 2.2.2 Calibration

A calibration curve is used to determine the unknown concentration of an element – *e.g.* lead in a solution. The instrument is calibrated using several solutions of known concentrations. A calibration curve is produced which is continually rescaled as more concentrated solutions are used the more concentrated solutions absorb more radiation up to a certain absorbance. The calibration curve shows the concentration against the amount of radiation absorbed as show as figure 2.7. The sample solution is fed into the instrument and the unknown concentration of the element. *E.g.* lead is then displayed on the calibration curve as show as figure 2.8.

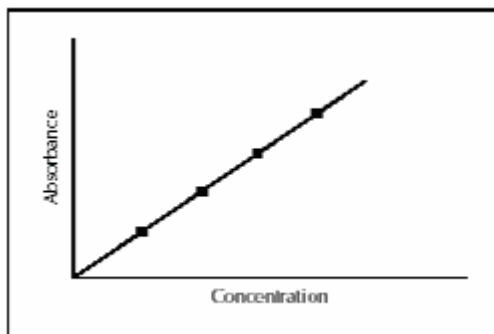

**Figure 2.7: Concentration against the Amount of Radiation Absorbed**

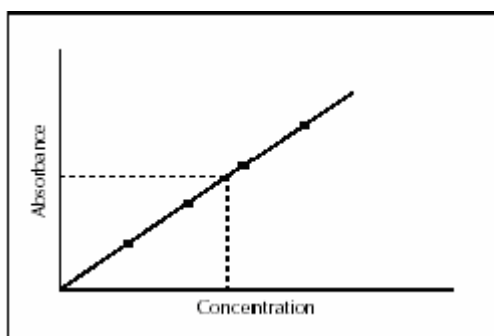

**Figure 2.8: The Calibration Curve**

### 2.2.3 Interferences and matrix modification

Other chemicals that are present in the sample may affect the atomization process. For example, in flame atomic absorption, phosphate ions may react with calcium ions to form calcium pyrophosphate. This does not dissociate in the flame and therefore results in a low reading for calcium. This problem is avoided by adding different reagents to the sample that may react with the phosphate to give a more volatile compound that is dissociated easily.

Lanthanum nitrate solution is added to samples containing calcium to tie up the phosphate and to allow the calcium to be atomized, making the calcium absorbance independent of the amount of phosphate. With electro thermal atomization, chemical modifiers can be added which react with an interfering substance in the sample to make it more volatile than the analyte compound. This

volatile component vaporizes at a relatively low temperature and is removed during the low and medium temperature stages of electro thermal atomization.

#### 2.2.4 A bad paint job

Atomic absorption spectrometry is sometimes used for investigating unusual problems. One such case was that of a seriously ill baby whose symptoms could not be explained. Lead is a toxic element that can cause poisoning in children. A baby was brought to a hospital suffering from vomiting and stomach pains, and was very drowsy. There were no obvious reasons or signs why the child should be ill. As part of the routine tests performed, the lead level in a blood sample from the child was measured using electro thermal atomization AAS.

The lead level was higher than normal and there was no known source for the lead. However, the parents explained that the child had been chewing the painted wood on its cot. The paint was also examined by dissolving it in nitric acid and then using flame AAS to find out the lead content. A very high level was found. Other paints in the baby's bedroom were found to have low lead levels. This identified the cot paint as the source of lead in the baby. The baby's cot was old and had been painted when leaded paint was very common. This type of paint is now banned from household use and by law all painted toys must be examined for lead and other toxic metals to make sure that they are safe for small children.

### 2.3 Adsorption process

In adsorption processes one or more component of a gas or liquid stream are adsorbed on the surface of a solid adsorbent and a separation is accomplished. In commercial processes, the adsorbent is usually in the form of small particles adsorb

component from fluid. When the bed is almost saturated, the flow in this bed is stopped and the bed is regenerated thermally or by other method so that desorption occurs. The adsorbed material (adsorbate) is thereby recovered and the solid adsorbent is ready for another cycle of adsorption.

Application of liquid-phase adsorption includes removal of organic compound from water or organic solution, colored impurities from organic, and various fermentation products from fermentor effluence. Separation include paraffins from aromatic and fructose from glucose using zeolites application for gas-phase adsorption include removal of water from hydrocarbon gases, sulfur compounds from natural gas, solvents from air and other gases, and odors from air

Ion exchange is a reversible chemical reaction wherein an ion (an atom or molecule that has lost or gained an electron and thus acquired an electrical charge) from solution is exchanged for a similarly charged ion attached to an immobile solid particle. These solid ion exchange particles are either naturally occurring inorganic zeolites or synthetically produced organic resins. The synthetic organic resins are the predominant type used today because their characteristics can be tailored to specific applications. An organic ion exchange resin is composed of high-molecular-weight polyelectrolytes that can exchange their mobile ions for ions of similar charge from the surrounding medium. Each resin has a distinct number of mobile ion sites that set the maximum quantity of exchanges per unit of resin. [11]

## **2.4 Physical properties of adsorbents**

Many adsorbents have been developed for a wide range of separation. Typically, the adsorbents are in the form of small pellet, beads, or granules ranging from about 0.1 mm to 12 mm in size, with the larger particles being used in packed beds. A particle of adsorbent has a very porous structure, with many fine pores and pore volume up to 50% of total particle volume. The adsorption often occurs as a monolayer of the fine pores, although several layers sometimes occur. Physical

adsorption, or van der Waals adsorption, usually occurs between the adsorption molecules and the solid internal pore surface and is readily reversible. [11]

## 2.5 Heavy metals

According to one definition, the heavy metals are a group of elements between copper and lead on the periodic table of elements having atomic weight between 63.546 and 200.59 and specific gravities greater than 4.0. Living organisms require trace amounts of some heavy metals, including cobalt, copper, molybdenum, vanadium, strontium, and zinc but excessive levels can be detrimental to the organism. Other heavy metals such as mercury, lead and cadmium have no known vital or beneficial effect on organisms, and their accumulation over time in the bodies of mammals can cause serious illness.

Heavy metals are dangerous because they tend to bioaccumulate. Bioaccumulation means an increase in the concentration of a chemical in a biological organism over time, compared to the chemical's concentration in the environment. Compound accumulation in living things any time they are taken up and stored faster than they are broken down or excreted.

Heavy metals can enter a water supply by industrial and consumer waste, or even from acidic rain breaking down soils and releasing heavy metals into streams, lakes, rivers and groundwater. [12] Table 2.1 shows the limited parameters that have been used in the Department of Environment (DOE). [13] All industries have produced heavy metals and need to follow the standard before releasing them to the river or lakes.

<b>Parameter</b>	<b>unit</b>	<b>A</b>	<b>B</b>
<b>Plumbum(II)</b>	mg/l	0.10	0.50
<b>Cadmiun(II)</b>	mg/l	0.01	0.02
<b>Mangan(II)</b>	mg/l	0.20	1.00
<b>Nikel(II)</b>	mg/l	0.20	1.00
<b>Zink(II)</b>	mg/l	2.00	2.00
<b>Ferum(II)</b>	mg/l	1.00	5.00

**Table 2.1: Parameter Limit for Standard A and Standard B**

### 2.5.1 Definition of Heavy Metal

"Heavy metals" are chemical elements with a specific gravity that is at least 5 times the specific gravity of water. The specific gravity of water is 1 at 4°C (39°F). Simply stated, specific gravity is a measure of density of a given amount of a solid substance when it is compared to an equal amount of water. Some well-known toxic metallic elements with a specific gravity that is 5 or more times that of water are arsenic, 5.7; cadmium, 8.65; iron, 7.9; lead, 11.34; and mercury, 13.546.

### 2.5.2 Toxic Heavy Metal

Heavy metals become toxic when they are not metabolized by the body and accumulate in the soft tissues. Heavy metals may enter the human body through food, water, air, or absorption through the skin when they come in contact with humans in agriculture and in manufacturing, pharmaceutical, industrial, or residential settings. Industrial exposure accounts for a common route of exposure for adults. Ingestion is the most common route of exposure in children. Children may develop toxic levels from the normal hand-to-mouth activity of small children who come in contact with



contaminated soil or by actually eating objects that are not food (dirt or paint chips). Less common routes of exposure are during a radiological procedure, from inappropriate dosing or monitoring during intravenous (parenteral) nutrition, from a broken thermometer, or from a suicide or homicide attempt.

As a rule, acute poisoning is more likely to result from inhalation or skin contact of dust, fumes or vapors, or materials in the workplace. However, lesser levels of contamination may occur in residential settings, particularly in older homes with lead paint or old plumbing (International Occupational Safety and Health Information Centre 1999). The Agency for Toxic Substances and Disease Registry (ATSDR) in Atlanta, Georgia, (a part of the U.S. Department of Health and Human Services) was established by congressional mandate to perform specific functions concerning adverse human health effects and diminished quality of life associated with exposure to hazardous substances.

The ATSDR is responsible for assessment of waste sites and providing health information concerning hazardous substances, response to emergency release situations, and education and training concerning hazardous substances (ATSDR Mission Statement, November 7, 2001). In cooperation with the U.S. Environmental Protection Agency, the ATSDR has compiled a Priority List for 2001 called the "Top 20 Hazardous Substances." The heavy metals arsenic, lead, mercury, and cadmium appear on this list.

## **CHAPTER 3**

### **MATERIAL & METHOD**

#### **3.1 Introduction**

The methodology of the research is discussed in this chapter. The main focus in this research is on adsorption gel that is created by saponified with saturated calcium hydroxide solution. To identify the percentage of metal uptake by SOW cake, two parameter is set up which are pH level and different simulated heavy metal ion solution. This process is divided into four main processes, which are preparation of the adsorption gel, preparation of H<sup>+</sup>-form SOW gel, and incubation process and adsorption analysis.

#### **3.2 Stage of Experimental**

Figure 3.1 show the flow diagram of overall process that has been throughout of this thesis. They are another 3 step to complete the preparation of the adsorption gel include mixing and milling process, filtration and drying process. The same 3 step in first preparation of SOW cake will be used in preparation of H<sup>+</sup>-form SOW gel. In incubation process, the solution of metal ion simulated need to separated with different pH using titration. And finally, adsorption analysis for the solution of metal ion simulated using AAS.

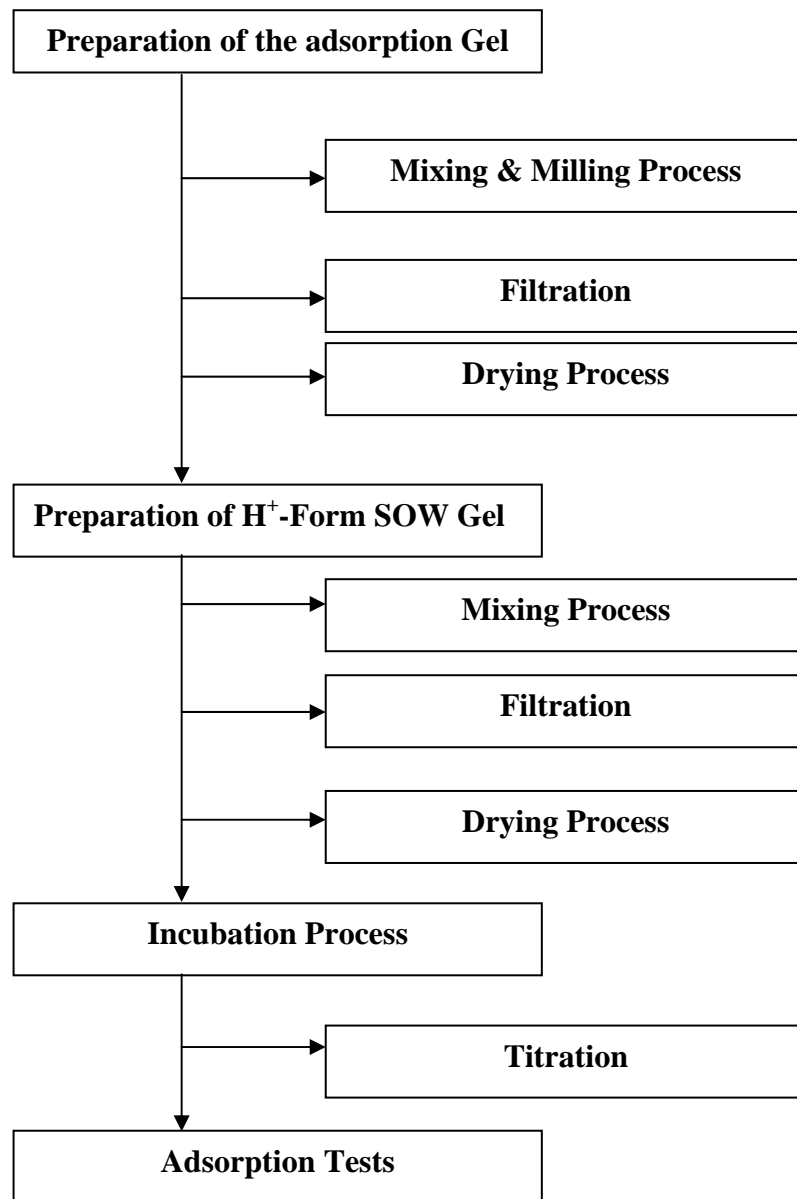

**Figure 3.1: Stage of Experimental**

### 3.3 Preparation of the adsorption gel from orange juice residue

100 g of crude orange waste was mixed together with 500 cm<sup>3</sup> of saturated calcium hydroxide solutions and crushed into fine particles using National model MJ-140K juice mixer (Calcium hydroxide not only facilitates the saponification but also enables to bleach out chlorophyll pigments and other low molecular weight compounds that hinder the adsorption). The suspension of saponified gel was repeatedly washed with distilled water followed by decantation until neutral pH and finally filtered. The wet cake of the saponified gel, which is abbreviated as SOW gel here after, was dried in a convection oven at 70 °C for 48 h.



**Figure 3.2: Drying Process in convection oven.**

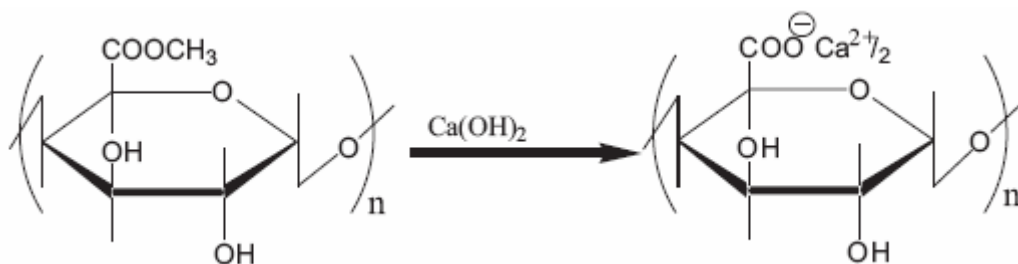

**Figure3.3. Methyl ester groups were saponified with saturated calcium hydroxide solution to convert them into carboxyl groups.**

### 3.4 Preparation of H<sup>+</sup>-form SOW gel

SOW wet cake, originally in the Ca<sup>2+</sup>-form, was converted into the H<sup>+</sup>-form by washing with 0.1 M hydrochloric acid solution for 2 h and further washed to neutral pH with deionizer water, followed by decantation, and then filtration. The obtained wet H<sup>+</sup>-form gel was dried in a convection oven at 70 °C for 24 h. [9]

### 3.5 Incubation Process

All adsorption tests of metal ions were carried out by the conventional batch method using aqueous test solutions containing single metal ions (The pH of the aqueous solutions was adjusted as described earlier). The flask, containing 0.1 g (dry weight) adsorption gel and 60 cm<sup>3</sup> test solution, was shaken vigorously in an incubator shaker maintained at 30 °C for 24 h to attain equilibrium. [9]



**Figure 3.4 Incubation Process.**

### **3.6 Absorption Analysis**

The metal concentrations before and after the adsorption for each metal ion solution were measured by using atomic absorption spectrophotometer. The percentage of adsorption (R %), defined as the ratio of decrease in concentration in metal ion solution before and after adsorption ( $C_o - C_c$ ) to its initial concentration ( $C_o$ ), was calculated according to equation, (1)

$$R = \frac{(C_o - C_c)}{C_o} \times 100 \quad (1)$$



**Figure 3.5: Absorption Analysis (AAS).**

## CHAPTER 4

### RESULTS AND DISSICUSION

#### 4.1 Adsorptive removal of metal ions



**Figure 4.1: SOW Cake**

Figure 4.1 shows an adsorbent that has been create by simple chemical modification techniques using saponification process. The SOW cake is in form of small partical. Fig. 4.2 shows the effect of equilibrium pH on the adsorption of various metal ions by the  $\text{Ca}^{2+}$ -form SOW. Adsorption increases with increasing pH. Together with the fact that the pH decreased after adsorption in all cases in this experiment, this result suggests that uptake of metal ions takes place according to a cation exchange mechanism. The selectivity order for various metal ions tested is as follows:  $\text{Pb (II)} > \text{Cd (II)} > \text{Zn (II)} > \text{Mn (II)}$ , while adsorption of  $\text{Pb (III)}$  is the



highest at  $\text{pH} > 4$ . Moreover, the selectivity preferences of Pb (II), Cd (III) and Zn (II) on the gel clearly show that they could be easily separated from the rest of these cationic species and lowering the pH of the test solution could offer easier Pb (II) ion separation.

SOW cake $\text{Ca}^{2+}$ -form				
(% Adsorption)				
pH	Zn (II)	Pb (II)	Mn (II)	Cd (II)
1	31.2	5	0	48
2	20	70.4	0	37.8
3	24	80	19.2	39.8
4	58.2	83	22	75.4
5	64.2	78.4	32	71.8
6	59.4	82.2	28.5	75.4
7	56.2	84	38.4	78.8

**Table 4.1: Result of Analysis from AAS for  $\text{Ca}^{2+}$ -Form SOW Cake**

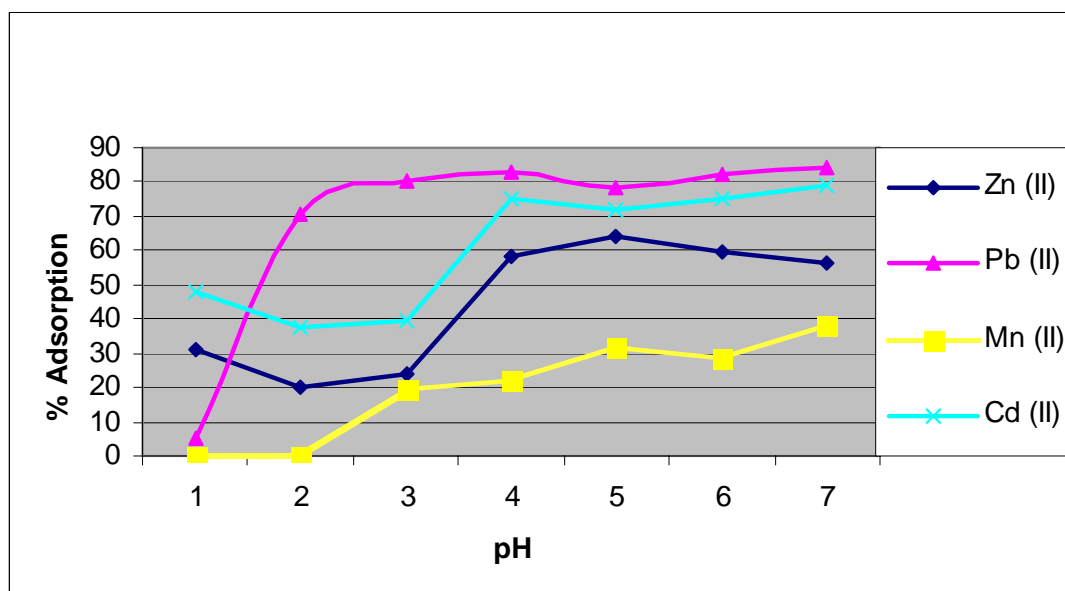

**Figure 4.2: Removal of Some Metal Ion on the  $\text{Ca}^{2+}$ -form SOW as a Function of Equilibrium pH. Weight of the Gel = 0.1 g. Volume of the Simulated Waste Water = 60 ml. Initial Metal Concentration = 5 ppm**

Fig 4.3 shows the effect of equilibrium pH on the adsorptive removal of the same metal ions with the H<sup>+</sup>-form SOW gel, where the selectivity order is Pb (II) > Cd (II) > Zn (II) > Mn (II) at low pH. From the graph show that plumbum can totally remove from the solution at pH >3. The experiments have approved SOW cake can be an adsorbent for heavy metal solution.

Fig. 4.2 and fig. 4.3 not only demonstrate the high selectivity of the gel for some metal ions, particularly for Pb(II), Cd (III) and Zn (II) but also show a low working pH range for these metal ions, compared with conventional weakly acidic cation exchange resins containing the same functional group, i.e. the carboxyl group. As mentioned earlier, the main chemical species of those gels responsible for metal ion uptake is either pectic acid or calcium pectate.

The adsorption of all metal ions appears to take place according to a Langmuir-type adsorption. That is, the adsorption increases with increasing metal ion concentration at low metal ion concentration while it tends to approach a constant value corresponding to each metal ion at high metal ion concentration. The maximum loading capacity was evaluated from these constant values. The higher value for Pb(II) can be attributed to the additional effects of precipitation with hydrochloric acid, the added driving force for the cation exchange mechanism.

Comparison of the loading capacity for divalent metal ions with the amount of the exchangeable cations of the H<sup>+</sup>-form SOW gel suggests that two carboxylic groups, the functional groups containing exchangeable cations, take part in the complexation with each of divalent metal ion according to the cation exchange mechanism proposed in the following section.

SOW Cake H <sup>+</sup> - form				
(% Adsorption)				
pH	Zn (II)%	Pb (II)%	Mn (II)%	Cd (II)%
1	27.6	0	0	37.8
2	25.2	94.4	0	36.4
3	65	100	31.8	83.2
4	70.8	100	36	88
5	71	100	36.6	92.2
6	72.8	100	35	88.6
7	74.8	100	51.8	90

**Table 4.2: Result of Analysis from AAS for H<sup>+</sup>-Form SOW Cake**

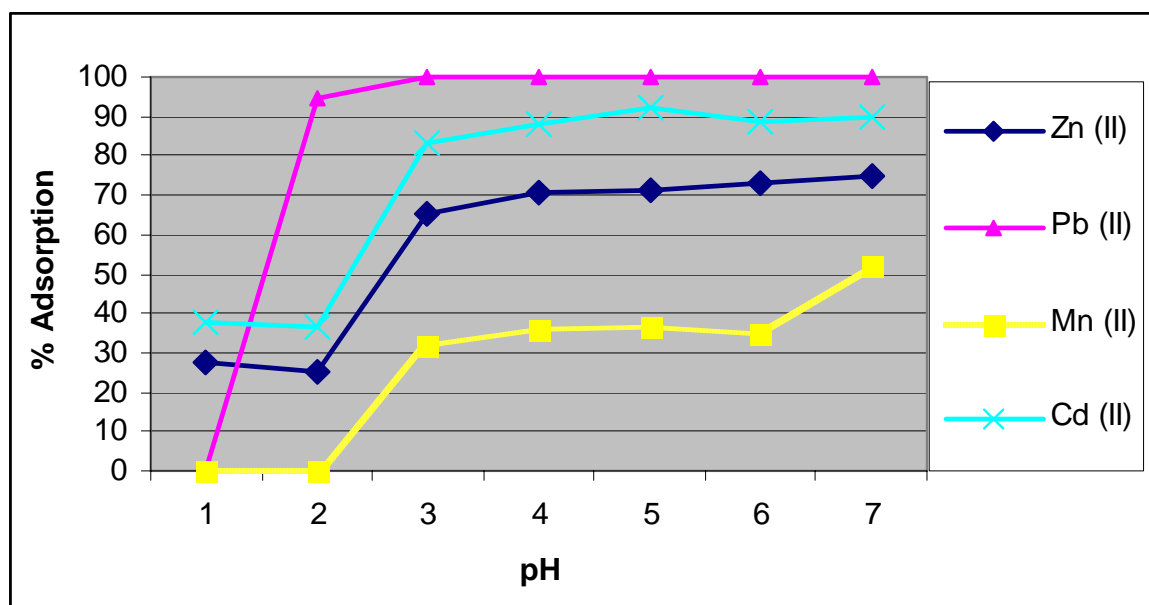

**Figure 4.3: Removal of Some Metal Ion on the H<sup>+</sup>-form SOW as a Function of Equilibrium pH. Weight of the Gel = 0.1 g. Volume of the Simulated Waste Water = 60 ml. Initial Metal Concentration = 5 ppm**

## 4.2 Adsorption mechanism

From the experimental results described in the preceding sections that 1) the adsorption of metal ions increases with increasing pH, 2) the pH in the simulated solution decreases after adsorption, and 3) two carboxylic group were involved for each divalent cation for complexation, it can be concluded that the adsorption of metal cations takes place according to a cation exchange mechanism releasing hydrogen ions from the carboxylic functional groups of pectic acid, the major constituent of the gel, as shown in fig 12.[6]

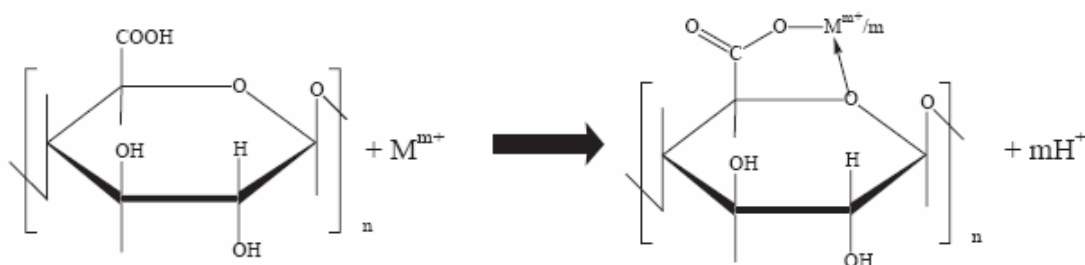

**1.1 Figure 4.3: Adsorption Mechanism of Metal Cation on Pectic Acid, a Major Constituent of the SOW Gel.**

## CHAPTER 5

### CONCLUSIONS AND RECOMMENDATIONS

#### 5.1 Conclusion

This study clearly suggests that simple chemical modification using calcium hydroxide converts the valueless biomass waste derived from orange wastes to a useful and environmental friendly adsorption gel. Such saponified orange waste, SOWgel, was found to be stable enough against dissolution in an aquatic environment and equally good as existing commercial ion exchange resins for removing toxic metal ions from the aquatic environment.

In addition, the gel also exhibited that favorable separation for some metal ions like Pb(II), Fe(III), and Cu(II) away from other metals can be achieved due to its high selectivity. Taking account of its efficiency, cost and benign behavior towards the environment, the SOW gel could be considered as an alternative adsorbent instead of conventional adsorption gels or resins to separate metal ions from the aquatic environment. Moreover, recovery of the metal ions using this gel would be expected to be easier and more economical compare to membrane.

## 5.2 Recommendations

### 5.2.1 Proposal for the post-treatment of the metal-loaded gel;

Usually, the post-treatment of the used gels or resins raise serious concerns for the environmentalist because of unsuitable disposal requirements. However, the metal-loaded SOW gel, could offer some options for such treatment as follows.

- 1) Elution of the loaded metal ions using strong acid: Similar to conventional cation exchange resins, loaded metal ions can be eluted at high concentration with strong acid according to the cation exchange mechanism. Metal-free adsorption gels after elution can be reused for further adsorption of metals. But, unlike ion exchange resins, the adsorption gel prepared from biomass is not expected to be sufficiently robust or strong for many repeat cycles of adsorption–elution.
  
- 2) Incineration of metal-loaded gel: Adsorption gels prepared from biomass wastes consisting of polysaccharides have another advantageous characteristic making the post-treatment much easier compared with ion exchange resins made of plastics and refractory materials. That is easy incineration. The metal-loaded gel can be treated as feed materials at non-ferrous metals smelters for Cu(II), Zn(II) and Ni(II) together with the metal concentrates. Or, the gels also can be treated in incineration plants of industrial waste where the gel is incinerated together with other metal-containing industrial wastes. After incineration, the majority of metals remain in the fly ash which can be collected by using bag filters or electric metal-loaded. The collected fly ash can be sold to non-ferrous metal smelters as feed material as has been currently carried out.

3) Decomposition of polymer matrices of biomass containing metal ions: Polymer matrices of biomass can be decomposed by using super critical water or by microorganisms which are currently in extensive use for the treatments of garbage by bio decomposition. After the decomposition of the polymer matrices into water and carbon dioxide, the loaded metal ions are left in water at high concentration that can be sold also to non-ferrous metal smelters as feed materials. [9]

## REFERENCES

1. Rabindra Prasad Dhakal, Kedar Nath Ghimire, Katsutoshi Inoue (2004) "Adsorption Separation of Heavy Metals from an Aquatic Environment using Orange Waste". Saga University, Japan
2. A.V. Jamode, M. Rao, B.S Chandak, V.S. Jamode and A.V. Parwate, Application of the inexpensive adsorbents for the removal of heavy metals from industrial waste water, a brief review, *J. Ind. Pollut. Control* **19** (2003) (1), pp. 114–134
3. A. Hussein, Mahvi, D. Naghipour, F. Vaezi and S. Nazmara, Tea waste as an adsorbent for heavy metal removal from industrial wastewaters, *Am. J. Appl. Sci.* **2** (2005) (1), pp. 372–375.
4. H.S.F.V. Regine and V. Boya, Biosorption: a solution to pollution?, *Int. Microbiol.* **3** (2000), pp. 17–24
5. M. Yano and K. Inoue, Adsorption of metal on alginic acid amide, pectic acid amide, cross linked pectic acid and crosslinked alginic acid, *Anal. Sci.* **13** (1997), pp. 359–360 (Suppl.).
6. R.P. Dhakal, K.N. Ghimire, K. Inoue, M. Yano and K. Makino, Acidic polysaccharide gels for selective adsorption of lead(II) ion, *Sep. Purif. Technol.* **42** (2005), pp. 219–225
7. M. Yano, K. Inoue, K. Makino and Y. Baba, *Kankyokagakukaishi (Japanese)* **14** (2001), pp. 345–349.
8. R.J. Crawford, D.E. Mainwaring and I.H. Harding, Adsorption and coprecipitation of heavy metals from ammoniacal solutions using hydrous metal oxides, *Colloids Surf., A Physicochem. Eng. Asp.* **126** (1997), pp. 167–179
9. Rabindra Prasad Dhakal, Kedar Nath Ghimire, Katsutoshi Inoue (2004) "Adsorption Separation of Heavy Metals from an Aquatic Environment using Orange Waste". Saga University, Japan
10. Department of Geology, Colgate University, 13 Oak Drive Hamilton, NY 13346



11. Christie John geankoplis “Transport process and separation process principle” fourth edition. Pp 760-763
12. Lenntech Water treatment & air purification Holding B.V. Rotterdamseweg 402 M
13. Akta Kualiti Alam Sekeliling 1974(Akta 127), Lembaga Penyelidikan Undang-Undang 2005.’International Law Book Series’. Pp 122

**APPENDIX A**

Data from AAS for Calcium form

ELEMENT: Pb

<b>Sample ID</b>	<b>Conc</b>	<b>RSD(%)</b>	<b>ABS</b>	<b>REF</b>
<b>STD1</b>	0.00	-366.67	-0.0003	-0.0231
<b>STD2</b>	0.40	383.33	0.0006	-0.0380
<b>STD3</b>	0.80	2.48	0.0121	-0.0570
<b>STD4</b>	1.20	2.67	0.0150	-0.0671
<b>UNK-001</b>	4.75	1.05	0.0663	-0.0714
<b>UNK-002</b>	1.48	0.68	0.0195	-0.0813
<b>UNK-003</b>	1.00	3.23	0.0119	-0.0942
<b>UNK-004</b>	0.85	2.35	0.0104	-0.0921
<b>UNK-005</b>	1.08	4.63	0.0136	-0.0965
<b>UNK-006</b>	0.89	1.12	0.0109	-0.0991
<b>UNK-007</b>	0.80	2.50	0.0097	-0.1028

**APPENDIX B**

Data from AAS for Calcium form

ELEMENT: Zn

<b>Sample ID</b>	<b>Conc</b>	<b>RSD(%)</b>	<b>ABS</b>	<b>REF</b>
<b>STD1</b>	0.00	-55.17	-0.0058	0.0096
<b>STD2</b>	0.40	1.83	0.2405	0.0338
<b>STD3</b>	0.80	2.87	0.3412	0.0435
<b>STD4</b>	1.20	0.50	0.4775	0.0586
<b>UNK-001</b>	3.44	0.29	1.3615	0.1828
<b>UNK-002</b>	4.00	5.50	1.5807	0.3003
<b>UNK-003</b>	3.79	3.43	1.4997	0.2146
<b>UNK-004</b>	2.09	0.48	0.8415	0.1004
<b>UNK-005</b>	1.79	0.56	0.7230	0.0841
<b>UNK-006</b>	2.03	0.49	0.8166	0.0928
<b>UNK-007</b>	2.19	2.74	0.8806	0.1012

**APPENDIX C**

Data from AAS for Calcium form

ELEMENT: Cd

<b>Sample ID</b>	<b>Conc</b>	<b>RSD(%)</b>	<b>ABS</b>	<b>REF</b>
<b>STD1</b>	0.00	****	0.0000	-0.0119
<b>STD2</b>	0.40	0.26	0.1173	-0.0226
<b>STD3</b>	0.80	0.40	0.1750	-0.0311
<b>STD4</b>	1.20	0.05	0.2095	-0.0426
<b>UNK-001</b>	2.60	0.00	0.4685	0.0079
<b>UNK-002</b>	3.11	0.32	0.5549	0.0417
<b>UNK-003</b>	3.01	0.33	0.5381	0.0270
<b>UNK-004</b>	1.23	1.37	0.1480	-0.0844
<b>UNK-005</b>	1.41	1.10	0.1776	-0.0828
<b>UNK-006</b>	1.23	1.37	0.1472	-0.0933
<b>UNK-007</b>	1.06	0.00	0.1187	-0.1018

**APPENDIX D**

Data from AAS for Calcium form

ELEMENT: Mn

Sample ID	Conc	RSD(%)	ABS	REF
<b>STD1</b>	0.00	-16.67	-0.0006	-0.0060
<b>STD2</b>	0.40	0.74	0.0809	-0.0122
<b>STD3</b>	0.80	0.08	0.1183	-0.0203
<b>STD4</b>	1.20	0.08	0.1221	-0.0277
<b>UNK-001</b>	5.20	0.77	0.5459	-0.0119
<b>UNK-002</b>	5.96	0.00	0.6237	-0.0121
<b>UNK-003</b>	4.04	0.99	0.4284	-0.0258
<b>UNK-004</b>	3.90	0.77	0.4148	-0.0317
<b>UNK-005</b>	3.40	0.29	0.3640	-0.0378
<b>UNK-006</b>	3.59	0.28	0.3828	-0.0406
<b>UNK-007</b>	3.08	2.92	0.3307	-0.0469

**APPENDIX E**

Data from AAS for hydrogen form

ELEMENT: Mn

<b>Sample ID</b>	<b>Conc</b>	<b>RSD(%)</b>	<b>ABS</b>	<b>REF</b>
<b>STD1</b>	0.00	-16.67	-0.0006	-0.0060
<b>STD2</b>	0.40	0.74	0.0809	-0.0122
<b>STD3</b>	0.80	0.08	0.1183	-0.0203
<b>STD4</b>	1.20	0.08	0.1221	-0.0277
<b>UNK-001</b>	5.27	0.19	0.5510	-0.0733
<b>UNK-002</b>	5.79	0.17	0.6065	-0.0709
<b>UNK-003</b>	3.41	0.29	0.3651	-0.0843
<b>UNK-004</b>	3.20	0.31	0.3441	-0.0864
<b>UNK-005</b>	3.17	0.32	0.3406	-0.0874
<b>UNK-006</b>	3.25	0.00	0.3487	-0.0873
<b>UNK-007</b>	2.41	1.24	0.2635	-0.0921

**APPENDIX F**

Data from AAS for hydrogen form

ELEMENT: Cd

<b>Sample ID</b>	<b>Conc</b>	<b>RSD(%)</b>	<b>ABS</b>	<b>REF</b>
<b>STD1</b>	0.00	100.00	0.0001	-0.0001
<b>STD2</b>	0.40	0.32	0.0930	0.0165
<b>STD3</b>	0.80	0.21	0.1411	0.0263
<b>STD4</b>	1.20	0.56	0.1783	0.0338
<b>UNK-001</b>	3.11	0.32	0.4683	0.1194
<b>UNK-002</b>	3.18	0.00	0.4792	0.1259
<b>UNK-003</b>	0.84	1.19	0.1375	0.0248
<b>UNK-004</b>	0.60	0.00	0.1032	0.0178
<b>UNK-005</b>	0.39	0.00	0.0726	0.0122
<b>UNK-006</b>	0.57	0.00	0.0984	0.0172
<b>UNK-007</b>	0.50	0.00	0.0887	0.0160

**APPENDIX G**

Data from AAS for hydrogen form

ELEMENT: Pb

<b>Sample ID</b>	<b>Conc</b>	<b>RSD(%)</b>	<b>ABS</b>	<b>REF</b>
<b>STD1</b>	0.00	150.00	0.0002	-0.0004
<b>STD2</b>	0.40	2.20	0.0091	-0.0018
<b>STD3</b>	0.80	0.80	0.0125	-0.0042
<b>STD4</b>	1.20	2.41	0.0166	-0.0051
<b>UNK-001</b>	5.98	1.34	0.0804	-0.0011
<b>UNK-002</b>	0.28	21.43	0.0054	-0.0088
<b>UNK-003</b>	0.00	-100.00	0.0017	-0.0100
<b>UNK-004</b>	0.00	-100.00	0.0017	-0.0100
<b>UNK-005</b>	0.00	-100.00	0.0017	-0.0100
<b>UNK-006</b>	0.00	-100.00	0.0017	-0.0100
<b>UNK-007</b>	0.00	-100.00	0.0017	-0.0100



**APPENDIX H**

Data from AAS for hydrogen form

ELEMENT: Zn

<b>Sample ID</b>	<b>Conc</b>	<b>RSD(%)</b>	<b>ABS</b>	<b>REF</b>
<b>STD1</b>	0.00	65.63	0.0032	0.0037
<b>STD2</b>	0.40	0.71	0.2546	0.0248
<b>STD3</b>	0.80	0.44	0.3665	0.0380
<b>STD4</b>	1.20	1.50	0.4534	0.0508
<b>UNK-001</b>	3.62	0.28	1.3721	0.1960
<b>UNK-002</b>	3.74	3.21	1.4148	0.2186
<b>UNK-003</b>	1.75	2.29	0.6885	0.0702
<b>UNK-004</b>	1.46	4.11	0.5841	0.0605
<b>UNK-005</b>	1.40	2.10	0.0036	0.0580
<b>UNK-006</b>	1.36	0.74	0.5471	0.0525
<b>UNK-007</b>	1.26	0.79	0.5109	0.0515