



2nd International Conference on Sustainable Energy Engineering and Application, ICSEEA 2014

Design of single acting pulley actuator (SAPA) continuously variable transmission (CVT)

Nur Cholis^{a,*}, Sugeng Ariyono^b, Gigih Priyandoko^c

^aNational Institute of Science & Technology (ISTN), Jl. Moh. Kahfi II Jagakarsa, Jakarta Selatan 12640, Indonesia

^bSemarang State Polytechnic (Polines), Jl. Prof. H. Soedarto, SH, Tembalang Semarang 50275, Indonesia

^cUniversiti Malaysia Pahang (UMP), 26600 Pekan, Pahang Darul Makmur, Malaysia

Abstract

The design of Single Acting Pulley Actuator (SAPA) Continuously Variable Transmission (CVT) utilizes combinations of DC motor system, gear reducers and power cam mechanisms to actuate primary movable pulley sheaves on the transmission shaft. The secondary pulley supported by spring provides a belt clamping force to prevent slips, while the secondary controls the rubber v-belt from slipping. Since the methods of controlling these are similar, this paper only discusses the primary part. The servomotor regulates the axial movement of primary movable pulley sheaves to shift the rubber v-belt placed between the sheaves, and change the belt-pulley contact radius. Changing this contact radius means changing the CVT ratio. Computer simulation results are presented to demonstrate the effectiveness of the proposed PD controller. The research outcome gives a significant result to complete 75.08° rotation of the CAM from lower gear ratio to top gear ratio is less than 6.79 sec, with minimum error and less overshoot with a manual PD tuning contribution to the field of DC motor based electro-mechanical CVT control system.

© 2015 The Authors. Published by Elsevier Ltd. This is an open access article under the CC BY-NC-ND license

(<http://creativecommons.org/licenses/by-nc-nd/4.0/>).

Peer-review under responsibility of Scientific Committee of ICSEEA 2014

Keywords: continuously variable transmission; power cam mechanisms; clamping force; contact radius

* Corresponding author. Tel.: +62-21 7270091; fax: +62-21 7874964.

E-mail address: nr.chls@gmail.com

1. Introduction

In the last decades, V-belt CVT (Continuously Variable Transmission) is a transmission having a speed ratio that can be varied continuously over its allowable speed range. Its speed ratio may take on any value between its operational limit, i.e. An infinite number of ratios are possible. A gearbox transmission, on the other hand, has a discrete number of fixed speed ratios. This property of the V-belt CVT gives a better fuel economy compared with that of classical gearbox transmission. Besides, the V-belt CVT has many advantages such as compact, light weight, low manufacturing cost because it has a relatively small number of parts [1]. The rubber V-belt continuously variable transmission (CVT) has been widely used in low-power vehicles such as snowmobiles and scooters because of its significant advantages over other transmissions, including its simple construction, smooth operation, easy drivability, low cost, easy maintenance, etc. CVTs allow the engine to operate near maximum power point by automatically varying speed, so theoretically, rubber V-belt CVTs have an economic efficiency advantage over other transmissions [2]. However, in spite of the several advantages proposed by a CVT system, the goals of higher fuel economy and better performance have not been realized significantly in a real production vehicle. In order to achieve lower emissions and better performance, it is necessary to capture and understand the detailed dynamic interactions in a CVT system so that efficient controllers could be designed to overcome the existing losses and enhance the fuel economy of a vehicle [3]. To overcome this energy loss, the electromechanical actuated CVT system becomes a viable solution, since this system only operates during changing the transmission ratio. The electromechanical actuated CVT with a single acting pulley system was introduced in [4]. PID controller is suitable for fixed parameters processes that could be mathematically modeled using linear first or second order systems. However, an accurate model of a real industrial process is difficult to obtain, since the process itself may have complex characteristics such as nonlinearity, high order, delay-time, dead-time, etc. That cannot be easily modeled using a simple linear system [5]. In addition, the process may be affected by parameter variations due to temperature, ageing components, noise, and load disturbance. For these complex processes, tuning laws based on these inaccurate models are no longer adequate to attain the controller gains properly. PID (Proportional, Integral and Derivative) controller has been the basis in simple linear control systems. It is a well-known and well-established technique for various industrial control applications. This is mainly due to its simple design, straight forward parameters tuning and robust performance. As actuators, DC servomotors are extensively used in many automatic controls, including drive for robotic manipulators, machine tools, rolling machines, photocopy machines etc. PID controllers are usually used to control these servomotors. Position controls utilizing PID can be seen in [6],[7],[8],[9],[10]. To design an effective PID controller, three gain parameters, namely, proportional gain, integral gain and derivative gain need to be specified accordingly. The conventional approach to determine the PID parameters is to study the mathematical model of the process and try to come up with a simple tuning law that provides a fixed set of gain parameters. One example of such approach is the Ziegler-Nichols method [11]. This paper uses PID controller and introduces the Single Acting Pulley Actuator Continuously Variable Transmission (SAPA CVT) ratio control with one DC motor as its actuators. This actuator works only during transmission ratio changes, hence shortening actuator's operation time and reducing energy loss. The section headings are arranged by numbers, bold and 10 pt. Here follows further instructions for authors.

2. Background of CVT

A basic CVT works just like a variator. It consists of a primary pulley, a secondary pulley and a rubber V-belt connecting these two pulleys. Each of driver and driven pulley consists of a fixed and a movable pulley is given in fig. 1.(a). The fixed pulleys are fixed on the shafts and the movable pulleys are able to move in the axial direction on the shafts. Continuously variable transmission can be achieved by control of the pulley axial distance between the fixed and the movable pulleys. If the movable pulley of the driver shaft is moved towards the fixed pulley, the V-belt is forced to be pushed in the radial outward direction, which causes the belt pitch diameter to increase. Since the belt length and the center distance between the shafts are fixed, the belt pitch diameter of the driven pulley decreases. Therefore, the speed ratio decreases in a continuous manner. The variator geometry is given in Fig. 1.(b).

Transmission mechanism of the conventional V-belt CVT is shown on Fig. 2.(a). Each of driver and driven pulley consists of a fixed and a movable pulley. The fixed pulleys are fixed on the shafts and the movable pulleys are able

to move in the axial direction on the shafts. Continuously variable transmission can be achieved by control of the pulley axial distance between the fixed and the movable pulleys. If the movable pulley of the driver shaft is moved towards the fixed pulley, the V-belt is forced to be pushed in the radial outward direction, which causes the belt pitch diameter to increase. Since the belt length and the center distance between the shafts are fixed, the belt pitch diameter of the driven pulley decreases. Therefore, the speed ratio decreases in a continuous manner.

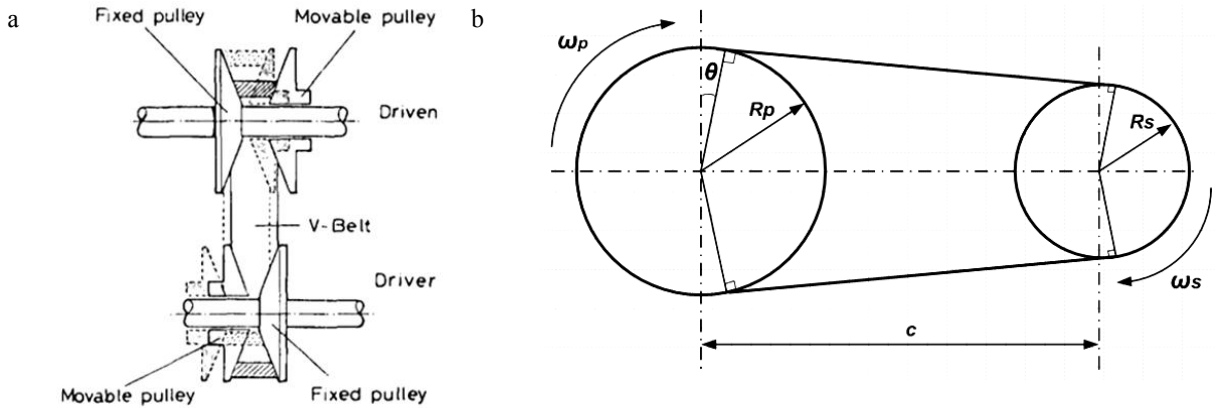

Fig. 1.(a) Principle of a V-belt CVT; (b) Variator geometry.

Any desired speed ratio can be obtained by control of the pulley axial displacement. Since the pulley axial displacement is controlled by axial force on the driver and the driven pulleys, an accurate relationship between the speed ratio and the axial force is required to maintain an optimum driving condition. Also, the axial forces are directly related with the belt tension. If the belt tension and associated axial forces are kept only as high as necessary to prevent slip at all load levels, then an enormous improvement in belt life will result compared to tension set for maximum design power. Therefore, we can say that it is an integral part of the V-belt CVT design to obtain an accurate relationship between the axial force and torque load for given speed ratios.

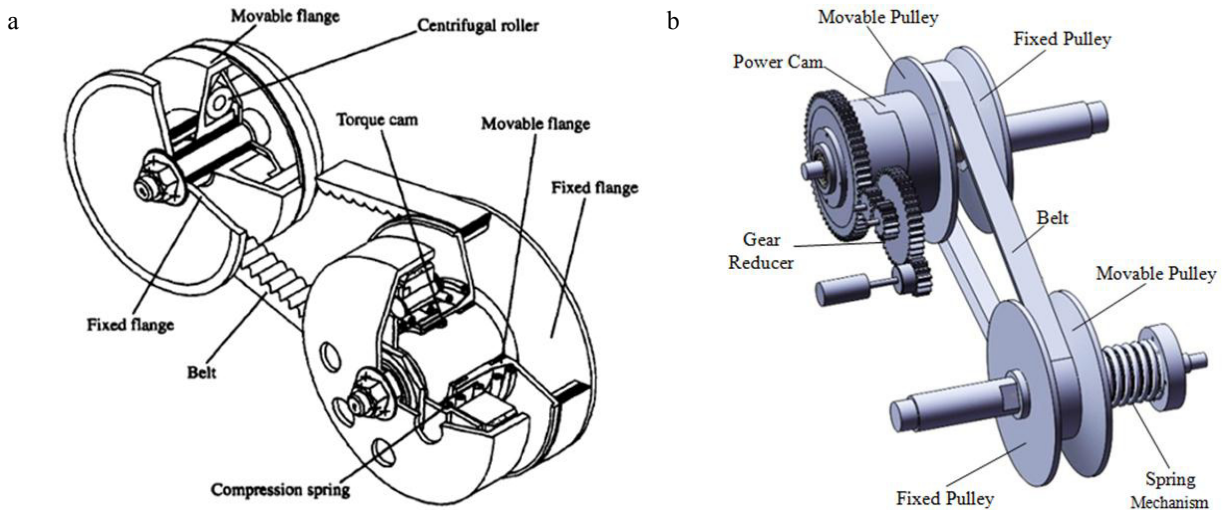

Fig. 2.(a) The conventional of CVT; (b) SAPA.

The Single Acting Pulley Actuator Continuously Variable Transmission (SAPA CVT) system utilizes servomotor as actuators is shown on Fig. 2(b). The system consists of two sets of pulleys, namely primary pulley placed on

input fixed shaft, and secondary pulley placed on secondary fixed shaft. Each set of pulley has two movable sheaves that can be shifted axially along the shaft. The primary motor actuates the primary pulley movement for transmission ratio change, while the spring mechanism actuates the secondary pulley movement for clamping force [12]. A spring disc is inserted in the back of each secondary pulley sheave to provide continuous clamping force to the belt, and to reduce excessive slip during transmission ratio change. When the CVT is on an under drive position, the primary belt radius is minimum while the secondary belt radius is maximum, the ratio change is called, the primary motor will actuate the primary pulley axially to the new value of primary radius, and at the same time the spring mechanism will actuate the secondary pulley axially to provide the optimal clamping force for preventing a belt slips [13]. These movements will stop if the desired ratio is achieved. When the CVT is on the overdrive position, the primary belt radius is maximal, while the secondary belt radius is minimal.

If belt has fixed length and rotates without slip, then both pulleys and belt will move at the same tangential velocities. The relationship between speed and running radii can be given as follows:

$$\omega_s R_s = \omega_p R_p \tag{1}$$

$$r_{cvt} = \frac{R_s}{R_p} \tag{2}$$

The implicit relationship between belt length and running radii can be defined as:

$$L = (\pi + 2\theta)R_p + (\pi - 2\theta)R_s + 2c \cos(\theta) \tag{3}$$

$$R_p = R_s + c \sin(\theta) \tag{4}$$

The relationship between running radii and pulley position can be given as:

$$x_p = (R_p - R_{p0}) \tan(\alpha) \tag{5}$$

$$x_s = (R_s - R_{s0}) \tan(\alpha) \tag{6}$$

By using equation (3) and (4), for c=260 mm, and L=853 mm, the relationship between running radii and belt wrapped angle, θ , is shown in Fig. 1.(b). By using equation (5), (6) and data from Fig. 3.(a). By varying CVT ratio from 0.9 up to 2.8, the relationship between pulley positions and CVT ratio can plotted in Fig. 3.(b).

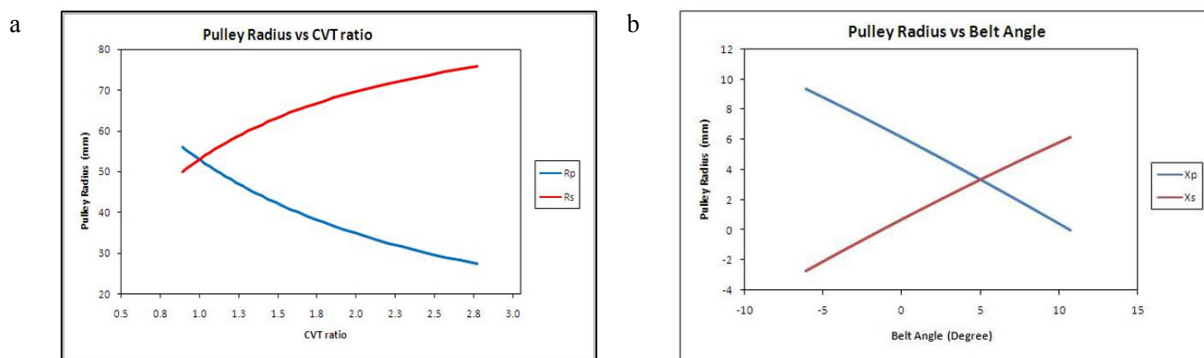

Fig. 3. (a) Relationship between running radii and belt wrapped angle; (b) Relationship between pulley positions and CVT ratio

3. Gear reducer and power cam mechanism

The gear reducers are coupled with the servomotor shaft is shown in Fig. 4, a gear reducer serves as a speed reducer and torque multiplier. The gear reducer output is connected to power cam mechanism for shifting the pulley sheaves. The power cam mechanism is used to move the pulley sheaves axially. The combination of gear reducers and power cam mechanism is used to help the motor in providing significant torque to turn the power cam mechanism. It converts every 360° of rotation into 2 millimeters axial movement. Therefore the motor have to turn 12.3 rev in order to turn 1 rev of the CAM. In order to turn 75.08° to expend the cam to limit, the motor have to turn 2.46 rev.

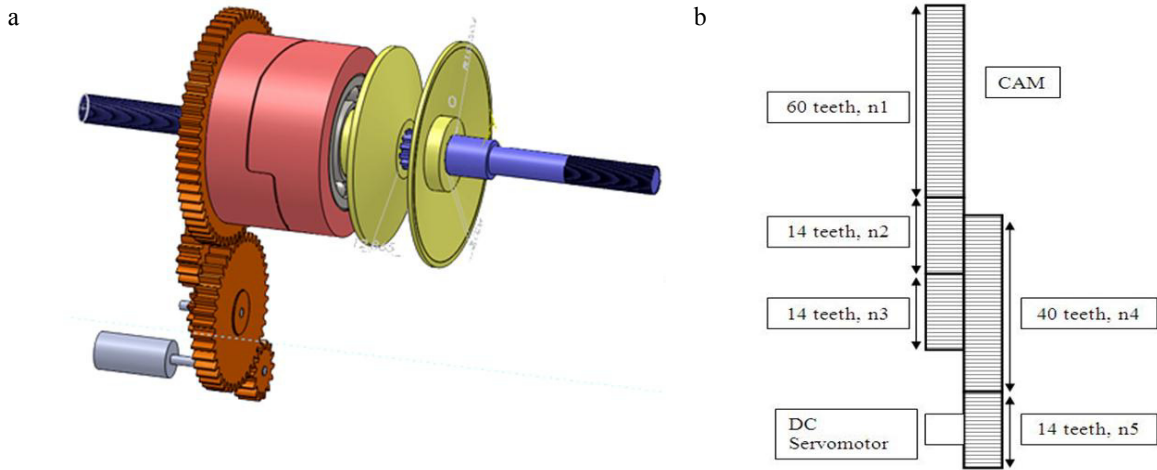

Fig. 4. (a) Gears Reducer; (b) Schematic of gears reducer.

The power cam mechanism set is the main mechanism for the movable pulley to move in X axis to change the diameter of the belt driver pulley, resulting in ratio change in the transmission. The CAM is control by a DC electric motor through a train of gears so that the torque for the CAM to rotate at high rpm can be step down is shown in Fig. 5(a). Therefore, Fig. 5(b) is shown the maximum rotation of the CAM 75.08° (α) and based on the design maximum X axis distance for male CAM to travel is 15mm. The rotation of the CAM will cause movement in X axis at moveable sheave of the driver pulley and the relation of the two motions is as follow.

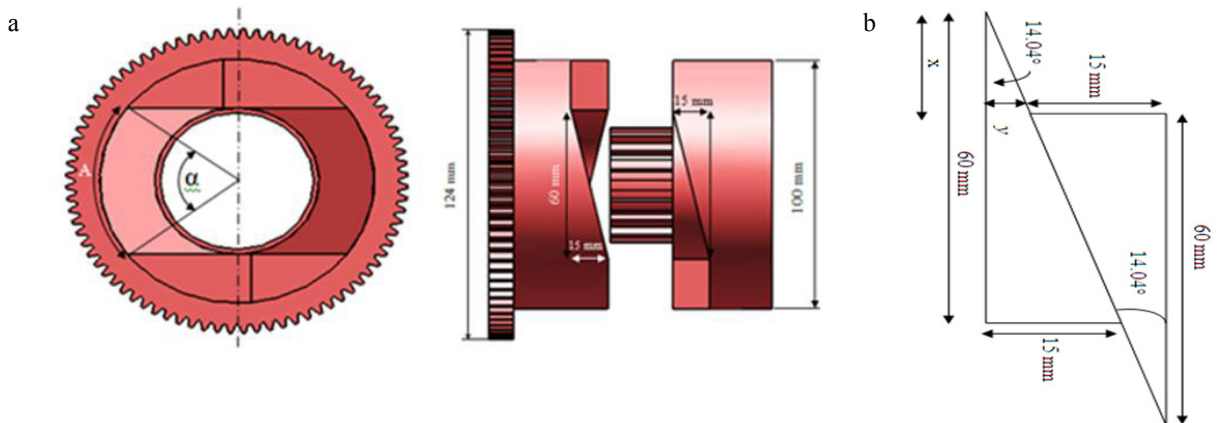

Fig. 5. (a) Power Cam Mechanism; (b) Schematic of power cam mechanism

4. Results and discussion

Simulation studies of the proposed PID controller are carried out in order to investigate its effectiveness in this position control application. In these studies, the DC servomotor has the following important parameters as shown in Table 1. The transfer function of a PID controller has the following form:

$$G_{PID} = K_p + K_i / s + K_d s \quad (7)$$

where K_p , K_i , and K_d are the proportional, integral, and derivative gains, respectively. Another useful equivalent form of the PID controller is given by:

$$G_{PID} = K_p (1 + 1/(T_i s) + T_d s) \quad (8)$$

where $T_i = K_p / K_i$ and $T_d = K_d / K_p$; T_i and T_d are the integral time constant and the derivative time constant, respectively. The tuning objective is to determine the suitable value of three parameters (K_p , K_i , and K_d) to satisfy certain control specifications. In order to obtain the initial parameters of PID controller, the Astrom-Hagglund method [25] will be used to determine the values of critical period of waveform oscillation (T_c) and critical gain (K_c). These two values could be obtained by running the closed loop control of DC servomotor system utilizing relay feedback as a controller. The oscillation period of the output waveform is considered as the critical period attained from a proportional feedback. Based on this critical period (see Fig. 11), the critical gain can be derived as follow:

$$K_c = \frac{4d}{\pi a} \quad (9)$$

where d is the amplitude of the relay output, and a is the amplitude of the waveform oscillation.

Based on these two values, the PID parameters (K_p , T_i , and T_d) can be specified using Ziegler-Nichols formula (see Table 2).

Table 1. DC servomotor parameters.

Parameters	Values
Motor Voltage	24 V
Inductance	0.0228
Resistance	1.0564
Back emf Constant	0.22052
Torque Constant	0.22052
Rotor Inertia	7.e-5
Friction Coefficient	0.00191

Table 2. Ziegler-Nichols parameter tuning.

	K_p	T_i	T_d
P	0.5 K_c		
PI	0.45 K_c	0.85 T_c	
PID	0.6 K_c	0.5 T_c	0.125 T_c

Based on these parameters, the simulation of the system was investigated. The simulation of the controller was performed using Matlab-Simulink packages. Control performance is determined based on percent overshoot, settling

time (t_s), and steady state error (e_{ss}). Two types of input excitation: step and sinusoidal waveform are used to examine the performance of the conventional PID.

In order to obtain initial parameters of PID, the Astrom-Hagglund method based on a relay feedback controller is carried out to attain the critical period of waveform oscillation (T_c) and critical gain (K_c). The relay feedback controller is used in a closed loop control application. The amplitude of the relay controller is set to 15 since the input voltage in the range of $[-24,+24$ volts] is needed to drive the servo system. From simulation results, these following parameters are found: $T_c=0.04$ s, $a = 0.0917$, and $d = 24$ (Fig. 6).

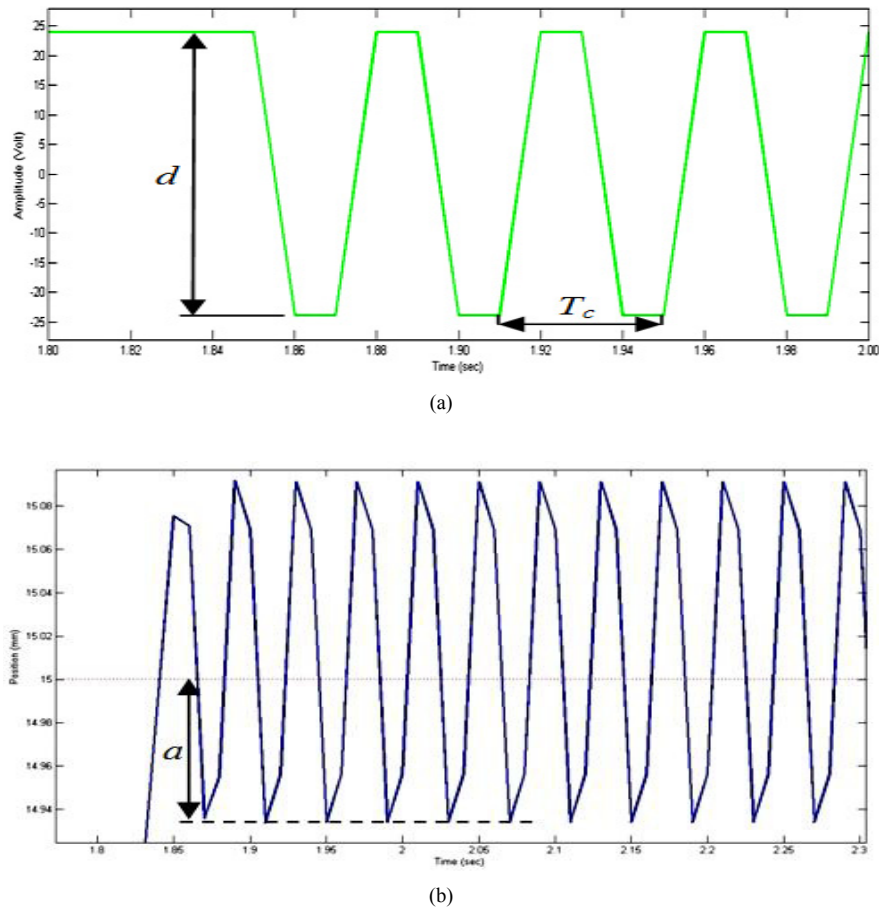

Fig. 6. The results of relay feedback controller (a) Relay output; (b) Waveform of oscillation

By using equation (9), the critical gain (K_c) is 333.405. Then, the Ziegler-Nichols formula (see table 2.) is applied to find the values of K_p , T_i , and T_d . Finally, by using these values and equations (7),(8), the three parameters of PID can be specified as follows: $K_p=200$, $K_i=10002$, and $K_d=1$. From these data, it can be seen that the value of the integral gain (K_i) is much bigger compare to other gains. By closely looking at the small amplitude of waveform oscillations, it can be seen that the servo system exhibits a small steady state error of about 1.3 % (for set-point = 15 mm). This condition can be understood, since the servo system utilizes gear reducers with a total gear set ratio of about (12.3:1) to supply pulley clamping force, hence slowing down the axial pulley movement significantly. Based on this fact, it is reasonable to say that the integral gain was not used for controlling this kind of servo system, since the system behavior has already had a small tolerable steady state error. PID controller variations are shown in the table 3.

Table 3. PID controller variations.

Tuning Method	Controller Type	K_p	K_i	K_d
Ziegler-Nichols	P	167	0	0
	PI	150	4413	0
	PID	200	10002	1

From table 3, it can be seen that the value of the integral gain (K_i) is much bigger compared to other gains. Based on the system behaviour performed during the relay feedback experiment, a small tolerable steady state error has occurred; therefore the integral gain is not used for controlling this kind of system because the use of big integral gain makes the system unstable.

Fig. 7.(a) shows the results of relay feedback experiment of the DC motor to actuate pulley axial position, long settling time up to 96s after all PID parameters are implemented to basic PID controller scheme, then settling time become 56s after reduce K_d . The smaller the integral gain, the better the system output response. The PD controller can be considered has a good performance in terms of percent overshoot, settling time less 1.98s and zero steady state error as shown in Fig. 7.(b).

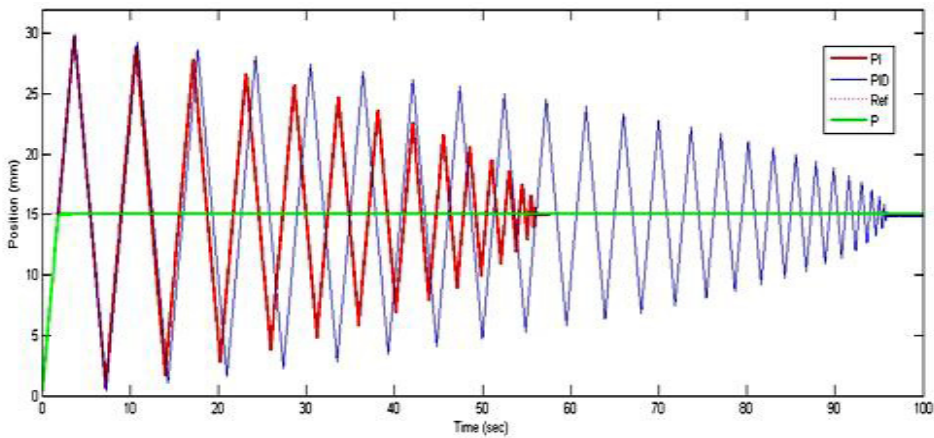

(a)

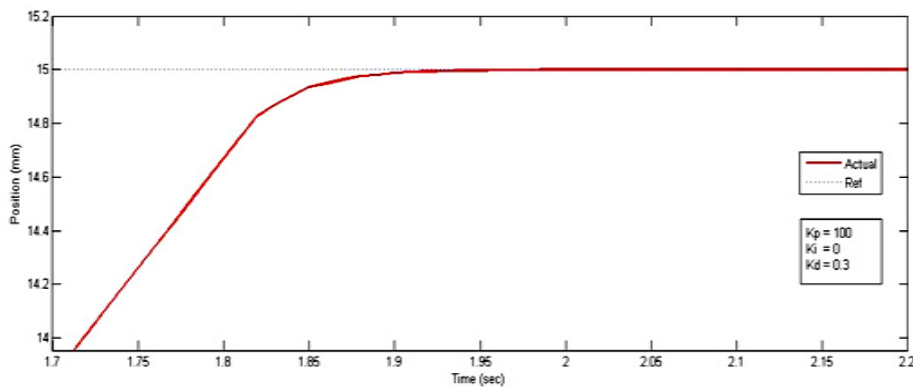

(b)

Fig. 7. (a) Response curve for PID controller variations; (b) Response curve for PD controller with manual tuning of $K_p=100$ & $K_d=0.3$

5. Conclusion

The simulation results has significantly improved the performance of the conventional PD controller to complete 75.08° rotation of the CAM from lower gear ratio to top gear ratio is less than 6.79 sec (CVT ratio from 0.9 up to 2.8), in terms of percent overshoot and steady state error, both controllers perform well for the Single Acting Pulley Actuator (SAPA) Continuously Variable Transmission (CVT) system utilizes.

Acknowledgements

The authors would like to thank National Institute of Science & Technology (ISTN), Semarang State Polytechnic (Polines) and Universiti Malaysia Pahang (UMP).

References

- [1] Kwangwon K and Hyunsoo K 1989 Axial forces of a V-belt CVT Journal of Mechanical Science and Technology vol 3 no 1 pp 56-61
- [2] Zhu C, Liu H and Tian J 2010 Experimental investigation on the efficiency of the pulley-drive CVT International Journal of Automotive Technology vol 11 no 2 pp 257-261
- [3] Nilabh S and Imtiaz H 2009 A review on belt and chain continuously variable transmissions (CVT): Dynamics and control, Mechanism and Machine Theory vol 44 no 1 pp 19-41
- [4] Van D M, Rosielle, Bonsen and Klaassen 2004 Design of An Electromechanical Ratio and Clamping Force Actuator for a Metal V-Belt Type CVT, 7th International Symposium on Advanced Vehicle Control (AVEC'04) Arnhem Netherland
- [5] Bambang S, Kamarul B T, Hishamuddin J and Sugeng A 2006 DC Motor Position Control for Pulley Axial Movement of an Electromechanical Dual Acting Pulley (EMDAP) CVT System, 1st Regional Conference on Vehicle Engineering & Technology, Kuala Lumpur Malaysia.
- [6] Shi J, Xu D, and Wang Z 2000 Hybrid Stepping Motor Position Servo System Based On DSP IECON 2000 20th Annual Conference of the IEEE Industrial Electronics Society IEEE Vol 2 pp1475-1479.
- [7] Habib, Maki, 2001 Designing Fuzzy Logic Controllers for DC Servomotors Supported by Fuzzy Logic Control Development Environment In IECON'01: The 27th Annual Conference of the IEEE Industrial Electronics Society
- [8] Yu Y, Wen G W, De J Y and Ge D 2002 A Fuzzy Parameters Adaptive PID Controller Design of Digital Positional Servo System In Proc. Of The First International Conference on Machine Learning and Cybernetics Beijing
- [9] Yusuf I, Bulale, Salami, Marizan S 2003 Design and Development of DSP-based hybrid Controller For Servo Driver Applications In Proceeding of 2003 IEEE Conference on Control Applications Vol 1 23-25 pp 773-778
- [10] Sugeng A, Kamarul B T, Hishamuddin J, Hussein and Bambang S 2007 Adaptive Neural Network Optimisation Control of ICE for Vehicle with Continuously Variable Transmission ICIAAS 2007: International Conference on Intelligent & Advanced Systems Vols 1-3 257-262
- [11] Hyung S H, Jeng N C, Won H L and Jin K K 1999 A Tuning for The PID Controller Utilizing Fuzzy Theory IJCNN'99 International Joint Conference on Neural Network Vol. 4 10-16 pp 2210-2215
- [12] Mohd E Z, Kamarul B T, Hussein, Bambang S, Aishah D 2010 Clamping Force Characteristic Study of Power Screw Mechanism in EMDAP 3rd International Graduate Conference on Engineering, Science and Humanities IGCESH
- [13] Bambang S, Kamarul B T, Hishamuddin J and Sugeng A 2006 Ratio Control Of An Electromechanical Dual Acting Pulley – Continuously Variable Transmission (EMDAP- CVT) System Using PD-Fuzzy Logic Control Regional Postgraduate Conference on Engineering and Science (RPCES'06) 26-27 July, Johor Bahru Malaysia