

PAPER • OPEN ACCESS

Statistical analysis on tribology behavior of stainless steel surface in aloe vera blended lubricant

To cite this article: A K Amiruddin *et al* 2020 *IOP Conf. Ser.: Mater. Sci. Eng.* **736** 052035

View the [article online](#) for updates and enhancements.

Statistical analysis on tribology behavior of stainless steel surface in aloe vera blended lubricant

A K Amirruddin^{1*}, K Kadirgama^{1,2}, D Ramasamy^{1,2}, M M Rahman¹

¹Faculty of Mechanical Engineering, University Malaysia Pahang (UMP), 26600, Pekan, Pahang, Malaysia.

²Centre of Excellence for Advanced Research in Fluid Flow (CARIFF), Universiti Malaysia Pahang, Lebuhraya Tun Razak, 26300 Gambang Kuantan, Pahang

*amirruddin@ump.edu.my

Abstract. Lubricant oil is one of the important oils that is needed for any vehicle and the additive added into the lubricant is required to boost the potential of lubricant to protect engine or any compartment that required lubrication. The presence of lubrication oil is very important in engine which is functioned to protect engine especially during combustion processes and it is needed to cool down the temperature of engine after every process. However, most of the lubricant oils are not very eco-friendly and they can have caused harm to the environment system. Several researches have been carried out recently to find new alternative additives for lubricant oil and it is safer for our environment which is now in danger. One of the alternative additives that have been widely suggested by several researchers is involving plant such as vegetables. An experiment has been carried out to justify the potential of Aloe Vera as a new additive that can replace existence chemical and synthetic additive which is harmful to the environment and costly to produce it. The conclusion of the experiments is the researcher agrees to the suitability of Aloe Vera as a new additive by using simple experiments method. Response surface method was used to design the experiments and finding the relationship between the parameters and responses. It shows that Aloe Vera additives reduce the coefficient of friction.

1. Introduction

The lubricant oil is important in internal combustion engine which functioned in reducing friction between the rubbings and bearing surface. Proper lubrication of all moving parts is essential for the Internal Combustion engine or IC Engine. Other than that, lubricant oil is important in preventing corrosion on the metal surface, to reduce expansions of metal cause by frictional heat and acts as a coolant to metal due to heat transfer media by carrying heat away from the bearings, cylinder and pistons. An important purpose of engine oil is to lubricate engine parts so that friction and wear are reduced. The lubricant technology has undergone various improvements in order to extend the life of moving parts, so it can operate under many different condition of speed, temperature, and pressure. In the internal combustion engine, loss of energy to friction between the piston ring and cylinder liner constitutes 20% to 40% of total mechanical loss and is regarded as the greatest mechanical friction loss [1]. Different engines lubrication regimes significantly affect the tribological performance of the engine [2]. Aloe Vera Nano cellulose is one of highlight for the best potential additive to lubricants



Content from this work may be used under the terms of the [Creative Commons Attribution 3.0 licence](https://creativecommons.org/licenses/by/3.0/). Any further distribution of this work must maintain attribution to the author(s) and the title of the work, journal citation and DOI.

creations. The presence of Amino acetic acid (glycine) in Aloe Vera makes it worthy as additive since Glycine and its derivatives have been used as inhibitor to prevent corrosion of metals in various environments-acidic, neutral and deuterated carbonate solution [3].

Tribology in cylinder wall, wear and corrosion of an engine wall cylinder are serious and the cylinder is the heaviest wear part of the engines. For piston skirt and the cylinder liner/wall, the friction is control by the diameter clearance, the design of the piston and the inclining action of the piston, the design of the piston skirt, the surface roughness and the pre-conditions for lubrication [14]. Strong adhesive forces between the piston rings and cylinder liner may occur under poor lubrication, causing to piston ring scuffing that comprises high friction forces and the formation of severe wear scars on the piston ring and cylinder surfaces [15]. Friction estimations by different author have been done with piston rings in combustion engines, by utilizing the drifting chamber liner or versatile bore system. In the estimation plans, the cylinder liner is permitted to move axially for the moment remove that is essential for empowering force estimations from the liner. As the relating typical constrain on a specific piston ring is known just to a specific degree, a succinct grating coefficient curve cannot have built up. The friction constrain readings are, be that as it may, exceptionally valuable, as they express the hub stacks on the rings, the frictional losses of the engines and the friction force varieties in real engines. On the other hand, for the engine tests utilizing the floating liner system, the pistons assembly friction has been contemplated by motored engines tests.

Cylinder bore polishing, which can be subdivided into light, medium and heavy polishing, is the first occurrence of wear in a cylinder liner. A light degree of bore polishing increases the oil consumption. When the bore polishing has evolved to a stage of heavy polishing, and most of the oil-retaining honing pattern has been erased, the risk of lubrication starvation and scuffing is obvious [16]. The thermal loads cause lubricant degradation by ageing and partial evaporation. The chemical loads comprise dilution by fuel, acidic combustion products and water vapor from the combustion process. The erosive loads comprise the mechanical effect of the flushing by hot gases along the upper parts of the cylinder liner surface, and the removal of oil from the liner surface. The wear of the cylinder liner is additionally accelerated by solid carbon particles from the combustion process, and possibly by dust from the intake air that can contribute by causing abrasive wear. Wear of cylinder liners occurs as well in the mid-stroke region of the piston ring motion. The wear of the cylinder liner is higher on the anti-thrust side than on the thrust side of the liner, owing to the distribution of the thrust forces during the different cycles of the engine [17].

On the piston ring and cylinder liner surfaces evidence of scuffing may be found in the shape of wear scars indicating, example plastic deformation, abrasive ploughing and the adhesive transfer of work hardened cast iron to a chromium-plated piston ring, and a "white layer" that indicates that the temperature has locally exceeded 750°C [18]. Metallurgical investigations by Shuster and co-workers on initial scuffing failures have shown the presence of minor iron-based particles on the face surfaces of Mo- and Cr-coated piston rings, and the presence of martensitic transformation on the cylinder liner surface [19]. Since the introduction of aluminium cylinders in automotive engines three decades ago, iron plating of the piston skirt has been the prime solution against piston scuffing. Recently, Wang and Tung have presented the results of a scuffing resistance study on various candidate coatings for aluminium piston skirts in aluminium cylinder liners [20].

Statistical Design and Analysis is the theoretical predictions based on experimental observations mark the essence of beneficial research. Proper use of statistical techniques significantly improves the efficiency of the experiments and allows attracting meaningful conclusions from the experimental statistics. There are two basic elements of challenge in scientific experimentation: the design of the experiment and the statistical evaluation of the data. A success experimentation calls for understanding of the important elements that affect the output. Design of experiments allows deciding the factors, which can be vital for explaining a process variation. Statistical design and analysis is processes to identify and making initial decision before and after the experiment processes. For this purposed of surface study, the DOE is chosen as the statistical design and analysis and factorial design as a method for this research.

Multiple Objective Optimizations or MOO, considers optimization issues including more than one objective function to be upgraded at the same time. MOO issues emerge in many fields, for example, engineering, financial aspects, and logistics, when ideal choices should be taken within the sight of exchange off between at least two clashing problems. For example, development of another segment may include limiting weight while amplifying quality or picking a portfolio may include augmenting the normal return while minimizes the risk. In tribology application, the MOO is suitable to use with any method such as Taguchi Method, Factorial Design and Analysis of Variance (ANOVA). The effect of the three process parameters, i.e., concentration, machine running times and traverse speed on surface roughness and coefficient of friction will be investigated. In this investigation, it wills using full factorial method is designed with three levels of parameters with the help of software Minitab version 17. It is predicted that full factorial method is a good method for optimization of various machining parameters as it reduces number of experiments.

Full Factorial Design is utilized for synchronous investigation of a few variable impacts on the procedure. By varying levels of factors simultaneously it can find optimal solution responses are measured at all combination of the experimental factor levels. The blend of the factor levels represent to the conditions at which responses will be measured. Each trial condition is a run. The reaction estimation in a perception. The whole arrangement of run is an outline of examination. It is utilized to discover the factors which are the most impact on the reaction and their cooperation between at least two components on response [33].

2. Analysis procedures

2.1. Experimental Tribo-tester Setup

Tribological behaviour test was performed to determine friction coefficient and specific wear rate between the contact surfaces using a wear tester. Figure 1 shows a schematic diagram of the wear tribo-tester for evaluating the friction coefficient for base oil and aloe vera-oil. It is simply designed sliding between movement surfaces that contact which are tool made from grey cast iron and specimen aluminium 6061. It functions mostly like piston-ring contact in engine and the tester are multi used tester which is generally work more in friction and wear experiment. The study of the tribological behaviour, the wear tester move reciprocating sliding friction was employed.

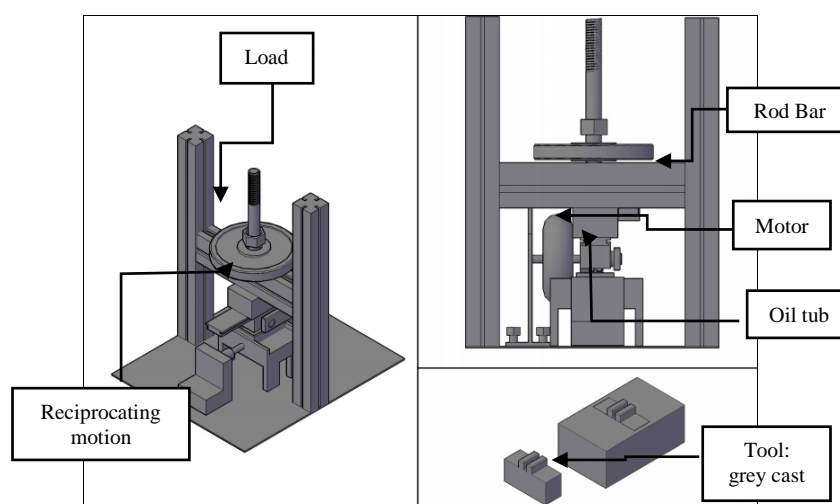

Figure 1. Schematic diagram of the wear tester for evaluating the friction coefficient for base oil and aloe vera-oil.

2.1.1. Data Acquired and Screening Processes: 20 N load

Table 1 as shown below is the data that retrieved from an experiment, which is containing several of speed. To obtain the best result, trial and error method was used to choose the suitable speed, which can give more accurate coefficient of friction.

Table 1. Variant of data for 20 N loads.

Load (in N)	Concentration (%)	Speed (rpm)
20	0	180
		200
		220
20	0.5	180
		200
		220
20	1.0	180
		200
		220

Only one speed is chosen because the suitability of Design of Experiments only allows minimum two data and one dependent (response) data only. For 20 N loads, the reasonable data that available has been shown in table 2. The data has been retrieved from an experiment of Aloe Vera as lubricant additives.

Table 2. Variation of data after trial and error process for 20 N loads.

Constant Parameter	Concentration (%)	Running time (min)
20 N, 200 RPM	0	3
		6
		9
20 N, 200 RPM	0.5	3
		6
		9
20 N, 200 RPM	1.0	3
		6
		9

2.1.2. Data Acquired and Screening Processes: 90N load

Table 3 as shown below is the data from an experiment which is containing several of speed. The speed involve in this research are 280, 300 and 320 rpm. For 90 N loads, the reasonable data that available has been shown in table 4. The data has been retrieved from an experiment of Aloe Vera as lubricant additives. From all table 4, it can be seen that the parameter for load and concentration is set to be constant but run in three different speed rpm. However, the average value will be taken as the result that is at 200 rpm and 300 rpm, respectively. This is because 200 rpm and 300 rpm are the speed chooses based on top dead centres concept in combustion engine, even though the test was run for less 20 rpm and more 20 rpm from that desired rpm point value.

Table 3. Variant of data for 90 N loads.

Load (in N)	Concentration (%)	Speed (rpm)
90 N	0	280
		300
		320
90 N	0.5	280
		300
		320
90N	1.0	280
		300
		320

Table 4. Variation of data after trial and error process for 90 N loads.

Constant Parameter	Concentration (%)	Running time (min)
90 N, 300 rpm	0	3
		6
		9
90 N, 300 rpm	0.5	3
		6
		9
90 N, 300 rpm	1.0	3
		6
		9

2.1.3. 20 N load statistical analysis: design of experiment (DOE). The statistical analysis processes are began by choosing the suitable layout of MINITAB that suit with the experiments requirements. Thus, I choose Full Factorial Design as suitable analysis method for my research and reason why I choose that statistical design is due to limit of data that has been retrieved from experiments. Below are examples step of processes of statistical analysis for this research for load of 20 N. DOE is a controlled and systematic method for collection and analysis large amount of data in order to obtain a comprehensive assessment of the factors under investigation [36]. Full Factorial Design (FFD) was used to perform friction test on the tribological behaviour of Aloe Vera oil as bio-lubricant. A FFD is a 3-level factorial design devoid of any embedded factorial and subset of the factorial combinations from 2k factorial design. The design comprises data from 9 experiments (same concentration and constant parameter but different running times) that are used to construct a model equation for the coefficient of friction of Aloe Vera as lubricant oil additives. The statistical significance level (P-value) was set at 0.05. The Coefficient of Friction was acts as dependent responses. The DOE for this statistical analysis research was constructed using Full Factorial Design to obtain the optimization for different parameter in the tribological behaviour using MINITAB software, a statistical analysis and design platform.

2.1.4. Full Factorial Design (FFD). A full factorial plan characterizes a trial where trials are keeping running at all conceivable mixes of component settings. A full factorial plan permits the estimation of

every single conceivable association. Full factorial plans are substantial contrasted with screening outlines, and since abnormal state collaborations are regularly not dynamic, they can be wasteful. They are ordinarily utilized when you have few elements and levels and need data about every single conceivable communication [34].

In a FFD, you carry out an experimental run at every combination of the factor level. The sample size is made from the numbers of levels of the elements. As an example, a factorial experiment with a two-level factor, a three-level factor, and a 4-degree element has $2 \times 3 \times 4 = 24$ runs. The FFD platform supports both continuous elements and categorical elements with arbitrary numbers of ranges. Its miles assumed that you could run the rigors in a very random fashion.

FFD are the maximum conservative of all layout types. However, due to the fact the sample length grows exponentially with the number of factor, FFD are frequently too pricey to run. Custom designs, definitive screening designs, and screening designs are less conservative but extra efficient and cost-powerful. In order to study the effects of the tribological parameters, the most important tribological criteria which coefficient of friction (COF) act as the response. Table 5 shows the suitable levels of the factors used to design the parameters for a tribological experiment for 20 N.

Table 5. The suitable levels of the factors used to design the parameters for a tribological experiment for 90 N.

Parameter	-1 (Low)	0 (Standard)	+1 (High)
Volume Concentration (%)	0	0.5	1.0
Times (min)	3	6	9
Speed (rpm)	180	200	220
Parameter	-1 (Low)	0 (Standard)	+1 (High)
Volume Concentration (%)	0	0.5	1.0
Times (min)	3	6	9
Speed (rpm)	280	300	320

2.1.5. Mathematical modelling and equation in FFD. The modelling in this research is performed by regression analysis through FFD. In the present research, FFD is utilized to establish the relationship between the two tribology parameter and two responses COF and Surface Roughness. The experimental values were analysed and mathematical models were developed that illustrated the relationship between the process parameters and responses. The coefficients of the models were estimated by statistical analysis from the experimental results. Overall $3^2 = 9$ COF experiments are carried out.

2.2. First order model

The simplest model which can be used in FFD is based on a linear function. For its application is necessary that the responses obtained are well fitted to the following equation:

$$Y = \beta_0 + \sum_{i=1}^n \beta_i \chi_i + \epsilon \quad (1)$$

Where n is the number of variables, C is the constant term, m represents the coefficients of the linear parameters, x_i represents the variables and ε is the residual associated to the experiments. The proposed linear model correlating the responses and independent variables can be representing by the following expressions derived from equation (1):

$$y = m\text{Concentration} + n\text{Times} + C \quad (2)$$

Where y is response, C , m and n are the constants. MINITAB 17 Software was used to generate the response surface plot and factorial plot, and the optimization of the factors to investigate COF.

2.3. Second Order Model

In linear model, the responses should not present any curvature [35]. To evaluate curvature, a second-order model must be used. Three level factorial designs are used in the estimation of first order effects, but they failed when additional effects, such as second-order effects are significant. So a central point in three-level factorial designs cannot be used to evaluating curvature. The next level of the polynomial model should contain additional terms, which describe the interaction between the different experimental variables. A second order-polynomial response empirical model can develop as follows to evaluate the parametric effects on the various tribological criteria:

$$f(x) = \beta_0 + \sum_{i=1}^n \beta_i x_i + \sum_{i=1}^n \beta_{ii} x_i^2 + \sum_{i=1}^n \beta_{ij} x_i x_j + \varepsilon \quad (3)$$

Where $f(x)$ is the response, which is COF. It was created by various process variables of tribological parameters. β_0 , β_i , β_{ii} , and β_{ij} are the regression coefficients for intercept, linear, quadratic, and interaction terms, respectively. X_i and X_j are the independent variables. Contour plots were obtained using the fitted model by keeping the least dynamic independent variable at a constant value while changing the other two variables [36].

3. Result and discussion

3.1. Empirical Model and Regression Analysis on First Order Model: 20 N Load

Below are result and discussion of statistical analysis of Aloe Vera concentration as additive for lubricant oil.

Table 6. Statistical Analysis design and results.

Experiment	Concentration (%)	Times(min)	FITS 1 (1 st Order COF)
1	0.0	6	0.422567
2	0.0	9	0.437200
3	1.0	6	0.364933
4	1.0	3	0.363400
5	1.0	9	0.379567
6	0.0	3	0.421033
7	0.5	9	0.392333
8	0.5	6	0.377700
9	0.5	3	0.376167

Table 6 represents the results of experiments conducted to investigate the tribological properties of Aloe Vera as lubricant oil additives while figure 2 shows the residual plot for the COF of as a function of the independent variable. From the normal distribution of the data along the line in the normal probability plot from figure 2, it can assumed that the residuals of the models of the COF for of Aloe Vera concentration as lubricant oil additives are normally distributed.

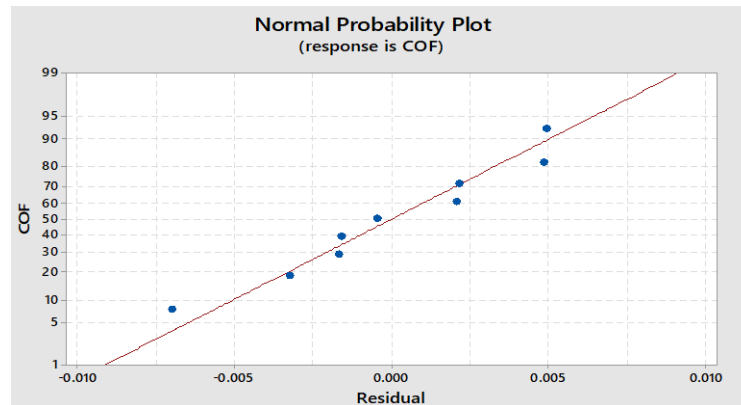

Figure 2. Residual plots of 20 N data obtained for COF.

Table 7 represent the analysis of variance (ANOVA) for COF. From table 7, the fit summary recommends that the empirical model is statistically significant for the analysis of COF. The value of R^2 was more than 95 % which means that the empirical model provides an excellent explanation of the relationship between the independent variables (factors) and the response (COF). Based on table 7 below, the associated P-value for the model was lowers than 0.05 (95% confidence interval). This indicates that the model was considered statically significant. This implies that the model could fit, and it is adequate [38].

Table 7. Analysis of Variance for first order for COF.

Source	DF	Adj SS	Adj MS	F-Value	P-Value
Model	4	0.005975	0.001494	49.06	0.001
Linear	4	0.005975	0.001494	49.06	0.001
Concentration	2	0.005498	0.002749	90.28	0.000
Time	2	0.000478	0.000239	7.85	0.041
Error	4	0.000122	0.000030		
Total	8	0.006097			

$$S = 0.0055178 \quad R\text{-Sq} = 98.00\% \quad R\text{-Sq (pred)} = 89.89\% \quad R\text{-Sq (adj)} = 96.01\%$$

From Table 8, the table 8 below are the analysis of coefficient and effect of concentration and times to the COF. As you can see in Table 8, only 0% and 0.5 % concentration and times of 3 min and 6 min, give value to the analysis where 1.0 % does not appears in first order of COF. It can be explained as if P-value is less than 0.05; it means the model is significant at 95% confidence level. Furthermore, the significance of each coefficient in the full model was examined by the T-values and P-values and the results are listed in table 8. The larger values of T-value and smaller values of P-value indicate that the corresponding coefficient is highly significant [37].

Table 8. Analysis of Coefficient for first order for COF.

Term	Coef.	SE Coef	T-Value	P-Value	VIF
Constant	0.39277	0.00184	213.54	0.000	0.00
Concentration					
0.0	0.03417	0.00260	13.14	0.000	1.33
0.5	-0.01070	0.00260	-4.11	0.015	1.33
Time					
3	-0.00590	0.00260	-2.27	0.086	1.33
6	-0.00437	0.00260	-1.68	0.169	1.33

To calculate the parameter of Concentration, C and Time, T, the least square method was used with the aid of MINITAB. The first-order linear equation used to predict the COF was expressed as equation 4 (Regression Analysis Equation for 1st order) and 5 (Derivation of Regression Analysis 1st order). According to the equation, it can easily notice that the COF is affected significantly by Concentration while Time are not significant due to the P-value is greater than 0.05. The regression analyses below are the equation based analysis for this simulation where the Equation 5 are derivation of regression analysis.

$$\text{COF} = 0.39277 + 0.03417 \text{ Concentration}_{0.0} - 0.01070 \text{ Concentration}_{0.5} - 0.02347 \text{ Concentration}_{1.0} + 0.00590 \text{ Time}_{3} - 0.00437 \text{ Time}_{6} + 0.01027 \text{ Time}_{9} \quad (4)$$

$$\text{COF} = 0.39277 + 0.03417 C_{0.0} - 0.01070 C_{0.5} - 0.02347 C_{1.0} - 0.00590 T_{3} - 0.00437 T_{6} + 0.01027 T_{9} \quad (5)$$

3.2. Empirical Model and Regression Analysis on Second Order Model: 20N Load

For table 9, this is the data that has been analysing by using MINITAB 17. The responses for this second order model are FITS 2.

Table 9. Statistical analysis design and results.

Experiment	Concentration (%)	Times (min)	FITS 2 (2nd Order of COF)
1	0.0	6	0.4275
2	0.0	9	0.4302
3	1.0	6	0.3617
4	1.0	3	0.3618
5	1.0	9	0.3844
6	0.0	3	0.4231
7	0.5	9	0.3945
8	0.5	6	0.3760
9	0.5	3	0.3757

However, for second orders there are no value of P-Value has stated in Table 10 and 9, and the R-sq is 100%, which is invalid for the statistical analysis. To prove for this 2nd order is relevant or not, the existence of P-value which is less than 0.05 are required so the 95% confident interval can be

determined either significant or not [37]. However, the value is unavailable so the second order model is invalid for this research.

Table 10. Analysis of variance of friction.

Source	DF	Adj SS	Adj MS	F-Value	P-Value
Model	8	0.006097	0.001494	*	*
Quadratic	4	0.005975	0.001494	*	*
Concentration	2	0.005498	0.002749	*	*
Time	2	0.000478	0.000239	*	*
2-Way Interactions	4	0.000122	0.000030	*	*
Concentration*Times	4	0.000122	0.000030	*	*
Error	0	*	*		
Total	8	0.006097			

S=* R-sq=100% R-sq(adj)= *% R-sq(pred)=*%

As you can see in table 11, the error is stated as 0 which is not meet requirement of statistical analysis where the error is must be greater than zero and the P-value is not available so it cannot determine either the 95% of confidence interval can be achieve or not. The goodness of fit of the mathematical models was also tested by coefficient of determination (R-sq) and adjusted coefficient of determination (R-sq adj). The R-sq is the proportion of the variation in the dependent variable explained by the regression model. On the other hand, R-sq (adj) is the coefficient of determination adjusted for the number of independent variables in the regression model. Unlike R-sq, the R-sq adj may decrease if the variables are entered in the model that does not add significantly to the model fit. The R-sq and R-sq adj values of mathematical models are found (*) and (*) respectively which clearly indicate the excellent correlation between the experimental and the predicted values of the responses are not be achieved [37].

Table 11. Estimate regression coefficient.

Term	Coef.	SE Coef	T-Value	P-Value	VIF
Constant	0.3928	*	*	*	0.00
Concentration					
0.0	0.03417	*	*	*	1.33
0.5	-0.01070	*	*	*	1.33
Time					
3	-0.005900	*	*	*	1.33
6	-0.004367	*	*	*	1.33
Concentration*Times					
0.0*3	0.002067	*	*	*	1.78
0.0*6	0.004933	*	*	*	1.78
0.5*3	-0.000467	*	*	*	1.78
0.5*6	-0.001700	*	*	*	1.78

The first-order linear equation used to predict the COF was expressed as the regression equation, the influence of Concentration x Times makes the data not significant and some of data become invalid. Equation 6 represents regression analysis equation for 2nd order:

$$\begin{aligned} \text{COF} = & 0.3928 + 0.03417 \text{ Concentration}_{0.0} - 0.01070 \text{ Concentration}_{0.5} \\ & - 0.02347 \text{ Concentration}_{1.0} - 0.005900 \text{ Time}_3 - 0.004367 \text{ Time}_6 + 0.01027 \text{ Time}_9 \\ & + 0.002067 \text{ Concentration*Time}_{0.0\ 3} + 0.004933 \text{ Concentration*Time}_{0.0\ 6} \\ & - 0.007000 \text{ Concentration*Time}_{0.0\ 9} - 0.000467 \text{ Concentration*Time}_{0.5\ 3} \\ & - 0.001700 \text{ Concentration*Time}_{0.5\ 6} + 0.002167 \text{ Concentration*Time}_{0.5\ 9} \\ & - 0.001600 \text{ Concentration*Time}_{1.0\ 3} - 0.003233 \text{ Concentration*Time}_{1.0\ 6} \\ & + 0.004833 \text{ Concentration*Time}_{1.0\ 9} \end{aligned} \quad (6)$$

Meanwhile, Equation 7 represents derivation of regression analysis for 2nd order:

$$\begin{aligned} \text{COF} = & 0.3928 + 0.3417 C_{0.0} - 0.01070 C_{0.5} - 0.02347 C_{1.0} - 0.005900 T_3 - 0.004367 T_6 + \\ & 0.01027 T_9 + 0.002067 C*T_{0.0*3} + 0.004933 C*T_{0.0*6} - 0.007000 C*T_{0.0*9} - 0.000467 \\ & C*T_{0.5*3} - 0.001700 C*T_{0.5*6} + 0.002167 C*T_{0.5*9} - 0.001600 C*T_{1.0*3} - 0.003233 \\ & C*T_{1.0*6} + 0.004833 C*T_{1.0*9} \end{aligned} \quad (7)$$

Hence, the results given in table 12 suggest that the influence of Concentration × Times (C × T), make the second order non-significant and therefore can be removed from the full model to further improve the model or to make it valid.

3.3. Empirical model and regression analysis on first order model: 90 N Load

Below are result and discussion of simulation of Aloe Vera concentration as additive for lubricant oil. The same method is repeated for 90 N.

Table 12. Statistical analysis design and results.

Experiment	Concentration (%)	Times (min)	FITS 1 (1st Order COF)
1	1.0	3	0.0736667
2	0.5	9	0.0840667
3	1.0	9	0.0728667
4	0.0	3	0.0957667
5	0.5	3	0.0848667
6	1.0	6	0.0726667
7	0.5	6	0.0838667
8	0.0	6	0.0947667
9	0.0	9	0.0949667

Table 12 represents the results of experiments conducted to investigate the tribological properties of Aloe Vera as lubricant oil additives while figure 3 shows the residual plot for the coefficient of friction of as a function of the independent variable. From the normal distribution of the data along the line in the normal probability plot from figure 3, it can assumed that the residuals of the models of the coefficient of friction for Aloe Vera as lubricant oil additives are normally distributed.

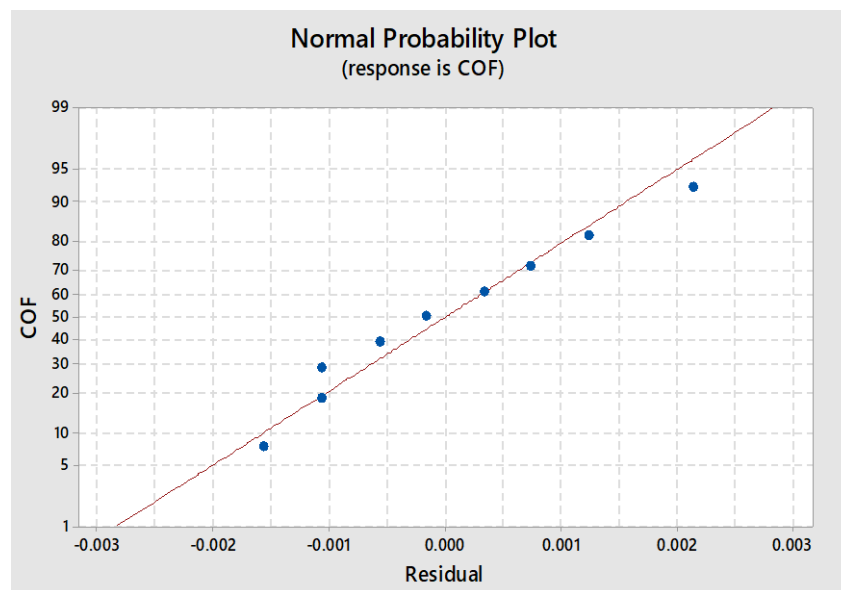

Figure 3. Residual plots of 90 N data obtained for coefficient of friction.

Table 13 represent the analysis of variance (ANOVA) for coefficient of friction. From table 13, the fit summary recommends that the empirical model is statistically significant for the analysis of COF. The value of R-sq was more than 95% which means that the empirical model provides an excellent explanation of the relationship between the independent variables (factors) and the response (COF). Based on table 13 below, it can be appreciated that the P-value is less than 0.05 which means that the model is significant at 95% confidence level [42]. This indicates that the model was considered statically significant. This implies that the model could fit, and it is adequate [38].

Table 13. Analysis of variance for first order for COF.

Source	DF	Adj SS	Adj MS	F-Value	P-Value
Model	4	0.000734	0.000184	62.23	0.001
Linear	4	0.000734	0.000184	62.23	0.001
Concentration	2	0.000733	0.000366	124.18	0.000
Time	2	0.000002	0.000001	0.28	0.766
Error	4	0.000012	0.000003		
Total	8	0.000746			

S =0.0017176 R-sq = 98.42% R-sq (adj) =96.84% R-sq (pred) = 91.99%

The significance of each coefficient in the full model was examined by the T-values and P-values and the results are listed in table 14. The larger values of T-value and smaller values of P-value indicate that the corresponding coefficient is highly significant [37].

Table 14. Estimate regression coefficient.

Term	Coefficient.	SE Coef	T-Value	P-Value	VIF
Constant	0.084167	0.000573	147.01	0.000	
Concentration					
0.0	0.011000	0.000810	13.59	0.000	1.33
0.5	0.000100	0.000810	0.12	0.908	1.33
Time					
3	0.000600	0.000810	0.74	0.500	1.33
6	-0.000400	0.000810	-0.49	0.647	1.33

To calculate the parameter of Concentration, C and Time, T, the least square method was used with the aid of MINITAB 17. The first-order linear equation used to predict the coefficient of friction was expressed as equation 6. According to the equation and table 14, it can easily notice that the coefficient of friction is affected significantly by Concentration while Time are not significant due to the P-value is greater than 0.05. The regression analyses below are the equation based analysis for this statistical analysis where the Equation 9 are derivation of regression analysis. Equation 8 shows regression analysis equation for 1st order:

$$\text{COF} = 0.084167 + 0.011000 \text{ Concentration}_{0.0} + 0.000100 \text{ Concentration}_{0.5} - 0.011100 \text{ Concentration}_{1.0} + 0.000600 \text{ Time}_{3} - 0.000400 \text{ Time}_{6} - 0.000200 \text{ Time}_{9} \quad (8)$$

Equation 9 shows derivation of regression analysis equation 1st order:

$$\text{COF} = 0.084267 + 0.011000 C_{0.0} + 0.000100 C_{0.5} - 0.011100 C_{1.0} + 0.000600 T_{3} - 0.000400 T_{6} - 0.000200 T_{9} \quad (9)$$

3.4. Empirical Model and Regression Analysis on Second Order Model: 90 N load

For table 15, this is the data that has been analysing by using MINITAB 17. The responses for this second order model are FITS 2.

Table 15. Statistical analysis design and results.

Experiment	Concentration (%)	Times (min)	FITS 2 (2nd Order COF)
1	1.0	3	0.0726
2	0.5	9	0.0853
3	1.0	9	0.0732
4	0.0	3	0.0979
5	0.5	3	0.0838
6	1.0	6	0.0734
7	0.5	6	0.0837
8	0.0	6	0.0942
9	0.0	9	0.0934

S = *% R-sq = 100% R-sq (adj) = * R-sq (pred) = *

For second orders there is no valid value for P-Value has stated and the R-sq is 100% which is invalid for the statistical analysis. It can be explained as the P-value is needed, so 2nd order model can be determining either significant or not. So again, the second order models are invalid for full factorial design.

Table 16. Analysis of variance for 90 N.

Source	DF	Adj SS	Adj MS	F-Value	P-Value
Model	8	0.000746	0.000093	*	*
Linear	4	0.000734	0.000184	*	*
Concentration	2	0.000733	0.000366	*	*
Time	2	0.000002	0.000001	*	*
2-Way Interactions	4	0.000012	0.000003	*	*
Concentration*Times	4	0.000012	0.000003	*	*
Error	0	*	*		
Total	8	0.000746			

S = * R-sq = 100% R-sq(adj) = * R-sq(pred) = *

The goodness of fit of the mathematical models was also tested by coefficient of determination (R-sq) and adjusted coefficient of determination (R-sq adj). The R-sq is the proportion of the variation in the dependent variable explained by the regression model. On the other hand, R-sq (adj) is the coefficient of determination adjusted for the number of independent variables in the regression model. The R-sq and R-sq adj values of mathematical models are found (*/invalid) respectively which clearly indicate the excellent correlation between the experimental and the predicted values of the responses cannot be achieved [37].

Table 17. Estimate regression coefficient.

Term	Coef.	SE Coef	T-Value	P-Value	VIF
Constant	0.08417	*	*	*	0.00
Concentration					
0.0	0.01100	*	*	*	1.33
0.5	0.000100	*	*	*	1.33
Time					
3	0.000600	*	*	*	1.33
6	-0.004000	*	*	*	1.33
Concentration*Times					
0.0*3	0.002133	*	*	*	1.78
0.0*6	-0.000567	*	*	*	1.78
0.5*3	-0.001067	*	*	*	1.78
0.5*6	-0.001067	*	*	*	1.78

The first-order linear equation which used to predict the coefficient of friction was expressed as the regression equation below, and from the equation we can assume that the influence of Concentration x Times make the data are not significant. The following equation 10 shows regression analysis equation for 2nd order:

$$\begin{aligned} \text{COF} = & 0.08417 + 0.01100 \text{ Concentration}_{0.0} + 0.000100 \text{ Concentration}_{0.5} \\ & - 0.01110 \text{ Concentration}_{1.0} + 0.000600 \text{ Time}_{3} - 0.000400 \text{ Time}_{6} - 0.000200 \text{ Time}_{9} \\ & + 0.002133 \text{ Concentration*Time}_{0.0\ 3} - 0.000567 \text{ Concentration*Time}_{0.0\ 6} \\ & - 0.001567 \text{ Concentration*Time}_{0.0\ 9} - 0.001067 \text{ Concentration*Time}_{0.5\ 3} \end{aligned}$$

$$- 0.000167 \text{ Concentration} * \text{Time}_{0.5} + 0.001233 \text{ Concentration} * \text{Time}_{0.5} \quad (10)$$

3.5. Factor Versus Response (COF)

3.5.1. Factor (Concentration and Times) against COF. As shown in figure 4, the overall discussion that can obtain from the statistical analysis for both 20 N (1st and 2nd order) is the increasing of concentration value cause the value of COF decreased gradually while the increasing of times causes the value of COF increase. The same pattern has been record by 90 N (1st and 2nd order), where the concentration causes the COF decreased sharply but the increasing of time causes the value of COF decreased then increased a bit. It agrees that time and concentrations affect the value of coefficient of friction.

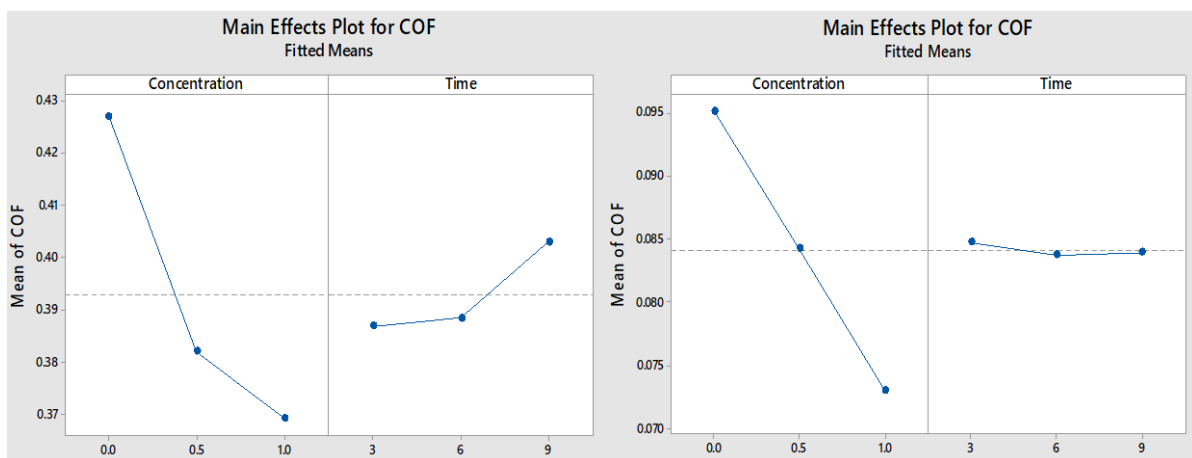

Figure 4. Mean effect plot concentration and times against response for 20 N and 90 N respectively for 1st order and 2nd order model.

3.5.2. Factor (Concentration and RPM) against COF. In figure 5 below, the overall discussion that can obtain from the statistical analysis for both 20 N is the increasing of concentration value cause the value of COF decreased gradually while the increasing of times causes the value of COF increase. The same pattern has been record by 90 N, where the concentration causes the COF decreased and the increasing of time causes the value of COF decreased gradually.

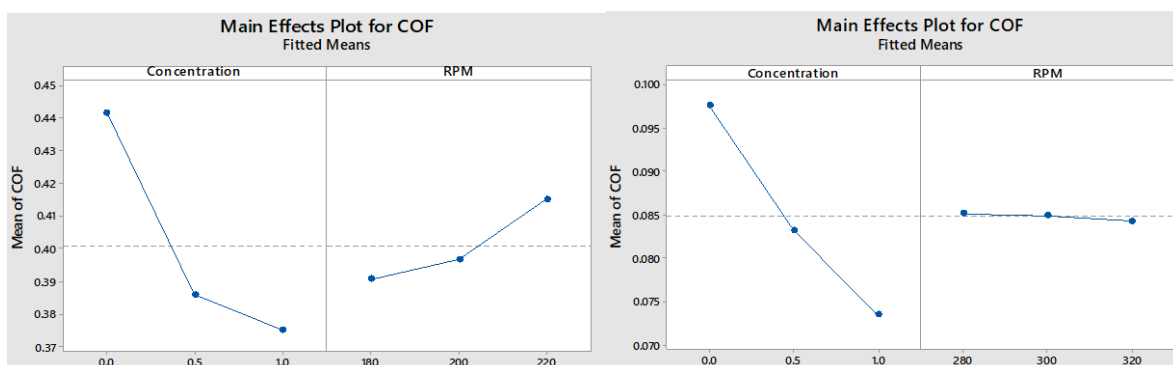

Figure 5. Mean effect plot concentration and RPM against response for 20N and 90 N for 1st and 2nd order model.

3.5.3. Factor (Concentration and Times) against COF. Figure 6 is utilized to demonstrate the correlation between the residuals and from this, it is underscored that an inclination to have keeps running of positive and negative residuals shows the presence of a specific correlation. Likewise, the plot demonstrates that the residuals are dispersed equitably in both positive and negative along the run. Subsequently the information can be said to be autonomous [37].

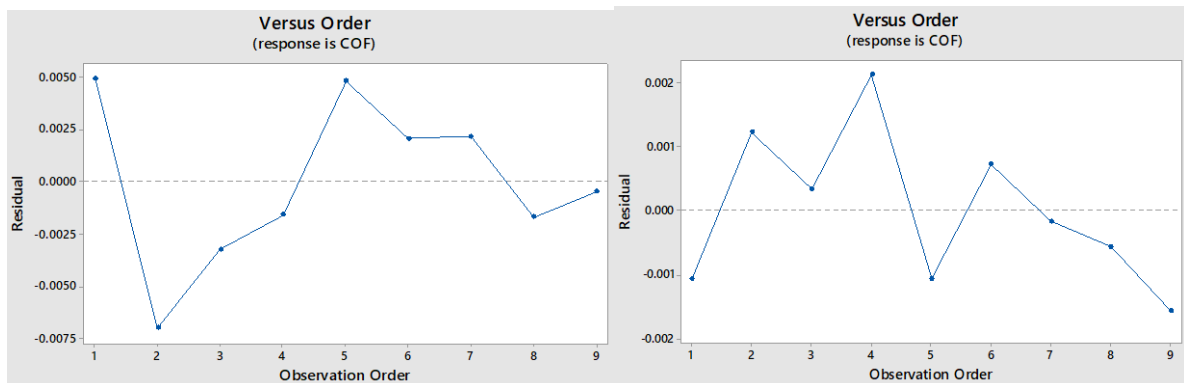

Figure 6. Correlation between concentration and times residual of 20 N and 90 N for 1st order.

3.5.4. Factor (Concentration and RPM) against COF

Figure 7 is utilized to demonstrate the correlation between the residuals and from this, it is underscored that an inclination to have keeps running of positive and negative residuals shows the presence of a specific correlation. Likewise, the plot demonstrates that the residuals are dispersed equitably in both positive and negative along the run. Subsequently the information can be said to be autonomous [37].

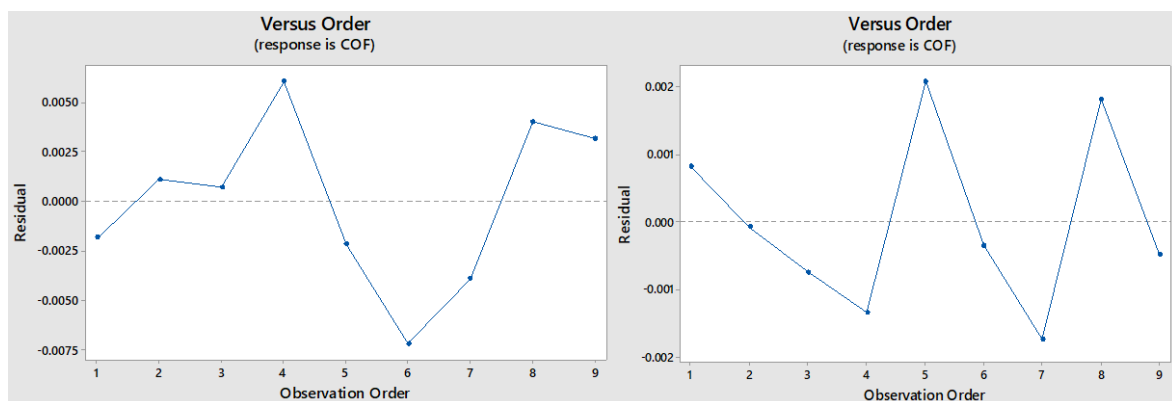

Figure 7. Correlation between Concentration and RPM residual of 20 N and 90 N for 1st order.

4. Conclusion

As conclusions, the study examined the effects of various control parameters namely speed, load, and volume composition on the responses of coefficient of friction and wear rate. The following conclusion can be derived based on the results obtained. From the research, there are several conclusions can be make;

1. The relationship of coefficient of friction with Aloe Vera concentration, load, speed (RPM) and Times has been effectively gotten by utilizing FFD at 95% confidence interval.
2. According to the concentration versus time result, the friction coefficient between the three concentrations of oil shows a considerable difference.
3. It does show that by using Aloe Vera concentration as a lubricant additive, it gives small impact on the Stainless-steel surface regarding on the coefficient of friction.
4. The data accumulated near the best fit lines in 1st order model shows that the result are significant and can be accepted as suitability of Aloe Vera as additive.
5. For second order, the data are negligible due to the invalid data that has been recorded and we can assume that, the FFD is unsuitable for second order.

So, the experimental conclusion which stated that the Aloe Vera can be used as additive is acceptable.

5. Acknowledgments

The authors would like to acknowledge University Malaysia Pahang (UMP) (www.ump.edu.my) and Ministry of Higher Education (MOHE) of Malaysia in FRGS/1/2018/TK03/UMP/02/26 RDU Grants RDU190194 and RDU180328 which made this study possible.

6. References

- [1] Çakir M and Akçay I H 2011 *Journal of Technical Sciences, E –Publishing* **16**
- [2] Cesur I, Ayhan V, Parlak A, Sava O and Aydin Z 2015 *Adv. Mech. Eng.* **6** 503212–503212
- [3] Raja A S, Rajendran S, Sathiyabama J and Angel P 2014 *International Journal of Innovative Research in Science, Engineering and Technology* **3** 11455
- [4] Singh R K and Kumar V 2014 *Global Journal of Science Frontier Research: B Chemistr* **14**
- [5] Mobarak H M 2014 *Renewable and Sustainable Energy Reviews* **33** 34–43
- [6] Winsberg E 2015 *Stanford Encycl. Philos.* 1–20.
- [7] Stachowiak G W and Batchelor A W 2006 *Eng. Tribol.* 705–717
- [8] Liew W and Hsien Y, 2015 *Utilization of Vegetable Oil as Bio-lubricant and Additive in Towards Green Lubrication in Machining* 7–17.
- [9] Zhu G 1993 *Tribology Series* **26** 183-211
- [10] Achaw O-W 2012 *A Study of the Porosity of Activated Carbons Using the Scanning Electron Microscope* IntechOpen.
- [11] Arthur R, Christoph B and Shah R 2019 *Lubricants* **7** 8
- [12] Kapoor A, Tung S C, Schawartz S E, Priest M, and Dwyer-Joyce R S 2001 *Mod. Tribol. Handb.*
- [13] Bedajangam S K and Jadhav N P 2013 *Int. J. Sci. Res. Publ.* **3** 2250–3153
- [14] Andersson P, Tamminen J and Sandström C E 2002 *Tied. - Valt. Tek. Tutkimusk.* **2178** 3–105
- [15] Demas N G, Erck R A, Ajayi O O and Fenske G R 2012 *Lubr. Sci.* **24** 216–227
- [16] Dong J, Van De Voort. R F, Ismail A A, Akochi-Koble E and Pinchuk D 2000 *Lubr.Eng.* **56** 12–20
- [17] Dong W P, Davis E J, Butler D L and Stout K J 1995 *Tribol. Int.* **28** 453–463
- [18] Lacey P I and Stockwell R T 1999 *Tribol. Trans.* **42** 192–201
- [19] Shuster M, Mahler F and Crysler D 1999 *Tribol. Trans.* **42** 116–125
- [20] Wang Y and Tung S C 1999 *Wear* **225–229** 1100–1108
- [21] Tung S C and McMillan M L 2004 *Tribology International* **37** 517–536
- [22] Udonne J D and Onwuma H O 2015 *Chem. Eng.* **6** 10–21

- [23] Klemm D, Heublein B, Fink H P and Bohn A 2005 *Angewandte Chemie - International Edition* **44** 3358–3393
- [24] Habibi Y, Lucia L A and Rojas O J 2010 *Chem. Rev.* **110** 3479–3500
- [25] Xu P, Donaldson L A, Gergely Z R and Staehelin L A 2007 *Wood Sci. Technol.* **41** 101–116
- [26] Krässig H A 1995 *Carbohydr. Polym.* **26** 313–314
- [27] Meyer K and Lotmar W 1936 *Helv. Chim. Acta* **19** 68–86
- [28] Jim B, Pepke E, Jeff H, Kathryn F and Harry G 2016 *Nanotechnology and the Forest Products Industry: Commercial Opportunities* Dovetail Partners Report
- [29] Cheng S, Panthapulakkal S, Sain M and Asiri A 2014 *J. Appl. Polym. Sci.* **131** 40039
- [30] Sharrif M M and Kumar V S 2011 *Int J Biol Med*, vol. **2** 466–471
- [31] Klein A D and Penneys N S 1988 *J. Am. Acad. Dermatol.* **18** 714–720
- [32] Cheng S, Panthapulakkal S, Ramezani N, Asiri A M and Sain M 2014 *BioResources* **9** 7653–7665
- [33] Patel G and Raiyani H 2016 *Int. J. Mechatronics and Manufacturing Systems* **1** 275–282
- [34] Peng Chang B, Md Akil H, Nasir R and Khan A 2015 *Tribol. Int.* **88** 252–262
- [35] Bezerra M A, Santelli R E, Oliveira E P, Villar L S and Escalera L A 2008 *Talanta.* **76** 965–977
- [36] Rajasekhar P, Ganesan G and Senthilkumar C 2014 *Procedia Engineering* **97** 2099–2109
- [37] Mishra P 2012 *Int. J. Appl. Res. Mech. Eng.* **2** 7–11